



AURORA
WATER

City of Aurora

Rules and Regulations

Regarding Stormwater
Discharges Associated with
Construction Activities



City of Aurora

Rules and Regulations Regarding Stormwater Discharges Associated with Construction Activities

Adopted August 1, 2009

Amended November 17, 2010 Effective November 26, 2010

THIS PAGE IS INTENTIONALLY BLANK

Acknowledgements

The City of Aurora acknowledges and thanks the following individuals and organizations for their contributions to this manual.

Aurora Water

Nicole K. Johnston, P.E.

Deborah Kula, P.E.

Sean Lieske

Clifford Stephens, P.E.

David Douglas

Aurora Public Works

Charlie Cooper

Jon Crews

Sean Burke

Aurora Parks, Recreation and Open Space Department

Douglas Hintzman

Previous City of Aurora Employees

Joe Wingert, P.E.

Janel Servis

Tom Gore

Brian Laschanzky

Douglas County

Erik Nelson, Project Engineer,

Principal GESC Author

This manual relies significantly on previous work by others in several existing storm drainage manuals including:

Urban Storm Drainage Criteria Manual, Volume 3 (UDFCD 1999, 2008)

CONSTRUCTION ACTIVITIES STORMWATER MANAGEMENT PLANS AN INFORMATION GUIDE (Wastewater Management Division Department of Public Works City and County of Denver, 2006)

Douglas County Grading, Erosion and Sediment Control (GESC) Manual (Douglas County Department of Public Works, Engineering Division, 2004)

STORMWATER DISCHARGES ASSOCIATED WITH CONSTRUCTION ACTIVITY GENERAL PERMIT APPLICATION and STORMWATER MANAGEMENT PLAN PREPARATION GUIDANCE CDPS General Permit – Stormwater Discharges Associated with Construction Activity (Colorado Department of Public Health and Environment Water Quality Control Division – Stormwater Program, 2007)

Stormwater Pollution Prevention Plan Template (Environmental Protection Agency – 2007)

In addition, the City would like to thank all internal and external stakeholders who provided reviews of various drafts of the Manual.

THIS PAGE IS INTENTIONALLY BLANK

Table of Contents

City of Aurora	i
Acknowledgements	iii
Table of Contents	v
Introduction	1
I. 1 Purpose of Document.....	1
I. 2 To whom does the City of Aurora Stormwater Quality Permit/Construction Activities pertain?.....	2
I. 3 Relationship of the City of Aurora Stormwater Quality Permit/Construction Activities process to other City criteria and processes	2
I. 4 Why does the City regulate stormwater discharges from construction sites in Aurora?	2
I. 5 What Is The Relationship Between Federal, State, and Local Stormwater Permitting.....	3
I.5.1 EPA SWPPP Guidance Document Excerpt	3
I.5.2 The State of Colorado Public Health Department – Water Quality Control Division.....	3
I. 6 Variances & Appeals	4
I. 7 Grandfathering	4
I. 8 Definition of Terms.....	5
Chapter 1: Stormwater Quality Discharge Permit Basics for Construction Activities within City of Aurora	11
1. 1 What Projects Require a City of Aurora Stormwater Quality Discharge Permit for Construction Activities?	11
1.1.1 Residential Development	11
1.1.2 Commercial Development.....	12
1.1.3 Utility Construction	12
1.1.4 City-Owned Projects.....	13
1.1.5 Temporary Batch Plants	13
1.1.6 Cut and Fill Sites	13
1.1.7 Mining Sites	13
1.1.8 Projects exempted from City of Aurora Stormwater Quality Permit/Construction Activities.....	14
1. 2 Who Obtains the Permit?	15
1.2.1 Master Developers	15
1.2.2 Builders.....	15
1.2.3 City.....	15
1.2.4 Utility Builder.....	15
1.2.5 Operator of a Temporary Batch Plant	16
1. 3 What Type of Permit is Required?	16
1.3.1 Local	16
1.3.2 Other Permits and Requirements Apply	16
1.4 How Does One Obtain a City of Aurora Stormwater Quality Discharge Permit for Construction Activities?	17
1.4.1 How to Obtain a Permit.....	17
Chapter 2: Design Phase Requirements	22
2.1 Design Phase Overview	22
2.2 Design of System of Construction Stormwater BMPs and Preparation of Stormwater Management Plan (SWMP).....	22

2.2.1 Standard COA SWMP Narrative Report Requirements.....	23
2.2.2. General SWMP Design and Drawing Requirements	43
2.2.3 Variances	57
2.2.4 Appeals.....	57
2.3 Permanent BMPs	58
Chapter 3: Construction Phase Requirements	60
3.1 Pre-Construction: SWMP Administrator Designation and Training	60
3.1.1 Qualifications of SWMP Administrators (and alternates).....	60
3.1.2 Staff Training on SWMP	61
3.1.3 Current Construction Phase Compliance Assistance Available to Permittees and Others by City of Aurora/Aurora Water and Others.....	61
3.1.4 General Construction Erosion Control Requirements Set Forth by COA	62
3.2 Erosion Control Kick-Off Meeting, Initial Plan Amendments Initial Site Inspection, Construction .	63
3.2.1 Erosion Control Kick-Off Meeting.....	63
3.2.2 Initial Plan Amendment.....	63
3.2.3 Initial Inspection and Permit Execution	64
3.3 Construction	65
3.3.1 On-Site Documentation.....	65
3.3.2. BMP Maintenance and Inspection.....	66
3.3.3 Management of the SWMP.....	66
3.3.4 Special Development Requirements.....	68
3.3.5 Re-assigning or Transferring Permit Coverage.....	68
3.4 After Construction is Complete	69
Chapter 4: City of Aurora Stormwater Quality Discharge Permit Inspections and Enforcement	72
4.1 Procedures and Processes	72
4.1.1 What to Expect.....	72
4.1.2 How to Comply	73
4.1.3 Coordination with City of Aurora	73
4.2 Inspection Process Phases & Enforcement Escalation	73
4.2.1 COA Stormwater Management and Erosion Control Inspections (SMEC).....	74
4.2.2 Enforcement Escalation.....	75
4.2.3 What will the COA Erosion Control Department be looking for?	78
4.2.4 What constitutes a COA Stormwater Quality Discharge Permit for Construction Activities violation?	79
4.2.5 Appeals Process for Reconsideration of Enforcement Action	79
4.2.6 City’s Ability to Recover Costs of Correction	80
Chapter 5: Permit Closeout	82
5.1 Summary of Permit Closeout Steps	82
5.2 Detailed Instructions for Permit Closeout	83
5.2.1 Preparation for the Closeout Inspection.....	83
5.2.2 Scheduling the Initial Closeout Inspection	84
5.2.3 Initial Closeout Acceptance	84
5.2.4 Special Closeout Requirements.....	84
5.2.5 Corrections to Site.....	85
5.2.6 Partial Acceptance of Phased Single-Family or Multi-Family Residential Projects	85

5.2.7 Establishment of Vegetation	85
5.2.8 Required Vegetation Coverage	86
5.2.9 Control of Noxious Weeds	87
5.2.10 Acceptance of Vegetation	87
5.2.11 Removal of On-site BMPs	88
5.2.12 Final Closeout Inspection	88
5.2.13 Release of Fiscal Security	88
Index	90

Appendices

Appendix A – Permit Application Forms

Appendix B – Enforcement Escalation Policy

Appendix C – Reserved

Appendix D – City of Aurora Standard Details for Temporary Construction Stormwater Best Management Practices (BMPs)

Appendix E –SWMP Narrative Report Template and Design Drawings Checklists

Appendix F – Standardized Probable BMP Cost Sheets

Appendix G – Guidance for Interpreting an Inspection Report

Appendix H – Colorado Noxious Weeds List

Appendix I – Reserved

Appendix J – Reserved

Appendix K – Cherry Creek Basin Authority Fact Sheets

THIS PAGE IS INTENTIONALLY BLANK

Introduction

Protecting the quality of stormwater runoff to streams is important to the City of Aurora, and is required by the Colorado Discharge Permit System (CDPS) Regulations. The policy described in this manual is pursuant to the City Code of the City of Aurora, Colorado, (<http://www.municode.com/resources/gateway.asp?pid=10331&sid=6>), Chapter 138 Utilities. The Colorado Department of Public Health and Environment (CDPHE), Water Quality Control Division (WQCD), through the Municipal Separate Storm Sewer System (MS4) permit issued to the City of Aurora, requires the City of Aurora to control and reduce the discharge of pollutants to protect stormwater quality and to satisfy the appropriate water quality requirements of the Colorado Water Quality Control Act (25-8-101 et seq., C.R.S.) and the Colorado Discharge Permit Regulations (Colorado Regulation No. 61). A part of the City's MS4 permit requires the City of Aurora to implement a program to reduce the discharge from public and private construction sites, and the process described herein is a part of the construction sites program the City is implementing.

I. 1 Purpose of Document

This volume, entitled *Rules and Regulations Regarding Stormwater Discharges Associated with Construction Activities*, sets forth the minimum requirements and process for obtaining a permit authorizing the discharge of stormwater from a construction site within the City of Aurora. The **City of Aurora Stormwater Quality Discharge Permit for Construction Activities** is the permit which allows the discharge of stormwater from a construction site within the City of Aurora. This manual explains the types of projects requiring such a permit, who gets the permit, and how the permit is obtained, including project design phase requirements. In addition, this manual describes the requirements and process for complying with the permit during construction, as well as the City's inspection and enforcement procedures, and the process for closeout of the permit.

Revisions to this document may be adopted annually and as often as needed. The policies herein may change without notice if it is found to no longer be effective and compliant with the City's MS4 requirements. It is the responsibility of applicants to obtain the latest revisions from the City.

City staff will review submittals for general compliance with the provisions herein. These provisions shall be regarded as the minimum requirements needed for the protection of the health, safety, and welfare of the people of Aurora.

I. 2 To whom does the City of Aurora Stormwater Quality Permit/Construction Activities pertain?

In general, all construction sites within the City of Aurora which disturb one acre of land or greater are subject to this process, including sites disturbing less than one acre that are part of a larger common plan of development or sale which will ultimately disturb one acre or greater. Disturbance and 'larger common plan of development' are defined by CDPHE (<http://www.cdphe.state.co.us/wq/PermitsUnit/stormwater/ConstFactSheet.PDF>) in the 'Stormwater Fact Sheet – Construction'. Individual home construction on lots less than one acre and located within a larger development requires a permit.

Chapter 1 of this manual describes in more detail the various industries and activities commonly involved in construction activities requiring a permit within the City of Aurora, including but not limited to residential, commercial, and industrial development, utility construction, city projects, and temporary batch plants.

I. 3 Relationship of the City of Aurora Stormwater Quality Permit/Construction Activities process to other City criteria and processes

The processes and requirements described herein are one part of a framework of requirements associated with development activity, and compliance with this process does not relieve a Permittee's obligations to comply with other applicable local, state (i.e. the Colorado Discharge Permit System, or CDPS), and federal criteria and regulations. For example, design of permanent stormwater-related infrastructure within the City of Aurora must comply with the City of Aurora Storm Drainage Design and Technical Criteria, design of utility infrastructure within the City of Aurora must comply with the Public Utility Improvements Rules and Regulations Regarding Standards and Specifications (PUIRRRSS), and design of roadways within the City of Aurora must comply with the Roadway Design and Construction Specifications.

I. 4 Why does the City regulate stormwater discharges from construction sites in Aurora?

Aurora is required to maintain an MS4 Permit with the CDPHE-WQCD. That permit authorizes the City to discharge stormwater from its municipal storm drainage system. Aurora's MS4 Permit requires the City to implement several stormwater management programs, including a program designed to reduce the discharge of pollutants from public and private construction sites. The City's construction sites program includes procedures for site planning, structural and non-structural best management practices (BMPs), procedures for site inspection and enforcement, and training and education for construction site operators. This manual and the

permit process it describes are a part of the City's implementation of its construction sites program.

I. 5 What Is The Relationship Between Federal, State, and Local Stormwater Permitting

I.5.1 EPA SWPPP Guidance Document Excerpt

"A. What Are the Federal Requirements for Stormwater Runoff from Construction Sites?"

The Clean Water Act and associated federal regulations (Title 40 of the *Code of Federal Regulations* [CFR] 123.25(a)(9), 122.26(a), 122.26(b)(14)(x) and 122.26(b)(15)) require nearly all construction site operators engaged in clearing, grading, and excavating activities that **disturb one acre or more, including smaller sites in a larger common plan of development or sale**, to obtain coverage under a National Pollutant Discharge Elimination System (NPDES) permit for their stormwater discharges. Under the NPDES program, the U.S. Environmental Protection Agency (EPA) can authorize states to implement the federal requirements and issue stormwater permits. Today, most states are authorized to implement the NPDES program and issue their own permits for stormwater discharges associated with construction activities.

Each state (or EPA, in the case of states that are not authorized) issues one or more NPDES construction general permits. These permits, generally, can be thought of as umbrella permits that cover all stormwater discharges associated with construction activity in a given state for a designated time period, usually 5 years. Operators of individual construction sites then apply for coverage under this permit. *Before applying for permit coverage, you should read and understand all the provisions of the appropriate construction general permit and develop a SWPPP. Because authorized states develop their own NPDES requirements, you should carefully read your state's construction general permit and follow the specific instructions it contains.* *Developing Your Stormwater Pollution Prevention Plan: A Guide for Construction Sites*, EPA-833-R-06-004, EPA, May 2007.
http://www.epa.gov/npdes/pubs/sw_swppp_guide.pdf

I.5.2 The State of Colorado Public Health Department – Water Quality Control Division

The State is authorized by the EPA to permit construction sites under their Colorado Discharge Permit System (CDPS) as described in I.6.1. According to the current CDPS General Permit language, "Local Agency Authority: This permit does not pre-empt or supersede the authority of local agencies to prohibit, restrict, or control discharges of stormwater to storm drain systems or other water courses within their jurisdictions."

I. 6 Variances & Appeals

1. Applicants or Permittees may request variances from BMP requirements and Stormwater Management Plans (SWMP) design requirements within the context of these rules and regulations. The procedure for requesting variances is described in Chapter 2, Section 2.2.3.
2. Applicants or Permittees may appeal COA enforcement actions and decisions on variance requests. The procedure for appeals is described in Chapter 2, Section 2.2.4 and again in Chapter 4, Section 4.2.5.
3. The City of Aurora will review and consider variance requests and formal appeals on their merits on a case-by-case basis.

I. 7 Grandfathering

1. Permits in place prior to the effective date, August 1, 2009, of these regulations may elect to be grandfathered from the following: additional permitting requirements of Chapter 1, Section 1.2; plans review requirements in Chapter 2; and, the fiscal securities requirement in Chapter 1, Section 1.4. The following exceptions apply.
2. All sites will be inspected according to the new regulation and therefore must meet and maintain all applicable SWMP requirements and best management practices (BMPs) of the “Rules and Regulations Regarding Stormwater Discharges Associated with Construction Activities.”
3. As existing BMPs become exhausted, overwhelmed or require replacement, BMPs will be expected to be updated per the current details in Appendix D unless a variance request is submitted.
4. Permits in existence prior to the effective date of these regulations will be exempt from the annual permit fee requirement in Chapter 1, Section 1.4; however, all permits in existence prior to effective date of these regulations will be required to renew their permit no later than one year from the effective date of these regulations and annually thereafter until the permit has been closed.
 - A permit transfer of a Grandfathered permit will be exempt from providing fiscal security, but will be subject to a new permit fee.
 - A reassignment of a portion of a Grandfathered permit will be exempt from providing fiscal security, but will be subject to a new permit fee.

5. Sites that have been dormant, with limited to no construction activity, for greater than 1 year (365 days) will no longer be eligible for grandfathering and will be required to meet all applicable requirements of the “Rules and Regulations Regarding Stormwater Discharges Associated with Construction Activities”, including submission of plans, submission of an updated SWMP, and fiscal security.
6. Sites that have existing SWMP plans must have adequate BMPs shown on the design drawings to address vertical construction or updates may be required.
7. All Builders and Developers that are currently operating and constructing under another Builder’s or Developer’s permit shall be required to obtain a new permit in their own name no later than October 1, 2011. The permit shall meet the requirements of these regulations including fiscal security and permit fees.

I. 8 Definition of Terms

Several definitions are printed here for convenience, but this is not intended to be an exhaustive list. Terms in this manual shall generally have the meaning assigned to them in the Code of Colorado Regulations.

Applicant: the entity requesting the permit from the City; the entity applying for the permit (see Chapter 1 of this manual for more information regarding applying for the permit).

Best Management Practice (BMP): a feature installed or procedure employed to manage stormwater, control site erosion, sediment or other potential pollution sources. Schedules of activities, prohibitions of practices, maintenance procedures, and other administrative practices to prevent or reduce pollution may also be referred to as BMPs. BMPs include treatment requirements, operating procedures and practices to control site runoff, spillage or leaks, sludge or waste disposal, or drainage from raw material storage.

Beta Testing: use of new or innovative BMPs for trial or demonstration and evaluation purposes.

City-owned Projects: for purposes of this manual, City-owned projects are projects in which the City either self-performs construction work or the City enters into a contract with a construction contractor for the purpose of constructing improvements that will be owned by the City. Projects on property dedicated to the City, but not yet accepted by all departments involved, shall not be considered City-Owned projects.

Commercial: refers to developments that include manufacturing, office, and retail facilities. This does not include residential development.

Construction: refers to the implementation of a proposed plan of improvements by a contractor that may include excavating, demolition, site grading, utility work, paving, building, and other activities that may contribute to the disturbance of land and elevated levels of environmental impacts, erosion and sediment.

Containment: containment is a sedimentation basin, berm, diversion, or other BMP which separates uncontaminated stormwater from the subject material.

Contamination: addition of pollutants to soil or groundwater that results in the impairment of water quality classifications or exceedance of water quality standards for any waters of the state, or a reasonable potential for any such impairment or exceedance.

Development: the process of creating new residential, commercial, office, or other land uses through the process of construction, clearing or installation of infrastructure.

Disturb: to alter the existing state of the environment by clearing, grubbing, grading, demolishing or building.

Disturbance area (for purposes of determining whether a permit is required): area affected by construction including but not limited to: grubbed areas, grading and excavation areas, staging areas, lay down areas, vehicle and equipment parking/storage/staging areas, construction areas, demolition areas, haul roads, access roads, stockpile areas, borrow areas, and trash enclosure areas.

Egregious Violations: activities or conditions which endanger public health or result in a documented impact to a stream. Egregious violations may also include: evidence of a discharge of pollutants, off-site release of sediment, flagrant washout violations threatening a storm sewer or drainageway, failure to address a Notice of Violation within the time allotted, or operating without a **COA Stormwater Quality Discharge Permit for Construction Activities** when one is required.

Final Stabilization: “means that all ground surface disturbing activities at the site have been completed, and all disturbed areas have been either built on, paved, or a uniform vegetative cover has been established with an individual plant density of at least 70 percent of pre-disturbance levels, or equivalent permanent, physical erosion reduction methods have been employed. Re-seeding alone **does not** qualify.” (CDPHE – Stormwater Fact Sheet 7/07)

Illicit Discharge: any discharge to a municipal separate storm sewer that is not composed entirely of stormwater except the following: discharges specifically authorized by a Stormwater Quality Discharge permit, and discharges resulting from fire fighting activities.

Imminent Failure: having reasonable potential to be immediately non-functional during a storm.

Larger Common Plan of Development or Sale: “is a site where multiple separate and distinct construction activities may be taking place at different times on different schedules.

Examples include:

- 1) phased projects and projects with multiple filings or lots, even if the separate phases or filings/lots will be constructed under separate contracts or by separate owners (e.g., a project where developed lots are sold to separate builders);
- 2) a development plan that may be phased over multiple years, but is still under a consistent plan for long-term development; and
- 3) projects in a contiguous area that may be unrelated but still under the same contract, such as construction of a building extension and a new parking lot at the same facility. If the project is part of a common plan of development or sale, **the disturbed area of the entire plan must be used in determining permit requirements.**

Disturbance associated with utilities, pipelines, or roads that are constructed for the purpose of serving a facility, are considered together with that facility to be part of a common plan of development. However, adjacent construction of trunk lines or roads that are part of a regional network and not directly associated with the facility construction, are not usually considered to be part of the common plan for that facility.” (CDPHE – Stormwater Fact Sheet 7/07)

Non-Contiguous areas that disturb one acre or more in a quarter mile (1/4) radius also fall into the category of a Larger Common Plan of Development.

A larger common plan of development is considered complete once the site has achieved final stabilization and all Stormwater Quality Permits have been closed.

Legally Responsible: For purposes of the permit application forms in the Appendix of this manual, ‘legally responsible’ means responsible for the overall operation of the proposed project from which the stormwater discharge will originate. In the case of projects contemplated by corporations, a responsible corporate officer or his/her duly authorized representative can sign the permit application as the ‘Legally Responsible Person’. In the case of projects contemplated by a partnership, a general partner or his/her duly authorized representative can sign the permit application as the ‘Legally Responsible Person’. In the case of projects contemplated by a sole proprietorship, the proprietor or his/her duly authorized representative can sign the permit application as the ‘Legally Responsible Person’. In the case of a project contemplated by a municipal, state, or other public entity, a principal executive officer or ranking elected official, or his/her duly authorized representative may sign permit applications as the ‘Legally Responsible Person’.

Living Document: Consists of the approved SWMP (narrative and design drawings), Permittee inspection reports and maintenance logs. These documents shall be kept on site and updated as conditions warrant in the field. See Chapter 3 for further information.

Maintenance logs: Permittee documentation showing corrective actions, repairs or replacements of BMPs resulting from the Permittee’s self inspections. These documents are required to be kept on site and are a part of the living document. These documents should reflect date of completion and initials of the SWMP administrator/designee acknowledging that the items have been completed

Master Developer: company, entity, or individual that plans and constructs infrastructure for building or homes.

Minor: having limited extent or low importance.

Multiple/Numerous: more than one.

Notice of Non-Compliance: (refer to Chapter 4 of this manual).

Notice of Violation: (refer to Chapter 4 of this manual).

Operator: entity that has day-to-day supervision and control of activities occurring at a construction site.

Owner: For purposes of the permit described herein, for non-City-owned projects, project Owners may be land owners who own the property, developers who either own the property or have an option on the property, utility companies who either own the property or have an easement, or developers completing public improvements on land dedicated to the City of Aurora for public purposes and /or land subject to dedication to the City of Aurora following satisfactory completion of construction. When dealing with leased land or facilities, the lessee shall be considered the “owner” for the purposes of stormwater permitting if they are responsible for the activities occurring at the site. When a permit is required for a contemplated project, a project Owner must sign the permit application form(s) in the Appendix of this manual. For City-owned projects (as defined above), the City is the project Owner. The property owner, whether or not they are the permittee, is still responsible for complying with City Code.

Perimeter Controls: construction stormwater BMPs employed at or near the construction or disturbance limits. See Chapter 2 for details regarding requirements.

Permittee (also Permit Holder): once a permit is issued, the applicant becomes the permittee and is responsible for compliance with conditions of the permit.

Pollutants: dredged soil, soil, slurry, solid waste, incinerator residue, sewage, sewage sludge, garbage, trash, chemical waste, biological nutrient, biological material, radioactive material,

heat, wrecked or discarded equipment, rock, sand, or any industrial, municipal, agricultural, or construction waste.

Pre-Disturbance: refers to the condition of a site before any development or grading occurred.

Process Water or Process Wastewater: For purposes of the Clean Water Act, "Process Wastewater" means any water which, during manufacturing or processing, comes into direct contact with or results from the production or use of any raw material, intermediate product, finished product, byproduct, or waste product. (40CFR 122.2)

Redevelopment: construction activities on an existing site with utilities, buildings, paving, landscaping, or other built features.

Significant Maintenance: activities which, if not performed, leave the BMP with reasonable potential to be immediately non-functional during a storm.

Site: the land or water area where any facility or activity subject to the COA Stormwater Quality Discharge Permit for Construction Activities is physically located or conducted, including adjacent land used in connection with the facility or activity.

Stop Work Order: (refer to Chapter 4 of this manual).

Substantial Completion of Grading: Stage of construction grading that is sufficiently complete to direct drainage through proposed final drainage paths, but not yet fine graded for Certificate of Occupancy.

Stormwater: precipitation runoff, snow melt runoff, surface runoff and drainage.

SWMP: a StormWater Management Plan. Stormwater Management Plans (SWMPs) consist of two parts: a narrative report and a set of plan view design drawings (refer to Chapter 2 of this manual for more information).

SWMP Administrator: (refer to Chapter 3 of this manual).

Temporary Batch Plant: a concrete or asphalt preparation plant on a site for which the land use, zoning, and planning approvals do not indicate a permanent concrete or asphalt plant. Portable mixing stations at which sacks of concrete are mixed are not considered temporary batch plants for purposes of this manual, but BMPs must still be used to contain materials at portable sack-concrete mixing stations.

Vertical Construction: involves the construction of all structures above ground, including, but not limited to, residences, commercial buildings, multi-level structures, single level structures, garages, storage areas, etc.

Watercourse/Waterway/Drainageway: any and all surface and subsurface water conveyance elements which are contained in or flow through the state, but not sewer systems, treatment works or disposal systems, potable water distribution systems, and all water withdrawn for use until use and treatment have been completed.

Waters of the State: any and all surface and subsurface waters which are contained in or flow through this state, but not waters in sewer systems, waters in treatment works or disposal systems, waters in potable water distribution systems, and all water withdrawn for use until use and treatment have been completed.

Chapter 1: Stormwater Quality Discharge Permit Basics for Construction Activities within City of Aurora

Any entity engaging in construction work for development or redevelopment projects, including clearing, grading, excavation, and other ground disturbance activities of more than one acre within the City of Aurora needs to obtain a **City of Aurora Stormwater Quality Discharge Permit for Construction Activities**. A Storm Water Management Plan (SWMP) must be developed and submitted by the applicant and approved by the City before the permit can be issued. As further described in Chapter 2, a SWMP identifies potential pollutant sources to stormwater, ensures that stormwater quality at a construction site is maintained, en route to water ways or the storm drainage system, through the implementation of best management practices (BMPs).

1.1 What Projects Require a City of Aurora Stormwater Quality Discharge Permit for Construction Activities?

In general, construction projects disturbing a total of one acre of land or more in the City of Aurora, projects disturbing less than one acre but part of a larger common plan for development or sale, projects within 100 feet of a watercourse, and temporary batch plants need a **COA Stormwater Quality Discharge Permit for Construction Activities**.

Proposed projects located within the **Cherry Creek Watershed** also must comply with the Cherry Creek Reservoir Control Regulation, Regulation No. 72 (5 CCR 1002-72). Approximately 15 square miles of the City of Aurora is also located within the Cherry Creek Watershed. The Cherry Creek Reservoir Control Regulation, Section 72.7, identifies specific requirements for erosion and sediment control BMPs on construction sites, and limits on the area of land that can be disturbed at any one time. For more information on the areas subject to the Cherry Creek Reservoir Control Regulation, and the specifics of the Regulation, please visit http://www.cherrycreekbasin.org/cc_sw_contractors.asp. Several fact sheets are provided on this website. Two fact sheets are provided in Appendix K for applicants' convenience.

1.1.1 Residential Development

Construction for development and redevelopment of residential houses that disturbs one acre or more of land or is part of a larger development in the City of Aurora requires a **COA Stormwater Quality Discharge Permit for Construction Activities**, to authorize the discharge of stormwater from the site. New development and redevelopment on sites less than one acre

that are part of a larger development also require a permit. The Cherry Creek Reservoir Control Regulation (described above) applies to residential development. In accordance with the Regulation, Section 72.7 (2)(b)(2), single home construction sites with less than 1 acre of disturbance are required to comply with the Cherry Creek Regulations (even when such sites may not require a COA Permit).

1.1.2 Commercial Development

Construction for development and redevelopment of office buildings, retail stores, gas stations, and any other commercial development which disturbs more than one acre of land or less than one acre but part of a larger common plan for development or sale in the City of Aurora requires a **COA Stormwater Quality Discharge Permit for Construction Activities** to authorize the discharge of stormwater from the site. This includes site demolitions. New development and redevelopment of sites less than one acre that are part of a larger common plan of development which will ultimately disturb one acre or more also require a permit. The Cherry Creek Reservoir Control Regulation (as described above) also applies to residential developments.

1.1.3 Utility Construction

The installation of underground dry and wet utilities such as for water, electricity, gas, television cable, internet, and others require a **COA Stormwater Quality Discharge Permit for Construction Activities** when:

- Disturbing more than one acre of land (see Introduction for a definition for Disturbance Area), or
- The utility installation site is less than one acre but is part of a larger project, or
- Installing underground utilities in excess of 1000 linear feet using open cut installation, or
- Utilizing trenchless technology for utility boring that has 1 acre or more of attributable construction disturbance area or is part of a larger common plan of development. (The use of BMPs is required to limit the discharge of stormwater and sediments into the public right of way at bore pit locations at all times and under all circumstances), or
- Installing utilities for a development, prior to the start of overlot clearing and grading.

New development and redevelopment on sites less than one acre that are part of a larger common plan of development or sale also require a permit.

Small public repair projects involving multiple small disconnected disturbance areas (i.e. alley repair or incremental utility line repairs), within a quarter mile radius, disturbing **less than 1 acre total**, and obtaining a street cut permit and license to work in the City of Aurora, will not be required to obtain a **COA Stormwater Quality Discharge Permit for Construction Activities**.

Small public repair projects involving multiple small disconnected disturbance areas (i.e. alley repair or incremental utility line repairs) within a quarter mile radius which result in one acre or more of total disturbance require submission of a SWMP to obtain a **COA Stormwater Quality Discharge Permit for Construction Activities Permit**.

1.1.4 City-Owned Projects

City projects disturbing more than one acre, or less than one acre but part of a larger common plan for development or sale, such as utilities, capital projects, parks and recreational facilities, pavement rotomilling as part of a new construction or redevelopment project, other pavement operations and the like require a **COA Stormwater Quality Discharge Permit for Construction Activities**. The definition of a 'City-Owned Project' for purposes of this manual is provided in the Introduction to this manual.

1.1.5 Temporary Batch Plants

Temporary batch plants require a **COA Stormwater Quality Discharge Permit for Construction Activities**, no matter the area of disturbance. Temporary batch plants require a separate permit even if they are located inside the limits of construction of an already permitted construction project. The definition of a Temporary Batch Plant is provided in the Introduction of this manual.

Permits for temporary batch plants are valid for one year from the date issued. Requests for renewal shall be made no later than 30 days prior to the expiration of the permit.

1.1.6 Cut and Fill Sites

Fill or excavation activities (i.e. stockpiles and borrow areas) that are not part of any of the project types listed above and involving 500 cubic yards of material or more require a **COA Stormwater Quality Discharge Permit for Construction Activities**. See Chapter 2 for detailed plan and permit requirements.

1.1.7 Mining Sites

Mining projects need a **COA Stormwater Quality Discharge Permit for Construction Activities**. This includes gravel pits. As with other types of projects, having a permit from the State of Colorado or other entities does not eliminate the requirement to obtain a permit from City of Aurora, just as having a permit from the City of Aurora does not relieve obligations to obtain required permits from the State of Colorado and other agencies having jurisdiction.

1.1.8 Projects exempted from City of Aurora Stormwater Quality Permit/Construction Activities

Some projects (listed below) are exempt from the **COA Stormwater Quality Discharge Permit for Construction Activities**.

- Routine agricultural practices including tilling, planting, harvesting, or livestock operations and grazing
- Pavement repair on public and private roadways such as pothole repair and pavement patching (BMP installation and Right-of-Way permit still required)
- Asphalt pavement rotomilling that is only for street maintenance purposes and has no other construction associated with it. BMPs are still required to be implemented.
- Emergency situations that pose an imminent risk to life or property, such as hazardous waste clean-up operations and fire
- Surveying
- Geotechnical boring investigations, utility locating, potholing
- Emergency utility repairs
- Mowing
- Weed control
- Controlled burning
- Fencing and maintenance of existing fencing
- Other: COA, E-470, or CDOT projects that may have sound barrier wall installations not allowing drainage to pass through (BMP installation still required).
- City erosion abatement projects
- Pavement repair and replacement on public trails with less than one acre of disturbance.
- Eligible non-standard MS4 permitted sites

Projects which are exempt from this permit are not free from the obligation to control erosion and sediment at the construction site. See Chapter 2, Section 2.2.2.1.i for Civil Plan information requirements.

1.2 Who Obtains the Permit?

1.2.1 Master Developers

Master Developers must obtain a **COA Stormwater Quality Discharge Permit for Construction Activities** prior to beginning initial construction activities such as grading of the lots and roads. Permittees remain responsible until the permit is closed out as described in this manual, or until other party(ies) obtain permit coverage for the permitted area. For example, a Master Developer may elect to continue maintaining certain BMPs receiving runoff from the sites of one or more builders within a Master Development, and/or a Master Developer may elect to enter into sales or other agreements in which certain builders or others will obtain permit coverage for certain areas within the Master Development. The permittee cannot be released from their permit until a new permittee has accepted the permit responsibilities or final stabilization has been achieved and approved.

1.2.2 Builders

Builders (constructors) are required to obtain a **COA Stormwater Quality Discharge Permit for Construction Activities** for vertical construction, before beginning post-paving and vertical construction on a development site. This may either be a new permit or a transfer or partial transfer of a permit. It should be noted that any type of transfer commits the new permittee to following all previously approved existing SWMP documents and requirements. These should be thoroughly examined before accepting a transfer. An amendment, variance requests, or a new SWMP may be submitted if the existing SWMP is disagreeable to the transferee. It should be noted that all of these submittals have review times associated with them.

1.2.3 City

When any City department engages in construction projects, the City's contractor performing the construction contract must obtain a **COA Stormwater Quality Discharge Permit for Construction Activities** before construction can begin.

1.2.4 Utility Builder

A utility builder operating inside or outside of a Master Development area, disturbing one acre or more of land, or using trenchless construction techniques disturbing an acre or more of land, is required to obtain a **COA Stormwater Quality Discharge Permit for Construction Activities** prior to beginning construction. The exception is if the permittee for an overall development will allow the Utility Builder to operate under their existing permit, then no new permit is required. The Utility Builder is then required to comply with all existing permit requirements and the SWMP should be thoroughly reviewed prior to utility installation construction beginning.

1.2.5 Operator of a Temporary Batch Plant

A temporary batch plant operator is required to obtain a **COA Stormwater Quality Discharge Permit for Construction Activities** prior to beginning the batch plant operation. The permit is required regardless of whether the batch plant is located on a permitted construction site.

The land owner or project owner may be one of the above entities, or another entity, depending on the project type and the business arrangements related to the specific project. In some cases, owners elect to apply for permits. In other cases, owners or developers elect to engage others to perform certain services such as applying for permits. Aurora requires the entity applying for the permit to sign the application for the permit. In addition, in cases where the entity applying for the permit is other than the owner, Aurora also requires the owner to sign the application for the permit.

1.3 What Type of Permit is Required?

1.3.1 Local

The **COA Stormwater Quality Discharge Permit for Construction Activities** is required for construction activities within the City of Aurora and disturbing one acre of land or more, and construction activities which may disturb less than one acre but are part of a larger common plan of development which will disturb one or more acres of land.

1.3.2 Other Permits and Requirements Apply

Having a permit from the City of Aurora does not relieve obligations to obtain required permits from the State of Colorado and other agencies having jurisdiction. Having a permit from the State of Colorado or other entities does not eliminate the requirement to obtain a permit from City of Aurora. In the case of bigger projects which span multiple jurisdictions (i.e. road or pipeline construction, utility installations), cooperation between the City and the county and/or other agencies having jurisdiction is needed. Multiple local permits may be required in addition to other permits.

State and Federal permits are also required for many construction activities. Contact the Colorado Department of Health and Environment (CDPHE) Water Quality Control Division (WQCD) for necessary construction-related stormwater discharge and other permits, such as the Colorado Discharge Permit System (CDPS) permits, which may include for example, dewatering, Minimal Industrial Discharge (MINDI) permits, or others. Contact the Army Corps of Engineers

for permits related to activities within or near wetlands or Waters of the US, pursuant to the Clean Water Act section 404.

All contractors working within the City of Aurora shall comply with the “Colorado Water Quality Control Act” (Title 25, Article 8, CRS), the “Protection of Fishing Streams” (Title 33, Article 5, CRS), the “Clean Water Act” (33 USC 1344), regulations promulgated, certifications or permits issued, and the requirements contained in this manual. In the event of conflicts between these requirements and water quality control laws, rules, or regulations of other Federal or State agencies, the more restrictive laws, rules, or regulations shall apply.

1.4 How Does One Obtain a City of Aurora Stormwater Quality Discharge Permit for Construction Activities?

Most development within the City requires several phases of plan review and permitting. Typically a framework development plan or master plan is prepared, a subdivision is platted, a site plan is prepared and approved, and then civil plans and building plans are prepared, reviewed and revised until approved for signed ‘mylar’ or file drawings. The stormwater management plan (SWMP) required as part of the **COA Stormwater Quality Discharge Permit for Construction Activities** approval process is typically reviewed by the City’s design review team during the Civil Plans Review process.

When the Civil Plans Review process is completed (SWMP is approved), and the applicant is ready to start construction, apply and obtain COA Stormwater Quality Permit, attend Erosion Control Kick-Off Meeting, if necessary, have BMPs inspected at the site by a City of Aurora Water Department Erosion Control Program Staff Member, and if the site passes, the **COA Stormwater Quality Discharge Permit for Construction Activities** is signed and construction can begin.

The permitting phase of the **COA Stormwater Quality Discharge Permit for Construction Activities** process shown in Exhibit 1-1 below begins with the approval of civil plans and the stormwater management plan (SWMP). Design phase guidelines for SWMP preparation are provided in Chapter 2. Refer to Appendix A for necessary forms.

1.4.1 How to Obtain a Permit

The general process to obtain a permit is outlined as follows:

1. SWMP designed by Colorado licensed engineer
2. Schedule and attend Pre-Submittal meeting with Public Works and Aurora Water (call 303-739-7300 to schedule).

3. COA conducts plan reviews, engineer revises SWMP as needed to obtain COA approval (typically as part of Civil Plans Review process).
4. Obtain City Engineer and Water Department signatures (upon approval of SWMP)
5. Fill out the **COA Stormwater Quality Discharge Permit for Construction Activities** application form (Appendix A).
 - a. When a facility or activity is owned by one entity, but another entity is applying for the permit, both the applicant and the owner shall sign the permit application and the permit will be issued to both parties as co-permittees.
 - b. The application form shall be signed as follows:
 - In the case of corporations, by a responsible corporate officer or his/her duly authorized representative.
 - In the case of partnership, by a general partner or his/her duly authorized representative;
 - In the case of a sole proprietorship, by the proprietor or his/her duly authorized representative;
 - In the case of a City-owned project, by the City project manager.
6. Take application form, permit fee, and required fiscal security to Permit Center for additional execution. The Permit Center is located on the second floor of the Aurora Municipal Center, 15151 East Alameda Parkway.
 - a. The amount of fiscal security for a SWMP permit is based on the standardized probable cost sheets for installing and maintaining BMPs (given in Appendix F). The fiscal security amount is 25% of the subtotal for all BMPs and is the same dollar amount as the Maintenance amount. If there are both Initial and Post-Paving plans, the required fiscal security is the higher amount of the two calculated Fiscal Security amounts and not the total of both. The standardized probable cost worksheets shall be filled out, submitted, and approved as part of the SWMP.
 - b. The fiscal security must remain valid and in effect until a passing final closeout inspection is achieved.
 - c. Currently accepted forms of Fiscal Security are performance bonds and cash, which will be held in a non-interest bearing account until the permit is closed.
 - d. Performance bonds shall meet the following requirements:

- Must name the City of Aurora as the Obligee
 - Must tie the performance to, "the City of Aurora Stormwater Quality Discharge Permit associated with (legal name of the project per the approved plat)"
 - Must not have an expiration date unless good cause is shown for a proposed date.
- e. Projects funded by City of Aurora are exempt from supplying fiscal security, but are required to pay the annual permit fee.
7. Contact the COA Erosion Control Supervisor (720-859-4415) to determine whether an Erosion Control Kick-Off meeting with the COA is required prior to implementing initial BMPs on the site.
 8. Install initial BMPs on the construction site, per the SWMP, the SWMP narrative report and per COA details included in this manual.
 9. Obtain initial site inspection and final COA Water Department Erosion Control Program Staff signature.
 - a. The permittee applying for a stormwater discharge permit must request and receive a passing initial inspection from a COA Water Department Erosion Control Program Staff member prior to engaging in any earthwork. The inspection must be requested 72 hours in advance of the inspection date.
 - b. During the initial inspection, the COA Water Department Erosion Control Program Staff member will verify the installation of appropriate initial BMPs for the project and execute the Permit, authorizing the permittee to begin work.
 - c. The permittee is required to produce the site's CDPHE *Stormwater Discharges Associated with Construction Activity Permit* (if one is required for the project) and the *certification of coverage* during the initial inspection.
 - d. If the initial inspection is failed, then the Permit will not be executed and BMP installation must be corrected and re-inspected prior to engaging in any earthwork activities.
 10. The COA signature following a passing initial site inspection begins the **COA Stormwater Quality Discharge Permit for Construction Activities** coverage and authorizes construction activities to begin. The permit is valid for one year from

the date the permit is granted. The permit shall be renewed at least fourteen (14) days prior to its expiration date. The application form (in Appendix A) and permit fee in effect at the time of renewal must be submitted to renew permit coverage. The "RENEWAL" box should be checked on the application form when applying to renew permit coverage.

11. For information on re-assigning and transferring permit coverage, refer to Chapter 3, Section 3.3.5.

During the construction phase, routine inspections are conducted by the City's Water Department Erosion Control Program Staff, to ensure that the site continues to comply with the **COA Stormwater Quality Discharge Permit for Construction Activities**. More information on construction phase requirements is provided in Chapter 3.

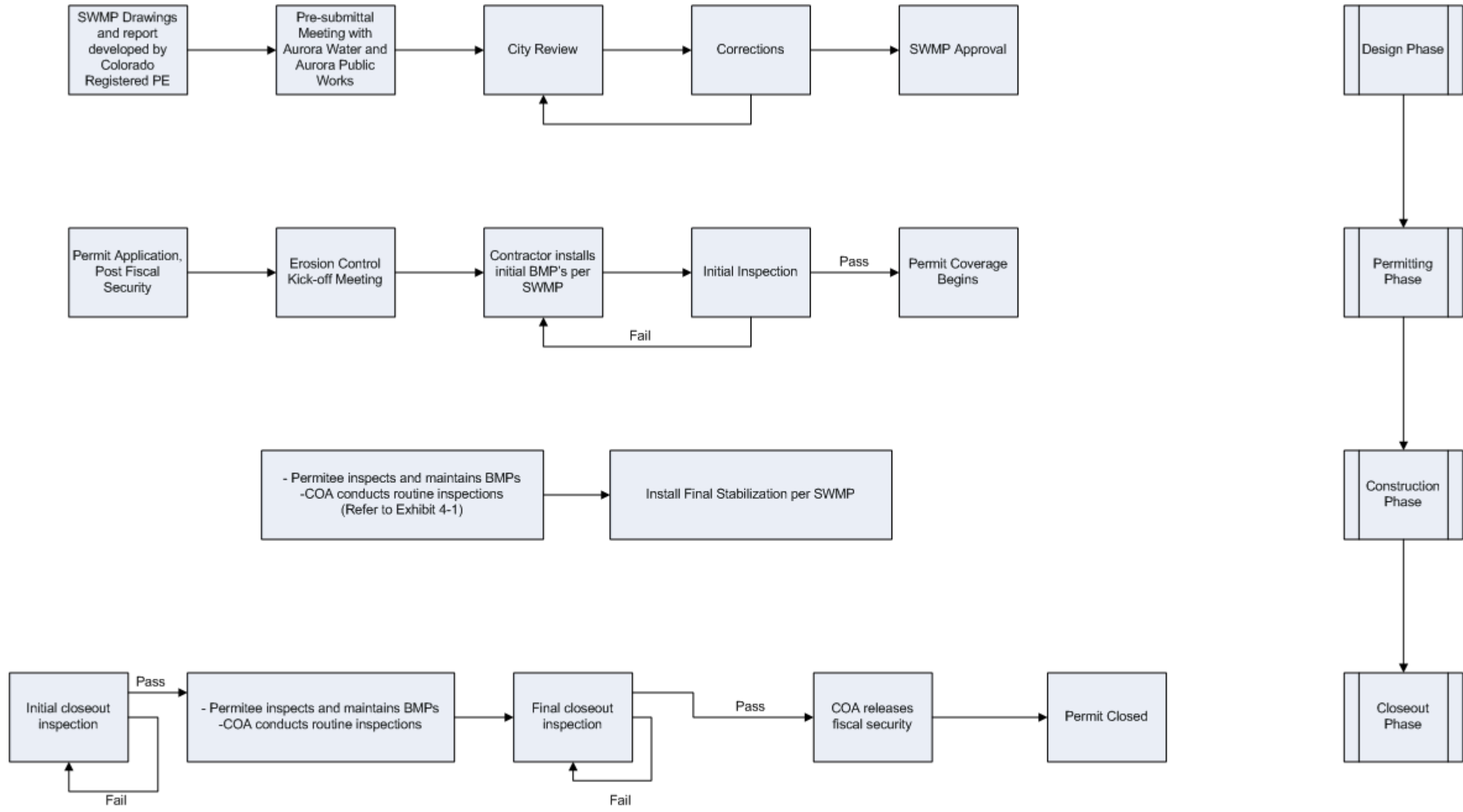

Exhibit 1-1
COA Stormwater (Quality) Discharge Permit for Construction Activities – General Process Overview

* For more information on pre-construction meetings, including pre-submittal and erosion control kick-off, refer to chapter 3.

PAGE INTENTIONALLY LEFT BLANK

Chapter 2: Design Phase Requirements

During the design phase of a proposed construction project within the City of Aurora, applicants must submit a Stormwater Management Plan (SWMP), which is comprised of a narrative report and design drawings with detailed information on proposed BMP installation at the construction site, in accordance with COA requirements described herein.

2.1 Design Phase Overview

Construction stormwater Best Management Practices (BMPs) are temporary BMPs required during construction activities and land disturbance, to protect the quality of stormwater runoff by retaining most sediment and other potential pollutants on site. BMPs are required during the entire duration of the construction. The SWMP narrative report and associated design drawing set must describe the system of construction stormwater BMPs that will be used to protect stormwater quality during the phases of construction. Perimeter controls should only be removed after site stabilization, at permit closeout. More information on permit closeout is provided in Chapter 5.

For proposed construction activities within the **Cherry Creek Watershed**, applicants must also comply with the Cherry Creek Reservoir Control Regulation No. 72. Information on specific additional BMP design requirements for projects located within the Cherry Creek Watershed can be found online: http://www.cherrycreekbasin.org/cc_sw_contractors.asp.

The sections below describe the City of Aurora’s requirements for SWMP narrative reports and design drawings.

2.2 Design of System of Construction Stormwater BMPs and Preparation of Stormwater Management Plan (SWMP)

In general, a SWMP must be submitted and approved in order to get a **City of Aurora Stormwater Quality Discharge Permit for Construction Activities**.

A SWMP consists of two parts: a narrative report and design drawings. SWMPs are typically submitted and reviewed as part of the COA civil plans review process. As stated in CDPHE-WQCD’s SWMP Preparation Guidance, the goal of a SWMP is: *“To identify possible pollutant sources that may contribute pollutants to stormwater, and identify BMPs that, when implemented, will reduce or eliminate any possible water quality impacts.”* A SWMP must be prepared and submitted during the design phase so that it is ready to be implemented at the start of construction. *The SWMP and the checklists for SWMP preparation in Appendix E must*

be signed by a Professional Engineer (PE). This checklist is only used for evaluating the completeness of the SWMP for acceptance at the Pre-Submittal meeting. Later, during construction, SWMPs need to be re-evaluated and updated regularly in the field as construction advances, to make sure they continue to accurately reflect the work activities, site conditions, and BMPs needed.

Items that should not be included in a SWMP narrative report being submitted for review and approval by the City include; Consent Decrees, this SWMP Manual, the CDPHE permit and guidelines, alternative language versions of details, Cherry Creek Basin Regulations and Guidelines, and any other documents that are not specifically pertinent to the review and approval of the narrative report information as it relates to the City of Aurora criteria. Such documents may be added after approval as part of the field SWMP along with the approved SWMP.

SWMP narrative reports for projects within the COA shall follow the outline provided below and shall utilize the SWMP narrative report template.

2.2.1 Standard COA SWMP Narrative Report Requirements

Cover

The cover shall include the subdivision name and filing number, and list the contact information for the Owner/Developer and Consultant.

The cover of the Stormwater Management Plan (SWMP) Narrative Report must include this COA signature block:

APPROVED FOR ONE YEAR FROM THIS DATE	
City Engineer	Date
Aurora Water Department	Date

Signature Page

The following statements and signature lines should occur on the first page of the Stormwater Management Plan Narrative Report after the cover.

“THIS STORMWATER MANAGEMENT PLAN HAS BEEN PLACED IN THE CITY OF AURORA FILE FOR THIS PROJECT AND HAS BEEN DETERMINED TO COMPLY WITH THE APPLICABLE CITY OF AURORA STORMWATER MANAGEMENT CRITERIA. ADDITIONAL STORMWATER MANAGEMENT, EROSION AND SEDIMENT CONTROL MEASURES MAY BE REQUIRED OF THE OWNER OR HIS/HER AGENTS, DUE TO UNFORESEEN EROSION PROBLEMS OR IF THE SUBMITTED PLAN DOES NOT FUNCTION AS INTENDED.”

“REVIEW OF THIS PLAN BY THE CITY OF AURORA SHALL NOT IMPLY THAT IT HAS BEEN REVIEWED FOR COMPLIANCE WITH THE REQUIREMENTS SET FORTH BY THE STATE OF COLORADO DEPARTMENT OF PUBLIC HEALTH AND ENVIRONMENT GENERAL PERMIT FOR STORMWATER DISCHARGES ASSOCIATED WITH CONSTRUCTION ACTIVITY.”

“SEE APPROVED STORMWATER MANAGEMENT DESIGN DRAWINGS (SITE PLAN) FOR SITE SPECIFIC BEST MANAGEMENT PRACTICES.”

The following signature block shall be included and signed on the first page after the cover. The Plan Preparer signature block shall be signed and stamped by the Colorado licensed professional Engineer.

Project Owner/Developer Signature Block

I have reviewed the information contained within the Stormwater Management Plan and accept responsibility for the requirements set forth.

Permittee/Affiliation (type actual name)

Date

Plan Preparer Signature Block

I acknowledge my responsibility for the preparation of the Stormwater Management Plan.

CO Professional Engineer (type actual name)

Date

Standard Required Statement and Notes for SWMP Narrative Reports

The following statement and notes shall be included in the SWMP Narrative Report following the signature page.

"Pursuant to Sections 138-440 and 138-442 of the Aurora Municipal Code, the Permittee shall locate, install, and maintain all Best Management Practices, including, but not limited to, erosion controls, sediment controls, drainage controls, and water quality BMPs as indicated in the approved Stormwater Management Plan (SWMP). The following notes are a requirement and shall be included in the SWMP narrative developed for this project and submitted for approval by the City. BMP installations shall be installed per the COA Standard Detail in effect at the time of installation or per the approved SWMP design drawing, a

COA approved variance, or a COA approved design drawing plan amendment."1. A City of Aurora Stormwater Quality Discharge Permit for Construction Activities must be issued by the City and executed by a COA Erosion Control staff prior to any earthwork activities. An on-site inspection will be conducted to verify the correct installation and adequacy of initial BMPs for the site. No earthwork, including clearing and grubbing, or demolition activities are to begin until the project site has passed an inspection and the City of Aurora Stormwater Quality Discharge Permit for Construction Activities has been executed. The Permittee is required to present the project's CDPHE-WQCD Stormwater Discharges Associated with Construction Activity Permit to the Inspector during the initial inspection. The Permittee shall designate a Stormwater Management Plan (SWMP) Administrator on the application for the City of Aurora Stormwater Quality Discharge Permit for Construction Activities. The SWMP Administrator will act as the project representative for any concerns or issues regarding environmental controls and stormwater management.

2. These requirements shall be the obligation of the Permittee, until such time as the Permit is properly closed, or otherwise allowed by the City to be voided, modified, transferred, re-assigned or replaced.

3. This SWMP narrative, the SWMP design drawings, and the Permittee's inspection and maintenance records are all components of required record keeping and shall be kept on site at all times and updated as required. These and any other pertinent records shall be provided to the City when requested.

4. Any discrepancy between this SWMP and any other approved Stormwater Management Plan for this site shall require compliance with the more restrictive valid, approved plan.

5. Streets shall be constructed with Rough Cut Street Control measures, surface roughened or otherwise temporarily stabilized with rough cut street controls within seven (7) days of completion of grading in the appropriate phase. If paving is to occur within fourteen (14) days after final grading, rough cut street controls shall be waived.

6. Inspection and maintenance of erosion and sediment control Best Management Practices (BMPs) are the continuous obligations of the Permittee. (BMPs) shall be inspected at a minimum every seven (7) days and within 24-hours after the end of a precipitation event that produces run-off, and following snowmelt events. If a site is temporarily idle and no construction activities will occur during the 48 hours following a storm event, the post-precipitation event (including snowmelt) inspection shall be conducted prior to commencing construction activities on the site, but no later than 72 hours following the storm event. All necessary maintenance and repairs shall be initiated and completed on an on-going basis, as features are required to operate continuously. Inspections may need to be conducted at a greater frequency than noted above, to ensure features and systems are operating adequately. Erosion and sediment control BMPs shall be maintained and functional for the entire duration of the project.

7. Ingress and egress vehicle access points onto disturbed areas shall be stabilized with Vehicle Tracking Control Pads (VTC) and shall be constructed with angular rock, 3" to 6" in size and to a depth of at least 9-inches. The use of recycled asphalt or concrete is not permitted. The VTC shall be installed over a liner of non-woven geotextile with a weight of at least 10 oz/yd² and a grab tensile strength of at least 250 pounds. No dirt or other materials shall be placed on paved surfaces or curb flow lines to act as curb ramps. Only metal ramps or rock wattles may be used in the curb flow line.

8. Fugitive dust emissions resulting from grading activities and/or wind shall be controlled using reasonably available control technology as defined by the Colorado Department of Public Health and Environment.

9. All potential pollution sources on-site shall be identified and control measures installed and practiced to minimize the likelihood of a release. Spill prevention controls shall be developed for the site with BMPs in place to respond to any spills, leaks or other releases.

10. Hydraulic mulching as a means to cover and protect seeding is not an acceptable means of applying mulch in the City of Aurora unless a previously installed irrigation system is used to aid germination and growth and where approved through variance. Hydraulic seeding is not permitted.

11. For all porous landscape detention facilities, in order to prevent clogging of filter medium, installation of the filtration system must be delayed until after the site is fully landscaped.

12. If stockpiles are located within 100 feet of a drainageway or a public storm sewer system, additional sediment controls such as temporary diversion dikes, silt fence, or sediment basin shall be required.

Table of Contents

SECTION 1 SITE DESCRIPTION

- i. Site location including, Section, township, range, and latitude and longitude to the nearest 15 seconds.

If applicable, specific acknowledgement that the land is currently, or will ultimately be owned or managed by the Parks, Recreation and Open Space Department.

State if the project is considered a federal facility.

Applicable State and City permit numbers.

- ii. A description of adjacent areas such as residential areas, roads, streams, lakes, etc, which might be affected by the proposed project's land disturbing activity.

- If applicable, specific acknowledgement that the land is currently, or will ultimately be owned or managed by the Parks, Recreation and Open Space Department.

a) Nature and Purpose of Construction Activity

A description of the nature and purpose of the construction activity.

b) Construction Sequence

The proposed sequence for major activities should be described, including :

- An estimated project start
- An estimated project end date
- The sequence of major construction activities (Initial, interim, final or overlot grading, utilities, building, paving over – excavation, etc.). This is expected to be a brief overview of the project as more detailed phasing information will be addressed in later sections of the SWMP narrative report.

c) Area

Provide estimates of the total area of the site and the disturbed area within the site expected to undergo clearing, excavation or grading. Include an estimate of the excavation and fill volumes involved during the proposed construction, an estimate of how excavation and fill will be phased, an estimate of over-excavation areas and volumes, and an estimate of offsite trucking volume (import and/or export). If exporting material to an area within the COA limits, the receiving site must have its own SWMP and may be required to have its own COA Stormwater Quality Discharge Permit. If the export site is outside of COA limits, then the requirements of that local jurisdiction must be met and proof of a valid permit for the site will be required.

d) Topography, Soils, and Rainfall Data

Provide information describing the soil, the soil type, and hydrologic soil group, permeability, texture, soil erosion potential, depth, soil structure, etc. and potential impacts of the soil type on the quality of any stormwater discharge from the site. A description of the topography of the site, existing site conditions, drainage patterns, and existing site slopes should also be included. Imperviousness and runoff coefficients shall also be provided. A soils map showing the site limits and excerpts regarding the soils information shall be placed in the SWMP narrative report appendices

e) Existing Vegetation

Provide a description of the existing vegetation at the site and an estimate of the percent vegetative cover density prior to disturbance in an average square yard of the site. If the site has been previously disturbed, then an estimate of the original vegetative density shall be used. This estimate is not for area of coverage, but is for the average density of plant coverage for the site. A plan showing the existing major trees (4" diameter trunks and larger), tree masses, and shrub masses should be provided.

f) Potential Pollution Sources

Identify and list the proposed location and description of any potential pollution sources anticipated to be used during the project. Materials of concern may include, but are not limited to, portable toilets, vehicle fueling, grout/cement mixers, storage of fertilizers, paints or chemicals and stockpiles, raw materials, fuels, metallic products, hazardous substances designated under Section 101(14) of the Comprehensive Environmental Response, Compensation, and Liability Act (CERCLA), any chemical the facility is required to report pursuant to Section 313 of title III of the Superfund Amendments and Reauthorization Act (SARA), fertilizers, pesticides, ash, slag, sludge concrete washout, paints, solvents, and waste piles.

This is expected to be a list with detailed information being addressed in later sections of the SWMP narrative report.

g) Non-stormwater Discharges

Identify and list the location and description of any anticipated non-stormwater components of the discharge, such as springs (State permit required), potable water for dust suppression, landscape irrigation return flow, pipeline dewatering (i.e. Waterline flushing and testing), diverted stream flows, flows from wetlands, fire-fighting activities, hydrant blow-offs, building power-washing where detergents are not used, construction dewatering of groundwater (State permit may be required), uncontaminated air conditioning or compressor condensate, foundation or footing drains where flows are not contaminated with process materials such as solvents (State permit may be required), or other discharges specifically authorized by a separate National Pollutant Discharge Elimination Systems (NPDES) permit or a separate Colorado Discharge Permit System (CDPS) permit etc

h) Receiving Waters

List the name of all potential receiving water(s) and the size, type and location of any outfall. If the discharge is to a municipal storm sewer system, then provide the name of that system, the location of the storm sewer discharge, and the ultimate receiving water(s). State whether or not there are wetlands, the 100-year floodplain status of the site (i.e. If the site is within/near a floodplain or not), if the receiving water is impaired or not, and if there are any stream crossings proposed. Floodplain maps shall be provided in the SWMP narrative report appendices and shall show the site in relation to the floodplain.

If any of the water bodies are impaired and/or subject to Total Maximum Daily Loads (TMDLs), shall list the pollutants causing the impairment and any specific requirements in the TMDL(s) that are applicable to construction sites. The SWMP narrative report should specifically include BMPs to reduce to the maximum extent practicable the discharge of these pollutants.

i) Site Features and Sensitive Areas to be Protected

The SWMP narrative report shall describe unique site features including streams, stream buffers, wetlands, specimen trees, natural vegetation, steep slopes, or highly erodible soils that are to be preserved and the BMPs to protect those features.

Other Applicable Federal, or State Programs, Regulations, or Restrictions

State any other regulations that are affecting the site.

1. **Endangered Species** - State whether or not there are any endangered species or critical habitats on or near the site. If so, then describe the impacts and the measures being taken to address that impact.
2. **Historic Preservation** - State whether or not there are any historic sites on or near the site. If so, then describe the impacts and the measures being taken to address that impact. Site Features and Sensitive Areas to be Protected

SECTION 2 SWMP DESIGN DRAWINGS

In addition to the narrative report, SWMP design drawings must be submitted, indicating the types, locations, and extents of BMPs proposed for installation on the project site. Requirements for SWMP design drawings for construction within COA are discussed in Section 2.2.2. Approved design drawings shall be kept with the approved narrative report in the field and must be kept current. See COA SWMP Manual Chapter 3 for more information regarding SWMP updates. For most projects, a series of site maps is recommended. The first should show the undeveloped site and its current features. An additional map or maps should be created to show the developed site or for more complicated sites show the major phases of development.

SECTION 3 STORMWATER MANAGEMENT CONTROLS

This section shall describe the stormwater management controls that will be used to control pollutants in stormwater discharge during construction activity.

a) SWMP Administrator and Important Contacts

List Contact names and phone numbers for the SWMP Administrator, alternates, owner, developer, etc

b) Identification of Potential Pollutant Sources

All potential pollutant sources, including materials and activities, at a site must be evaluated for the potential to contribute pollutants to stormwater discharges. The SWMP shall identify and describe the sources of potential pollutants to stormwater discharges. At a minimum, each of the following sources and activities shall be evaluated for the potential to contribute pollutants to stormwater discharges, and identified in the SWMP if found to have such potential:

- all disturbed and stored soils (borrow areas and stockpiles)
- vehicle tracking controls and clean up
- management of contaminated soils
- loading and unloading operations
- outdoor storage areas (building materials, fertilizers, chemicals, etc.)
- vehicle and equipment maintenance and fueling
- significant dust or particulate generating processes
- routine maintenance activities involving fertilizers, pesticides, detergents, fuels, solvents, oils, etc.

- on-site waste management practices (waste piles, liquid wastes, dumpsters, etc.)
- concrete truck/equipment washing, including the concrete truck chute and associated fixtures and equipment
- dedicated asphalt and concrete batch plants
- non-industrial waste sources such as worker trash and portable toilets
- other areas or procedures where potential spills can occur
- Stormwater or groundwater dewatering

c) BMPs for Stormwater Pollution Prevention

The SWMP narrative report shall include a narrative description of the appropriate controls and BMPs that will be implemented before, during and after construction activities at the project site to manage and control the runoff of pollutants.

The SWMP narrative report shall clearly describe the relationship between the phases of construction, and the implementation and maintenance of BMP controls. For example, the report must indicate which controls will be implemented during each of the following phases of construction: clearing and grubbing for perimeter controls, installation of initial BMPs, clearing and grubbing, overlot grading, installation of interim BMPs, site construction, utility construction, vertical construction, other pertinent construction phases, final grading, stabilization, removal of BMPs, and Permit closeout.

1) Structural Practices

A description of initial, interim, and permanent structural site management practices to control erosion and sediment transport. Practices may include, but are not limited to: silt fences, diversion dikes, sediment traps, sediment basins, temporary slope drains, inlet protection, outlet protection, check dams, curb/rock socks, vehicle tracking control pads, sediment control logs, compacted earthen berm, and terracing.

2) Non-Structural Practices

A description of initial, interim and permanent stabilization practices, including site specific scheduling of the implementation of these practices. Site plans should ensure that existing vegetation is preserved where possible and that all disturbed areas are stabilized. Non-structural practices may include, but are not limited to: temporary seeding, permanent seeding, mulching, sod stabilization, vegetative buffer strips, tree protection, landscaping, erosion control blankets/matting, soil retention matting, street sweeping, and preservation of mature vegetation.

3) Phased BMP Implementation

The SWMP narrative report must clearly describe the various phases of construction and the implementation of BMPs to be used during each phase. Indicate which controls will be implemented during each of the following phases of construction: prior to clearing and grubbing for perimeter controls (installation of initial BMPs), clearing and grubbing, overlot grading, installation of interim BMPs, site construction, utility construction, vertical construction, other pertinent construction phases, final grading, stabilization, removal of BMPs, and Permit closeout. Other examples of project phases may include, but are not limited to, demolition, over-excavation, road construction, fine grading, and final stabilization.

The description for a particular phase may have sub-phases. For example the Overlot grading of an 80 acre site may have to describe multiple sub-phases due to the 40 acre disturbance limitation. Another example would be vertical construction phase may describe sub-phases of the construction such as grading, foundations, framing, finishing, and stabilization.

a. Overlot Grading Specific Practices

- Overlot grading specific practices should address items such as: surface roughening, blanketing, terracing, mulching, temporary seeding, permanent seeding, temporary sediment pond construction and removal, phasing, haul routes, disturbance limits, etc.
- Haul routes may be designated on the SWMP updates and shall take into consideration drainage, erosion and sediment control BMPs, along with interim stabilization measures.
- Due to the large areas of disturbance that occur with overlot grading, interim stabilization may be provided via plan amendment by the contractor and the engineer at the Erosion Control Kick-Off meeting. These measures shall be provided with timeframes and down gradient controls.
- Temporary drainage BMPs (diversion ditches, sediment traps or sediment basins) shall be maintained at all times and the SWMP narrative shall discuss timing and procedural requirements for implementation, maintenance and removal of these items during this period of construction.

b. Vertical Construction Specific Practices

Vertical construction is an important component to a site's development. In preparing the SWMP, include a section for vertical

construction BMPs if the site requires building construction. BMPs may include but are not limited to:

- Provide a mixing station detail/area for masonry/brick. If the site is going to bring in silos for masonry mixing, wind protection will be required to minimize the maximum extent practicable the dust from impacting adjacent buildings and streets.
- Saw cutting station detail/area (must address slurry waste)
- Procedural BMPs for clean up in the above areas and clean up if spills should occur as traveling to the building area
- Options for handling paints, solvents, glues (i.e. utilize the CWS or provide alternative)
- Provide physical and procedural BMPs for clean up along the building during the installation of brick, stone or stucco (strike zone and scaffolding impacts to BMPs)
- Access may be required around the building, defining a haul route may be necessary and denote stabilization needs on this proposed haul route
- Address access to the building as different stages of vertical construction occur. For example, a VTC may work for the duration of the infrastructure construction but as the grading is fine tuned, different measures may need to be implemented to limit access or be more mobile. Controlling access is important during vertical construction, especially when taking access from an impervious surface (i.e. pavement).
- Staging areas change during construction regularly. Therefore, if “con/conex” boxes are to be utilized and if they are to include liquid pollutants, then a redundant BMP measure must be provided
- Site drainage will need to be maintained during vertical construction. Review conditions to ensure that it will continue to work as shown during the grading/utility timeframes.
- Provide redundant BMPs for generators to protect from fuel/hydraulic leaks
- Review the down gradient BMPs within the impervious areas to ensure that conveyances, inlets and outlets are protected appropriately during each phase.
- Areas of disturbance outside of the building envelope shall still require BMPs review the timing/phasing of the project to ensure the appropriate BMPs are implemented as construction continues.
- BMPs for keeping impervious surfaces clean may need to be enhanced or added to as construction continues.
- Review and implement BMP measures to control roof drainage. This becomes a point source and may cause extensive erosion on site.

- Address waste handling procedures for drywall, painters, carpet layers etc.
- Provide BMPs for delivery trucks – i.e. controlled access points, staging areas, delivery areas, parking area.
- Coordination Plan – required if different phases of work are to be done by different general contractors (i. e. road work vs. building façade)
- Details and BMP measures for form oil and form oil lay down area
- Run on modifications
- Interim lot stabilization techniques
- The methods to be used to address the following issues:
 - Irrigation testing
 - Water main testing
 - Building washing
 - Graffiti deterrent application
 - Fire retardant application
 - Fueling
 - Process water (paving rollers, boring equipment, wet saws, etc)

If the design professional is unaware of the types of BMPs that will be necessary during vertical construction, the following statement shall be added to the SWMP narrative and design drawings “A Plan Amendment from the contractor shall be required to be submitted to the engineer of record and City of Aurora Water Engineering Plans Reviewer three (3) business days prior to the Erosion Control Kick-Off Meeting.” This submittal shall provide narrative information and the associated details required for vertical construction BMPs (structural and non-structural) that will be implemented during this phase of construction. Additional cost for mylar changes and review times may be applicable depending on the extent of proposed changes.

4) Materials Handling and Spill Prevention

This section shall describe any procedures and locations for all practices implemented at the site that will be used to minimize impacts from identified potential pollutant sources. BMPs need to address many different pollutant sources that include, but are not limited to exposed storage of construction materials, liquid contaminants, contaminated soils management, fueling procedures, redundant BMPs for any spill or leak sources, and equipment maintenance procedures. Activities involving potential for spills shall have spill prevention and spill response procedures

identified. The information provided may address frequency, seasonal considerations, characteristics of the area and surface type, primary and secondary containment, proximity to drainageways and stormwater facilities.

Spill Response - Cleanup and Removal Procedures

NOTE: IN CASE OF FIRE, EVACUATE ALL PERSONNEL FROM THE IMMEDIATE AREA, RENDER FIRST AID TO ANYONE WHO IS INJURED, AND DIAL 911 IMMEDIATELY. TAKE APPROPRIATE STEPS TO PROTECT HUMAN LIFE AND TO CONTROL FIRES FIRST. SPILL CONTROL IS SECONDARY.

- Upon detection of any spill, the first action to be taken is to ensure personal safety. All possible ignition sources, including running engines, electrical equipment (including cellular telephones, etc.), or other hazards will be immediately turned off or removed from the area. The extent of the spill and the nature of the spilled material will be evaluated to determine if remedial actions could result in any health hazards, escalation of the spill, or further damage that would intensify the problem. If such conditions exist, a designated employee will oversee the area of the spill and the construction SWMP Administrator will be notified immediately.
- The source of the spill will be identified and if possible the flow of pollutants stopped if it can be done safely. However, no one should attend to the source or begin cleanup of the spill until **ALL** emergency priorities (fire, injuries, etc.) have been addressed.

Small Spills

Small spills (usually <5 gallons) consist of minor quantities of gasoline, oil, anti-freeze, or other materials that can be cleaned up by a single employee using readily available materials.

The following procedures should be used for clean-up of small spills:

- a. Ensure personal safety, evaluate the spill, and if possible, stop the flow of pollutants.
- b. Contain the spread of the spill using absorbents, portable berms, sandbags, or other available BMPs.
- c. Spread absorbent materials on the area to soak up as much of the liquid as possible and to minimize infiltration into the soil.
- d. Once the liquids have been absorbed, remove all absorbents from the spill and place the materials in a suitable storage container. On paved areas, wipe any remaining liquids from the surface and place the materials in a storage container. Do not spray

or wash down the area using water. For open soil areas, excavate any contaminated soil as soon as possible and place the soil in a suitable storage container. All materials will then be transported off-site for disposal.

- e. If immediate transfer and storage of the contaminated soil is not practical, excavate and place the contaminated soil on a double thickness sheet of 3-mil or higher polyethylene film. In addition, a small berm should be formed around the outer edges of the soil stockpile, underneath the polyethylene film; to ensure that contaminants are not washed from the site during precipitation events and that materials do not seep through the berm.
- f. Record all significant facts and information about the spill, including the following:
 - Type of pollutant
 - Location
 - Apparent source
 - Estimated volume
 - Time of discovery
 - Actions taken to clean up spill
- g. Notify the SWMP Administrator of the spill and provide the information from Item #6. The SWMP Administrator will then contact the City of Aurora Erosion Control Staff.

Medium to Large Spills

Medium to large spills consist of larger quantities of materials (usually >5 – 25 gallons) that are used on site that cannot be controlled by a single employee. Generally, a number of facility personnel will be needed to control the spill and a response may require the suspension of other facility activities.

The following procedure shall be used for the cleanup of medium to large spills:

- a. Ensure personal safety, evaluate the spill, and if possible, stop the flow of pollutants.
- b. Immediately dispatch a front-end loader or similar equipment to the spill and construct a berm or berms down gradient of the spill to minimize the spread of potential pollutants. On paved surfaces, portable berms, sandbags, booms, or other measures will be used to control the lateral spread of the pollutants.
- c. When the spread of the spill has been laterally contained, contact the SWMP Administrator or designated facility employee and provide them information on the location, type, and amount of spilled material, and a briefing on the extent of the spread and measures undertaken to contain the contaminants.
- d. Depending on the nature of the spill, mobilize additional resources as needed to contain the contaminants.

- e. Cleanup will commence when the lateral spread has been contained and the notification to the SWMP Administrator has been made.
- f. Freestanding liquid will be bailed or pumped into 55-gallon storage drums, steel tanks, or other suitable storage containers. When all the liquid has been removed from the pavement or soil layer, absorbents will be applied to the surface and transferred to the storage containers when they have soaked up as much of the spill as possible.
- g. On paved surfaces, the remaining contaminants will be removed to the extent possible, with rags, sweeping, or similar measures. The area of the spill will not be sprayed or washed down using water. Any contaminant soaked materials will be placed into the storage containers with the other absorbents.
- h. The remaining contaminated soils will be excavated and loaded into a dump truck(s) for disposal off-site at a designated facility. If transport off-site is not immediately available, the remaining soils will be stockpiled on a double thickness sheet of 3-mil or higher polyethylene film. In addition, a small berm will be formed around the outer edges of the soil stockpile, underneath the polyethylene film, to ensure that contaminants are not washed from the site during precipitation and do not seep through the berm.
- i. Record all significant facts and information about the spill, including the following:
 - Type of pollutant
 - Location
 - Apparent source
 - Estimated volume
 - Time of discovery
 - Actions taken to clean up spill
- j. Provide the SWMP Administrator (or designated employee) with the information from Item #9. The SWMP Administrator will then contact the City of Aurora Flow Control Center.

Notifications

Notification to the Colorado Department of Public Health & Environment (CDPHE) and the City of Aurora is required if there is any release or suspected release of any substance, including oil or other substances that spill into or threaten State waters. Unless otherwise noted, notifications are to be made by the SWMP Administrator and only after emergency responses related to the release have been implemented. This will prevent misinformation and assures that notifications are properly conducted.

The notification requirements are as follows:

1. **Spills into/or Threatens State Waters:** Immediate notification is required for releases that occur beneath the surface of the land or impact or threaten waters of the State of threaten the public health and welfare. Notifications that will be made are:
 - a) For any substance, regardless of quantity, contact CDPHE at 1-877-518-5608. State as follows:
 - a. Give your name.
 - b. Give location of spill (name of city).
 - c. Describe the nature of the spill, type of products, and estimate size of spill.
 - d. Describe type of action taken thus far, type of assistance or equipment needed.
 - b) For any quantity of oil or other fluids, call the National Response Center at 1-800-424-8802. State as follows:
 - a. Give your name.
 - b. Give location of spill (name of city and state).
 - c. Describe the nature of the spill, type of product, and estimate size of spill.
 - d. Describe type of action taken thus far, type of assistance or equipment needed.

2. **Reportable Quantity Spill on Land Surface:** Immediate notification is required of a release upon the land surface of an oil in quantity that exceeds 25 gallons, or of a hazardous substance that equals or exceeds 10 pounds or its reportable quantity under Section 101(14) of the Comprehensive Environmental Response, Compensation Liability Act (CERCLA) of 1980 as amended (40 CFR Part 302) and Section 329 (3) of the Emergency Planning and Community Right to Know Act of 1986 (40 CFR Part 355) whichever is less. This requirement does apply at a minimum to the substances listed in Table A below.

TABLE A
Substances Requiring Notification

SUBSTANCE	REPORTABLE QUANTITY
Motor Oil	25 Gallons
Hydraulic Oil	25 Gallons
Gasoline/Diesel Fuel	25 Gallons

The notification procedures to be followed are:

- a) Give your name.
- b) Give location of spill (name of city and state).
- c) Describe nature of the spill, type of product, and estimate size of spill.
- d) Describe type of action taken thus far, type of assistance or equipment needed.

3. Notification is not required for release of oil upon the land surface of 25 gallons or less that will not constitute a threat to public health and welfare, the environmental or a threat of entering the waters of the State.
4. Notification, as required in paragraphs 1 and 2 above, will be made to the CDPHE using the 24-hour telephone number to report environmental spills. All information known about the release at the time of discovery is to be included, such as the time of occurrence, quantity and type of material, location and any corrective or clean-up actions presently being taken. Table B lists these phone numbers.

SPILL RESPONSE CONTACTS

It is the responsibility of the SWMP Administrator to contact the City of Aurora, CDPHE, and/or the National Response Center.

- **The National Response Center** is to be contacted when a release containing a hazardous substance or oil in an amount equal to or in excess of a reportable quantity established under either 40 CFR 110, 4- DFR 117, or 40 CFR 302 occurs during a 24-hour period.
- Notification to the **CDPHE** and **COA** is required if there is any release or suspected release of any material, including oil or hazardous substances that spill into or threaten state waters.

TABLE B

Emergency Notification Contacts

Name/Agency	Number
City of Aurora Fire Department	911
City of Aurora Police Department	911
Ambulance	911
Hospital	911
National Response Center	1-800-424-8802
CDPHE – Report Environmental Spills (24 hrs/day)	1-877-518-5608
City of Aurora – Water Dept Flow Control Center	303-326-8645
City of Aurora – Water Dept Erosion Control Staff	
Colorado Emergency Planning Committee	303-273-1622
Also contact SWMP Administrator and Owner	

REPORTS

The CDPHE and COA require written notification of a spill or discharge of oil or other substance that may cause pollution of the waters of the State of Colorado. A written report must be submitted to the Water Quality Control District (WQCD) and the COA Erosion Control Staff within five days after becoming aware of the spill or discharge.

The CDPHE and COA require a written final report within 15 days for all releases of an oil or hazardous substance that require implementation of a contingency plan. The CDPHE and COA may also require additional reports on the status of the clean up until any required remedial action has been complete.

Written notification of reports must contain at a minimum:

1. Date, time, and duration of the release.
2. Location of the release.
3. Person or persons causing and responsible for the release.
4. Type and amount of oil or substance released.
5. Cause of the release.
6. Environmental damage caused by the release.
7. Actions taken to respond, contain, and clean up the release.
8. Location and method of ultimate disposal of the oil or other fluids.
9. Actions taken to prevent a reoccurrence of the release.
10. Any known or anticipated acute or chronic health risks associated with the release.
11. When appropriate advice regarding medical attention necessary for exposed individuals.

5) Dedicated Concrete or Asphalt Batch Plants

Measures to control stormwater pollution from dedicated concrete batch plants or dedicated asphalt batch plants covered by the SWMP must be identified in the narrative report.

6) Vehicle Tracking Control

The SWMP shall clearly describe and locate all practices implemented at the site to control potential sediment discharges from vehicle tracking. Practices must be implemented for all areas of potential vehicle tracking, and can include: minimizing site access; street sweeping or scraping; tracking pads; graveled parking areas; requiring that vehicles stay on paved areas on-site; wash racks; contractor education; and/or sediment control BMPs, etc

7) Waste Management and Disposal, Including Concrete Washout

The SWMP shall clearly describe the practices implemented at the site to control stormwater pollution from all construction site wastes (liquid and solid), including concrete washout activities and liquid waste washouts, dumpsters, worker trash, and portable toilets.

8) BMP Specifications

BMP Details for installation and maintenance shall be the City of Aurora Standard Details in Appendix D of the *(Rules and Regulations Regarding Stormwater Discharges Associated with Construction Activities (SWMP*

Manual)), latest revision, an approved variance, or an approved plan amendment. All approved variances must be documented in the SWMP. It is understood that not all details in the COA SWMP Manual will be used on this project site, but that all details are available for implementation if unforeseen circumstances warrant their use. Proper procedures must be used to update the SWMP and get approval as documented in the COA SWMP Manual. All physical BMPs require a detail to show installation and maintenance information. If a detail is not available through the manufacturer, then one must be created by the preparer of this SWMP narrative report.

9) Groundwater and Stormwater Dewatering

The SWMP shall clearly describe the practices to be implemented at the site to control stormwater pollution from the dewatering of groundwater or stormwater from excavations, wells, etc. This permit does not authorize dewatering of groundwater. A separate State permit is required for this activity. For any construction dewatering of stormwater from construction areas, describe the BMPs to be used to control additional erosion and transport of sediment.

10) Developer/Builder Specific Practices

The narrative report shall include a description of standard practices regarding stormwater management of the company for whom this SWMP is being developed. The engineer should obtain this information from the Owner/Developer/Builder. At a minimum it shall include:

- Standard practices for construction operations during wet weather conditions and winter weather conditions
- Methods used to obtain compliance from sub-contractors (i.e. fines, education, etc)
- Stormwater education policies for personnel and subcontractors
- Company Standard Operating Procedures as they relate to stormwater management (as appropriate)
- Describe any standard stormwater management construction practices that will be used on the site such as material loading and unloading practices, lot controls, lot access, etc.

Note: Any practices requiring a variance that are discussed here must reference the variance section, and must be requested in the variance section, or they will be considered unapproved and not allowed.

Additional Developer/Builder practices not listed herein shall be submitted 3 days prior to the Erosion Control Kick-Off meeting for review and approval.

SECTION 4 FINAL STABILIZATION AND LONG TERM STORMWATER MANAGEMENT

a) Final Stabilization Measures

The SWMP narrative report shall include a description of the proposed BMPs to be used to achieve final stabilization and long-term stormwater control. Revegetation with seeding and mulching, revegetation with seeding with erosion control blankets, landscaping, green roofs, permeable paving, permanent water quality ponds and permanent outlet protection are examples of final stabilization measures.

b) Seed Mix Information

Provide the name of the City of Aurora standard seed mix(s) that may be appropriate for the site and the soils anticipated for the site and the preferred method(s) for protecting the seed. If the site is not using a COA standard seed mix, then a variance request must be submitted and the preferred seed mix must be provided.

c) Final Stabilization Notes

See Chapter 5 for additional information regarding final stabilization requirements.

1. *Final stabilization is reached when all soil disturbing activities at the site have been completed, and uniform vegetative cover has been established with a density of at least 70% of pre-disturbance levels, or equivalent permanent physical erosion reduction methods have been employed. Vegetative coverage density does not apply to paved areas, walks, buildings, or other hard surface impermeable areas.*
2. *Establishment of a vegetative cover capable of providing the erosion control equivalent to pre-existing conditions at the site can be considered final stabilization (i.e. landscape rocks, mulch, shrubs, etc). This determination will be made by the City of Aurora Water Department Erosion Control Program Staff prior to the close-out of the permit.*

SECTION 5 INSPECTIONS AND MAINTENANCE

The SWMP narrative report shall include a description of procedures to inspect and maintain, in good effective operating condition, the vegetation, erosion, and sediment control BMPs and all other protective measures identified in the plan. The report shall also identify the frequencies of required inspections:

- i. *Prior to Initial Closeout Acceptance, Permittee shall self-inspect the site at least every 7 calendar days and within 24-hours after the end of any precipitation event or snowmelt event that results in runoff and causes surface erosion, except as allowed in item iii below.*
- ii. *Following Initial Closeout Acceptance, and until permit closeout, Permittee shall self-inspect the site at least every 30 calendar days, and within 24-hours after the end of any precipitation event or snowmelt event that results in runoff and causes surface erosion.*

- iii. *Post-Precipitation Event Inspections for Temporarily Idle Sites* – If no construction activities will occur following a storm event, post-storm inspections shall be conducted prior to re-commencing construction activities, but no later than 72 hours following the storm event. The occurrence of any such delayed inspection shall be documented in the inspection record.

SECTION 6 PROBABLE COST FOR INSTALLATION OF BMPS

The SWMP narrative report shall include a standardized probable cost form for furnishing and installing erosion and sediment control BMPs. The standardized probable cost form shall also include costs for required maintenance during the construction phase. The standardized probable cost form will be reviewed by City of Aurora staff and will be used as the basis for determining the amount of fiscal security required for the project. Hard copies of the form to be used for preparing the standardized probable costs for erosion and sediment control BMPs are provided in Appendix F or an Excel spreadsheet may be found on the City of Aurora website under the Water Department. The report shall list the total cost and the Fiscal Security amount, which is equal to the 25% Maintenance Cost amount.

SECTION 7 CALCULATIONS MADE FOR THE DESIGN

The narrative report shall include calculations made in the design of the SWMP, including calculations for sizing of sediment basins, design of erosion control matting, soil retention matting, sediment traps, diversion ditches, temporary stream crossings, weir sizing, or sizing of outlet protection riprap in the appendix with a summary of the results in the report narrative.

SECTION 8 VARIANCE REQUESTS

A listing of variances requested and/or requests for special consideration of innovative BMPs should be provided along with their justification. If appropriate, manufacturer documentation and specifications for requested variances shall be provided in the SWMP narrative report appendices. *If no detail is provided for a physical BMP, the request for variance will automatically be denied.*

Any variance from COA Rules and Regulations Regarding Stormwater Discharges Associated with Construction Activities shall be approved by the City of Aurora. If it is not specifically listed within this section of the narrative, then it shall not be considered an approved variance. There are provisions for Variance requests once construction has begun. See Chapter 3 Section 3.3.3. In such cases the City of Aurora approved variance shall be added to the field maintained SWMP.

[Add additional sections here to meet requirements of other regulations]

REFERENCES

References should include the drainage report, the COA SWMP Manual, and the CDPHE permit at a minimum. Other relevant references may be included.

2.2.2. General SWMP Design and Drawing Requirements

The SWMP Design Drawings must show locations and extents of all BMPs proposed to be installed at a project site. Detailed requirements, design criteria, and guidance on choosing BMPs are provided herein. Drawings shall be submitted on 24" x 36" plan sheets. Unless otherwise indicated herein, SWMP Design Drawings shall follow the basic Civil Construction Plan Requirements listed in Section 2 of the COA Roadway Design and Construction Specifications, and the Plan and Drafting Standards listed in Section 3 of the Roadway Design and Construction Specifications.

There are two types of SWMP design drawings, Initial and Post-Paving. Initial design drawings should address BMPs for initial permit sign off, overlot grading, and utility construction at a minimum. The Post-Paving design drawings should address BMPs associated with fine grading, final stabilization, utility construction, paving, and generally vertical construction. In some cases, vertical construction activities may need to be addressed with the Initial design drawings. Conversely, there are occasions when initial BMPs for permit sign off need to be shown on the Post-Paving design drawings. Therefore, it is the responsibility of the SWMP preparer to know the activities that will be appropriate for the individual site and to address the construction on the design drawings accordingly.

1. Special Project Requirements

- i. *Civil plans and drawings for projects that are NOT required to obtain a Stormwater Quality Discharge Permit: These are projects that are less than an acre and not part of a larger common plan of development but will be getting a Civil Plan approval from the COA. The Civil Plan drawings will need to have the following information provided on their plans and will need to show BMPs on one of the civil plan drawings.*
 1. *Project Area*
 2. *Disturbed Area*
 3. *Receiving Waters*
 4. *Standard SWMP Design Drawing Notes*
- ii. *Temporary batch plants: SWMP designs for temporary batch plants shall include preliminary site plan and final reclamation plans. The SWMP design drawing sheet(s) for final reclamation shall include site clean-up, regrading, and revegetation. The SWMP narrative report shall include the purpose and activities of the plant, the proposed schedule of operation, the proposed*

duration of plant operations, anticipated daily trip generations, and maximum gross vehicle weight of hauling units.

- iii. SWMPs for *underground utility work* shall include BMPs to control the contamination of stormwater runoff from construction erosion and sediment.
- iv. *Small (projects disturbing up to two acres, public trail projects,) and linear utility projects*: initial and post- paving staged BMPs may be shown on a single sheet so long as the phasing of BMPs is clearly identified. The initial BMPs that will be required for permit activation must be clearly identified on the plan. *A system of BMPs is also required for utility construction using trenchless technology.*
- v. *Staged (projects disturbing between two and 40 acres)*: SWMP designs for such projects shall include at least a preliminary (initial) stage, which includes, but is not limited to, the overlot grading of construction and a post-paving stage. Initial stage and post-paving stage SWMP designs shall be shown on separate drawings. The initial BMPs that will be required for permit activation must be clearly identified on the initial plan or maybe shown on an index sheet (if required). All other BMPs must have information regarding phasing of implementation.
- v.i. *Staged and phased (projects disturbing 40 acres or more)*: SWMP designs and construction for such projects shall be divided up into separate construction phases each disturbing less than 40 acres. Staged preliminary (initial) and post paving SWMP designs shall be placed on separate sheets. Multiple phases may be able to be shown on a single sheet depending on site layout and design complexity. *Initial and Post-paving control plans are required.* The initial BMPs that will be required for permit activation must be clearly identified on the initial plan or maybe shown on an index sheet (if required). All other BMPs must have information regarding phasing of implementation. Some sites may need an Interim Stage Plan.

2. Basic Drawing Requirements

All SWMP design drawings shall include the following:

- i. The following signature block shall be included and signed on the first page after the cover.

Project Owner/Developer Signature Block

I have reviewed the information contained within the Stormwater Management Plan and accept responsibility for the requirements set forth.

Permittee/Affiliation (type actual name)

Date

Plan Preparer Signature Block

I acknowledge my responsibility for the preparation of the Stormwater Management Plan.

CO Professional Engineer (type actual name)

Date

ii. Drawing Cover Sheet, including:

- Project name
- Project address
- Owner address, telephone number, fax number, and contact name
- Design firm's name and address, phone number, fax number and contact name
- SWMP Design Drawing Design Engineer's signature block with name, date and PE registration number
- City approved signature block
- Section, township, range
- General Location Map at a scale of 1":1000 feet or 1":2000 feet
- General vicinity of the site location
- Major roadway names
- North arrow and scale
- Required COA SWMP design drawing statement and notes

Standard Statement and Notes for SWMP design drawings "Pursuant to Sections 138-440 and 138-442 of the Aurora Municipal Code, the Permittee shall locate, install, and maintain all Best Management Practices, including, but not limited to, erosion controls, sediment controls, drainage controls, and water quality BMPs as indicated in the approved Stormwater Management Plan (SWMP). The following notes are a requirement and shall be included on the SWMP design drawings developed for this project and submitted for approval by the City. BMP installations shall be installed per the COA Standard Detail in effect at the time of installation or per the approved SWMP design drawing, a COA approved variance, or a COA approved design drawing plan amendment."

1. The Permittee shall be responsible for remediation of any adverse impacts to adjacent waterways, wetlands, storm sewers, storm sewer appurtenances, other properties, etc., resulting from work done as part of this project.

2. Additional erosion and sediment control BMPs may be required during and after construction and shall be executed and completed by the Permittee. The Permittee shall plan, install, and maintain all erosion, and sediment control measures, including drainage and water quality BMPs as indicated on this plan and as necessary to reduce the discharge of pollutants to the maximum extent practicable adverse impacts, erosion and sediment deposition onto paved sections, into storm sewers, storm sewer appurtenances, receiving waters, or off the project site.

3. The Permittee shall take appropriate preventive measures to minimize to the maximum extent practicable dirt and mud from being tracked or deposited onto paved sections via multiple BMPs. Sediment, mud, and construction debris that may be tracked, deposited, or accumulated on paved sections, in the flow lines, private property, and/or public rights-of-way of the City as a result of this construction project shall be cleaned up.

4. Areas reaching substantial completion of grading and topsoil placement operations must be drill seeded and crimp mulched within 14 days of substantial completion of grading and topsoil operations. If an incomplete area is to remain inactive for longer than 30 days, it must be drill seeded and crimp mulched or otherwise landscaped within 14 days from the suspension or completion of land disturbance activities.

5. This approved SWMP design drawing, the associated approved SWMP narrative, a copy of the Stormwater Quality Discharge Permit, and the Rules and Regulations Regarding Stormwater Discharges Associated with Construction Activities Manual shall be kept on site at all times.

6. Accumulated sediment and debris shall be removed from a BMP (maintenance) when the sediment level or debris adversely impacts the functioning of the BMP or as defined within the Rules and Regulations Regarding Stormwater Discharges Associated with Construction Activities Manual, whichever is more restrictive. If maintenance of the BMP does not restore the intended function, then the BMP must be replaced.

7. The discharging of cement, concrete, or mortar from ready mix delivery trucks, pump trucks, batch plants or small mechanical mixers directly onto paved surfaces or disturbed ground having no containment is prohibited. The disposal of any liquid wastes or wash water from any operations such as painting, drywall, or tile installations directly onto paved surfaces or the ground without containment is prohibited. The Permittee shall protect all curb flow lines, adjacent waterways, wetlands, storm sewers, storm sewer appurtenances, other properties, etc., adjacent to any location where pavement cutting operations involving wheel cutting, saw cutting or abrasive water jet cutting are to take place.

8. It shall be the responsibility of the Permittee to resolve construction problems due to changing conditions or design errors they may encounter during the progress of any portion of the work. If conditions in the field require changes and the proposed modifications to the approved plans involve significant changes to the character of the work or to future contiguous public or private improvements, the Contractor, through the engineer of record, shall be responsible to revise plans and submit them to the City of Aurora for approval prior to any further construction related to that portion of the work. Any controls, features or improvements not constructed in accordance with the approved SWMP, City of Aurora standard detail designs, City of Aurora approved variances, or an approved design drawing amendment shall be removed and the controls, features and/or improvements shall be reconstructed.

9. Secondary containment features shall be in place for any bulk fuel storage, mixers, generators, or any other spill or leak source that remains onsite for a period longer than 7 calendar days. A recovery or salvage drum shall be kept on-site for storage of contaminated soils.

10. Straw bales and recycled asphalt or concrete are not acceptable for the construction of BMPs within the City of Aurora and may not be used.

iii. Drawing Index Sheet (only required for projects shown on multiple sheets), including:

- Property lines
- Sedimentation ponds with unique pond names or identifiers
- Sedimentation pond basins delineated and areas of disturbed and non-disturbed labeled
- Phasing with areas including cut and fill volumes and the phasing sequence
- Hydrologic features shown and labeled
- Benchmark
- Major soil stockpiles and borrow areas
- Site access points

- Limits of construction
- Initial BMPs required for permit execution may be shown on the Index Sheet

iv. Initial SWMP design drawing, including:

- Property lines
- Correct scaling (1:50 for single-family residential development and 1:30 for multifamily or commercial development MINIMUM)
- Existing and proposed easements
- Existing contours at one or two-foot contour intervals extending a minimum of 100 feet beyond the property line (dark and dashed)
- Proposed contours screened back and solid line
- Grading phasing including grade tie-ins between phases and any additional BMPs needed between phases
- Over-excavation areas and volumes
- Slope labels for graded slopes and channels/drainages
- Areas of cut and fill
- Existing trees and tree protection measures
- Standard Aurora Parks, Recreation and Open Space tree protection details
- Location of any existing structures or hydrologic features within the mapping limits including 100-year floodplain limits
- Directional flow arrows
- Benchmark used for project
- Limits of construction encompassing all areas of work
- Stream corridors and other resource areas to be preserved and all other areas outside the limits of construction shall be lightly shaded to clearly show area not to be disturbed
- Location stockpiles including topsoil, borrow areas, imported aggregates, and excess material
- Location of storage and staging areas for equipment, fuel, lubricant, chemicals, (and other materials) and waste storage
- Location of borrow or disposal areas
- Location of temporary roads
- Tributary drainage areas labeled for all temporary sediment basins
- Locations for any dedicated asphalt or concrete batch plants
- Location, map symbol, and letter callouts of all initial erosion and sediment control BMPs
- Information to be specified for each BMP, such as type and dimensions, as called for in the notes on the COA Standard BMP Details
- BMPs that may have different timing installations or removals with clear notes
- BMPs specific to the vertical construction , as applicable
- Required COA SWMP design drawing notes, approval blocks, and additional information
- Interim measures and waste handling
- Clearly identify initial BMPs required for permit execution

v. Post-Paving SWMP design drawing, including:

- Final topography (existing topography need not be shown in areas having proposed contours)
- Existing trees and tree protection measures with reference to Aurora Parks, Recreation and Open Space standard details
- Existing Initial BMPs that will remain
- Benchmark used for project
- Correct scaling (1:50 for single-family residential development and 1:30 for multifamily or commercial development MINIMUM)
- Directional flow arrows on all drainage features
- Any Initial BMPs that are to be removed and any resulting disturbed area to be stabilized
- Slope labels for graded slopes, channels/drainages, and streets within the adjacent to the project
- Storm sewer system, both proposed and existing
- Locations for storage areas, trailers, materials, concrete washouts, etc
- BMPs specific to the vertical construction , as applicable
- Adequate notes for individual lot BMPs
- Location of all Final erosion and sediment control BMPs, permanent landscaping, and measures necessary to minimize the movement of sediment off site until permanent vegetation can be established
- Area of buildings, pavement, sod, and permanent landscaping (define types) per approved Landscape Plan, or other improvement plan
- Seeding, mulching, and landscaping everywhere except buildings and pavement areas or provide adequate information/notes for permanent landscape requirements
- Other BMPs considered by the Colorado Professional, licensed Design Engineer to be appropriate for the construction of the site
- BMPs to be removed at the end of construction

3. COA Standard Temporary Construction Stormwater BMP Details

COA BMP Details are pre-reviewed and have been pre-approved for use in the COA, and should not be copied onto plan sheets, unless an applicant proposes a modification to a COA detail. BMP installations shall be installed per the COA Standard Detail in effect at the time of installation or per the approved SWMP design drawing, a COA approved variance, or a COA approved design drawing plan amendment. COA Standard Details for temporary construction stormwater BMPs are provided in Appendix D. The COA Standard BMP Details have been adapted from various sources for use in COA, and include an installation detail drawing, photos, and key installation and maintenance requirements. SWMP design drawings should be prepared using the standard symbols from the COA standard details to indicate proposed locations for various BMPs. If an applicant elects to use alternate BMP design detail(s) in the SWMP, the alternate detail(s) need to be included on the civil plans for review.

“Beta testing” of new/experimental/other BMPs may be allowed on a case-by-case basis in the City of Aurora, provided the engineered design background information is submitted with the

SWMP, and provided that performance is monitored and effective in the field. Such BMPs are subject to the same requirements for regular maintenance and inspection as other BMPs. Experimental BMPs may have to be replaced with others, if the BMPs are found to be ineffective in the field.

The following items may **NOT** be used in SWMP design or field implementation within the COA:

- Crushed and/or recycled concrete
- Milled or recycled asphalt
- Hydro-seeding
- Burlap bags
- Straw bales
- Hydro-mulching (except where approved through a variance)

4. Limits of Construction

Project SWMPs shall be designed such that all proposed construction activities are contained within an established construction boundary. Written approval must be obtained for use of any adjacent property for stockpiling, etc., from the legal owner, and BMPs must be implemented within the adjacent area. Limits of construction shall include all haul routes, stockpiles, borrow areas, bore pits, parking areas (paved or temporarily stabilized), material lay down areas, and active construction areas at a minimum. *Proposed limits of construction shall be shown, and the proposed means of delineating the construction limits in the field shall be indicated on SWMP design drawings.*

5. Work within Drainageways

Elements of work requiring construction in or through drainageways shall either be bored or constructed using a temporary stream diversion. *Locations of project elements proposed to be constructed by boring or through the use of temporary stream diversions, and the proposed BMP(s) for such activities shall be shown on SWMP design drawings.* The Design Engineer shall provide flow volumes for a variety of storms at a minimum. Once the contractor is a part of the project, then the Contractor and the Engineer need to determine the desired flow volume and method of diversion and get it approved through the Water Department Plans Review.

6. Topsoil Stripping and Stockpiling

Topsoil stripping, stockpiling, and re-spreading in areas proposed to be revegetated is mandatory practice within the COA, and shall be called for in all SWMP design drawings.

7. Surface Stabilization

Project SWMPs shall be designed such that areas proposed to be disturbed by construction are stabilized as soon as possible. Surface stabilization does not refer to temporary stockpiles, refer to the Stockpiles section for specific requirements.

- i. Areas reaching substantial completion of grading and topsoil placement operations must be drill seeded and crimp mulched or alternatively stabilized within 14 days of substantial completion of grading and topsoil operations.
- ii. If an incomplete area is to remain inactive for longer than 30 days, it must be drill seeded and crimp mulched or otherwise landscaped within 14 days from the suspension or completion of land disturbance activities.
- iii. BMPs applicable to stabilizing exposed soils within the COA include surface roughening, terracing, seeding and mulching, erosion control blankets, and compost blankets. *An interim stabilization method shall be shown on the drawings for all disturbed areas. Drill seeding and crimp mulching shall be indicated on the drawings for all areas that will not be paved, sodded, landscaped or otherwise stabilized.*
- iv. Surface roughening is expected to be implemented as an interim temporary erosion control measure for areas that are temporarily dormant. Mulching, surface roughening or another temporary stabilization BMP must be used during interim periods when the temporary or permanent seeding cannot be executed, with seeding to follow as soon as conditions allow.

8. Slope Protection

All 4:1 and steeper slopes (excluding temporary stockpiles) must be protected with erosion control blankets. Slopes flatter than 4:1 may also be considered for erosion control blankets based on the following design or site conditions: slope length, hydrologic soil group A or B, tributary to Waters of the State, in proximity to drinking water sources, Parks, Recreation and Open Space properties or in proximity to environmentally sensitive areas. Erosion control blankets must be biodegradable and specified for each specific application and drainage conditions. Permanent non-biodegradable poly matting and jute netting shall not be used for any erosion control blanket application within the COA.

- i. Upslope Perimeters: Stormwater run-on to the project site from adjoining areas must be managed. SWMP design drawings must indicate BMPs to manage clean run-on so that it bypasses areas of disturbance to the extent possible, to reduce erosion, sediment transport and the discharge of sediment off-site.
- ii. Down slope Perimeters: down slope perimeter BMPs apply to the down gradient areas of construction disturbance. Sediment controls shall be located as close to the area of disturbance as possible, on the down slope side, but far enough away to allow construction to occur without damaging the down slope perimeter controls. If the up gradient disturbed drainage area exceeds 1.0 acre, a diversion ditch, diversion berm, or both shall be used to convey runoff to the required sediment basin.

9. Tree and Natural Feature Protection

Existing trees and other natural features shall be protected during construction. *Existing trees, natural features, and proposed protection measures shall be indicated on the SWMP design drawings with reference to Parks, Recreation and Open Space requirements.*

10. Concrete Washout Areas

Concrete washout areas shall be designated and shown on the SWMP design drawings.

Designated concrete washout areas shall be installed in locations near concrete work areas and shall be contained to minimize to the maximum extent practicable transport and spreading. Location of concrete washout areas shall, at a minimum, conform to the following guidelines (or a commercially available, watertight bin shall be required):

- Be at least 400 feet away from drainageways, waterways, and water bodies, or an impermeable polyethylene liner shall be required.
- Be at least 100 feet away from a storm sewer inlet or additional redundant BMPs may be required
- Be at least 1000 feet away from any wells or surface drinking water source.
- Not be located in a natural draw or drainage swale.
- Not be located in areas of highly permeable soils, i.e., gravels and sands, or an impermeable polyethylene liner shall be required.
- Not be located in areas where the existing grade and vegetation is to be preserved.
- Be located such that if a failure or overtopping occurs, flow would go to flat or depressed vegetated areas, away from drainage areas, conveyances, and paved surfaces.
- Not be located near an existing or proposed outlet, or culvert.

11. Waste Control and Disposal

Within the City of Aurora, without full containment, the discharge or disposal of any waste products or water contaminated by waste products to inlets, curb flow lines, adjacent waterways, paved sections, wetlands, disturbed ground, other properties, etc., is prohibited. In this context, waste products include but are not limited to products from activities such as: painting, sheet rock installation, tiling, grouting, masonry, cleaning, cutting or other operations that include the use of any potential pollutant source products.

The SWMP shall identify materials and wastes on the site and activities that could contribute pollutants to runoff.

- Secondary containment features shall be indicated for any bulk fuel storage that remains onsite for a period longer than 7 calendar days.
- Containment measures shall be indicated for generators, pumps, mixers and other non-electrical powered equipment that are to be stationed for longer than 24-hours.

- Control measures shall be indicated to manage any wastes generated during saw cutting operations, including slurry. All anticipated liquid and solid wastes require adequate containment, storage and disposal.

12. Sanitary Facilities

Sanitary facilities shall be located away from drainageways, sidewalks, at least three feet back from curb flowlines, off of paved surfaces (when possible) and secured to prevent the units from tipping. Sanitary facilities shall generally be placed behind sidewalks. Sanitary facilities shall not be placed or temporarily located within 50 feet of any storm sewer inlet. *Sanitary facility locations shall be identified on the SWMP design drawings.*

13. Vehicle Tracking Control

Vehicle Tracking Control (VTC) shall be used to adequately and proactively control dirt tracking onto paved sections, including paved areas located within the interior of the construction site, by controlling the work, site access, and public traffic onto disturbed areas. *At least one VTC pad shall be provided and shown on the SWMP design drawings, at an entrance/exit point where a paved section transitions onto disturbed areas.* Additional access provisions may be necessary for fire truck access for life safety purposes.

14. Lot Perimeter Controls

Perimeter Controls, or Individual Lot Controls, shall be indicated on the SWMP design drawings for residential and commercial building construction, to assist in containing the site and controlling the offsite migration of soils and other pollutants that may be present on-site. These features shall be installed on the down gradient boundaries of all residential and commercial construction sites. Where sidewalks are present, installations may be required on the property side of the sidewalk and at the curb. These temporary boundaries may consist of sediment control logs, silt fencing, access controls, downstream curb socks, erosion control blanket, surface roughening, or other linear BMPs that the COA determines to be effective and acceptable for perimeter control applications.

15. Stockpiling

The City recognizes the need for different types of earth material to be stockpiled on a job site. All stockpiles require erosion and sediment control. COA Code Sec. 114-31(b) prohibits the placement of landscaping materials, earth material, stockpiles, or dirt from grading or excavation activities on paved surfaces or roadways. Topsoil stockpiles must be located in such a manner that they may be adequately protected and not impact water quality leaving the site. *Proposed stockpile locations consisting of topsoil, soil, and other materials shall be shown on the SWMP design drawings. Adequate "footprints" for topsoil stockpiles shall be shown on the SWMP design drawing. Stockpile slopes shall be no steeper than 3 (horizontal) to 1 (vertical).* Stockpiles shall:

- Be located within the limits of construction.
- Have adequate access on the upstream side
- Not be located adjacent to a waterway (at least 100 feet from the banks of a drainageway).
- If a stockpile, or a portion of a stockpile, is to remain undisturbed for 45 days, then permanent stabilization measures must be applied
- If a stockpile will intermittently be utilized during a project by adding or removing material, then at least one perimeter control BMP must be applied prior to stockpile creation and at least one additional BMP must be applied within 10 days of creation of a stockpile. The intent is to provide redundancy of BMPs for stockpiles within a small area surrounding the stockpile (i.e. within a lot or pad site or as reasonable for large stockpiles). The perimeter control may be an existing perimeter control such as silt fence, sediment control log, diversion ditch/earthen berm, etc, while the additional BMP measure must be one of the following options:
 1. Sediment barriers such as diversion ditches/earthen berms, silt fence, silt fence reinforced, sediment control logs, rock socks, or other approved sediment barriers on all down slope sides of the stockpile. Such BMPs must be utilized and maintained for the life of the stockpile.
 2. Be temporarily stabilized within 10 days of creation of the stockpile. Temporary stabilization may include, but is not limited to, surface roughening, seeding, and/or mulching.

16. Dewatering Operations

For planned dewatering, COA requires that applicants provide a copy of their dewatering plan to the COA Water Department Erosion Control Program Staff prior to beginning dewatering operations. Only dewatering of stormwater is allowed under the City's Stormwater Quality Discharge Permit. All other dewater operations require an additional permit from the Colorado Department of Public Health and Environment – Water Quality Control Division. All dewatering operations must be effective and shall be accomplished such that no adverse or erosive effects occur or it may be subject to enforcement action.

17. Sediment Control Logs and Silt Fences

SWMP designs which include sediment control logs (SCL), reinforced silt fences (SFR), and silt fences (SF) shall indicate these features being installed parallel to elevation contours, rather than across contours. In addition, COA does not allow SCL, SFR and SF to be used as check dams across swales or drainageways. Reinforced silt fences are generally used when a construction activity is adjacent to a drainageway or other highly sensitive area. *Proposed locations of sediment control logs, reinforced silt fences, and silt fences must be shown on the SWMP design drawings.*

18. Temporary Stream Crossings

Temporary Stream Crossings (TSC) should include culverts sized appropriately for bank full flow. *Sizing calculations for TSC culverts must be included the SWMP narrative report. SWMP design*

drawings shall reflect the location, length, height, overtopping depth, quantity and diameter of culverts. COA does not allow ford crossings (i.e. riprap with minimal grading and no culvert).

19. Temporary Roads

The location of temporary roads designated for use during the construction period must be shown on the SWMP design drawings.

20. Temporary Slope Drains

Temporary slope drains (TSD) are to be used to convey runoff down a channel bank or slope to the bottom of a drainageway. A TSD may consist of a pipe, plastic, or riprap. *Sizing calculations for TSD must be provided in SWMP narrative reports. SWMP design drawings shall reflect the type, size, location, length, dimensions, and rip-rap size for TSD.*

21. Diversion Channels

Diversion channels (DC) are constructed to convey stream flow around in-stream or across-stream construction. *SWMP narrative reports for projects using DC shall include calculations used to determine the appropriate size and dimensions of the feature. SWMP design drawings for projects using DC shall include provisions for temporary stabilization of the impacted slopes, inlet, outlet, and return channel, materials, and the size and dimensions of DC feature(s) (side slopes, depth, grades, sizing and piping schedule).*

22. Temporary Sediment Basin Requirements

Temporary sediment basins (TSB) are required whenever construction activities disturb two or more acres in the COA. This includes soil stockpiles that cover two acres or more of area. The following exceptions apply:

1. Long linear projects will be required to provide a TSB if 2 acres or more of disturbed tributary area drains to a single discharge point.
2. The over-excavated area of a project may temporarily be used as a temporary retention TSB for areas tributary to it.

Temporary sediment basins shall be designed in accordance with UDFCD criteria. *Design calculations for temporary sediment basins must be provided in SWMP narrative reports. SWMP design drawings must show all proposed temporary sediment basins with plan-view basin grading, dimensions, tributary drainage areas, and disturbed areas.*

a. Use of an Existing Pond

Detention and retention ponds may be adapted to function as temporary sediment basins during construction.

1. SWMP design drawings for projects with detention and retention ponds shall reflect protection(s) to prevent untreated, sediment-laden stormwater from flowing straight through these facilities. Until final landscaping occurs and the facility is functioning as a permanent water quality pond, the permanent outlet structures for such facilities should either be outfitted with a perforated riser pipe in place of an orifice plate, or have a temporary plate installed that is equivalent to the riser pipe. The outlet structure should also be protected with rock wattles or a berm (constructed of gravel or other fine filter medium) but the outlet holes shall not be covered by such media.

2. Existing and proposed detention or retention ponds that have or will have permanent water quality outlet structures require over excavation if they are proposed to be used as temporary sediment basins during construction. Regional detention and water quality basins cannot be used as temporary sedimentation basins. The over excavation at the outlet structure shall be calculated with the following formula:

$$\frac{\text{Proposed Temporary Sediment Basin Design Volume}}{\text{Existing Facility Water Quality Capture Volume}} = \text{Required Over Excavation Volume}$$

3. The original pond certification shall be considered null and void once the pond is modified for use as a TSB. Once the pond is returned to its original state and has achieved final stabilization is shall be re-certified per Public Works requirements.

23. Temporary Sediment Traps

Temporary sediment traps are for small tributary drainage areas of less than 2 acres. They are generally used as a controlled outlet for diversion ditches that are along a perimeter of some sort (i.e. construction limits, phase limits, toe of slope, etc).

24. Inlet and Outfall Protection

SWMP designs shall include inlet protection for all existing and proposed storm sewer inlets on a site. *SWMP design drawings shall indicate inlet protection for all inlets, and whether area, sump, or on-grade inlet protection is to be used in each location.* Curb-sock inlet protection is intended to trap sediment upstream of an inlet at an on-grade location without causing or allowing any bypass of flow around the inlet. Sump and area inlet protection are also designed to maintain inlet capacity after runoff flows over the wire mesh wrapped rock. COA does not allow the use of any recycled concrete rubble materials for inlet protection.

25. Managing Site Drainage

SWMP designs must reflect adequate drainage controls to appropriately manage stormwater runoff, run-on and site drainage. SWMP designs must include control features to divert, convey, and detain flows as needed to manage site drainage. Run-on controls should include designed release points to direct flows down existing or overall planned drainage pathways and should be designed to not cause erosion or damage. Design of all interim and permanent stormwater management systems must include provision for adequate drainage controls during overflow conditions to minimize the potential for flooding.

26. Diversion Ditches and Berms

Diversion ditches are used to convey flow to an outlet such as a sediment trap, a sedimentation basin or a temporary slope drain. They are also used to route run on flows around construction work areas. Diversion ditches should not end at a silt fence or check dam or other sediment barrier that will retard flow without a settling basin area. Compacted earthen berms are to be utilized as a sediment barrier for very small tributary areas. Spot elevations should be included on the plan to show that the diversion ditches will be constructed to flow as intended. Diversion ditches need to change in elevation as grading activities progress, which may require cutting in the ditch daily.

27. Tackifiers

Use of a tackifier requires a Variance. Organic tackifiers may be utilized when looking at temporary stabilization or as dust control measures. Organic tackifiers cover a wide range of materials – vegetable based, corn starch, psyllium husks. Polyacrylamides (PAM) shall not be utilized as temporary stabilization measure or dust control. Tackifiers may not be utilized in lieu of crimping procedures required during permanent stabilization measures.

- i. Tackifiers shall be reviewed and chosen with slope, soil type, and type of use in mind. Information shall be provided within the SWMP narrative and manufacturer information in regards to materials, application rates etc shall be provided in an appendix.
- ii. Use of a tackifier requires a Variance. Organic tackifiers may be utilized when looking at temporary stabilization or as dust control measures. Organic tackifiers cover a wide range of materials – vegetable based, corn starch, psyllium husks. Polyacrylamides (PAM) shall not be utilized as temporary stabilization measure or dust control. Tackifiers may not be utilized in lieu of crimping procedures required during permanent stabilization measures.

28. Additional Resources/References Available

Applicants are also referred to the CDPHE-WQCD SWMP for general guidance in designing a SWMP suitable for the development or project of interest. In addition, applicants may find general guidance on SWMP design and BMP selection in various references, including but not limited to the following.

- Douglas County, Colorado: Erosion, Grading, and Sediment Control Manual (<http://www.douglas.co.us/publicworks/engineering/GESC.html>)
- Urban Drainage and Flood Control District: Urban Storm Drainage Criteria Manual, Volume 3 (http://www.udfcd.org/downloads/down_critmanual.htm)
- City and County of Denver: Storm Drainage Design and Technical Criteria (<http://www.denvergov.org/Portals/487/documents/Storm%20Drainage%20Design%20and%20Technical%20Criteria%20Manual%20012006.pdf>)
- Arapahoe County, Colorado: Grading, Erosion, and Sediment Control Manual (<http://www.co.arapahoe.co.us/Departments/PW/Engineering/GESC.asp>)

2.2.3 Variances

1. Applicants and Permittees may request a variance from any specified BMP within these regulations. Variance requests must be done in accordance with the following:
 - i. Prior to Approval of Storm Water Management Plan (including design drawings and narrative report) variances are to be requested within the Variance Section of the narrative report.
 - a. The variance request shall be incorporated into the Civil Plans submittal with all alternative BMP Details included on the plans.
 - b. Aurora Water will respond to the variance request with the standard Plan and Report Review Process.
 - ii. After Storm Water Management Plan Approval (e.g., field variances) See Chapter 3.
 - iii. COA decisions regarding variance requests may be appealed in accordance with Chapter 2, Section 2.2.4, below.

2.2.4 Appeals

1. Applicants may appeal City of Aurora plans review decisions regarding denied variance requests.
2. Appeals must be submitted in accordance with the following:
 - i. Appeals must be submitted in writing to Aurora Water to the attention of the Environmental Permitting & Compliance Manager within three (3) business days of receiving plans review or SWMP comments or within three (3) business days of receiving a denied variance request. Appeal requests not submitted (e.g., postmarked or submitted electronically) within the three (3) business day limit will not be reviewed and will be considered a denied appeal.

- ii. Appeal requests will be reviewed by a committee consisting of Aurora Water’s Manager of Engineering, Environmental Permitting & Compliance Manager and a representative of the City Attorney’s office. The City’s Parks, Recreation and Open Space and Public Works Departments will be consulted as appropriate.
- iii. The committee will make a recommendation to the Director of Aurora Water for a final decision on the appeal.
- iv. The City of Aurora Water Department will respond to the appeal within four (4) business days of receipt of the appeal

2.3 Permanent BMPs

Permanent stormwater BMPs are also required for new development and redevelopment projects disturbing an acre or more within the City of Aurora. Permanent stormwater BMPs are designed to protect the quality of stormwater discharges in the long run, after construction has ended. These permanent BMPs protect stormwater from sediment and other contaminants over time. Type(s) and location(s) of permanent BMPs must be indicated on the civil plans during the design phase. Reference the latest editions of the *COA Storm Drainage Design and Technical Criteria* and the *Urban Drainage and Flood Control District (UDFCD) Urban Storm Drainage Criteria Manual (USDCM)* for permanent BMP requirements and design information. Permanent water quality and detention ponds require an Operations and Maintenance Manual. Refer to the above reference manual and the City of Aurora Storm Drainage Design & Technical Criteria Manual.

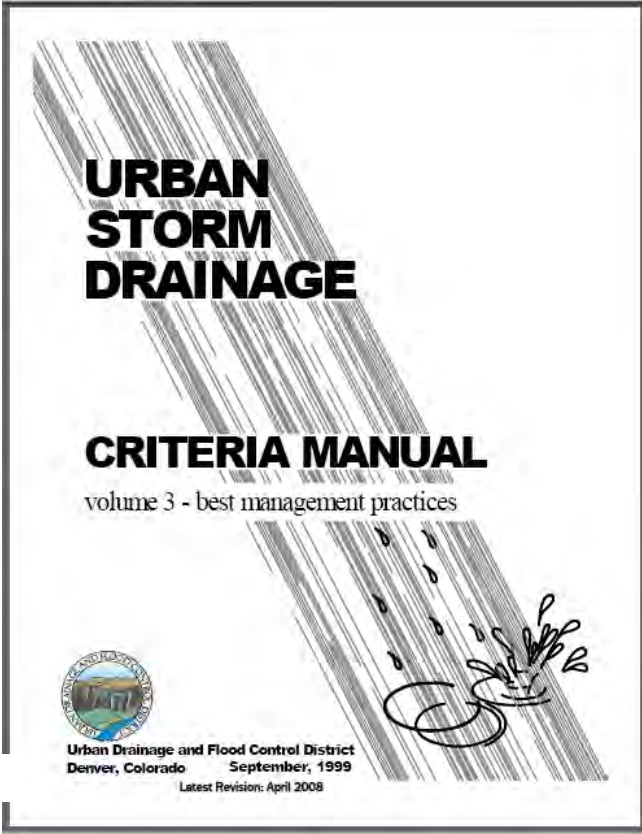

Chapter 3: Construction Phase Requirements

During the construction phase, Permittees are responsible for ensuring that all the BMPs are continuously implemented and monitored to ensure effective operation and maintenance of them during the current phase of construction as described in the submitted (or revised) SWMP, and that the SWMP is kept up-to-date indicating changes in construction activities and BMPs in use. SWMP documents shall be updated with the date changes were made and initialed by a site representative, preferably the site's SWMP administrator. Time of day may be necessary if additional design is required. Changes in the means and methods to construct the site may cause the Permittee to submit revisions to Water Engineering – Plans Review to ensure compliance. All temporary erosion and sediment control facilities, and all permanent facilities intended to control erosion from any construction earth disturbance operations, must be installed and pass an inspection by the appropriate City of Aurora Water Department Erosion Control supervisor and staff before any earth disturbance operations (including grubbing) begin. During construction, Permittees are responsible for conducting and documenting regular inspections and routine maintenance of all the BMPs, until final permit closeout. Permittee paperwork including SWMP updates, seven (7) day inspections and maintenance logs will be reviewed by City personnel on a routine basis.

3.1 Pre-Construction: SWMP Administrator Designation and Training

The Permittee is responsible for BMP implementation, inspection, and maintenance throughout the life of a project, from permit issuance through final permit closeout. A SWMP Administrator must be designated for all permitted construction projects within the City of Aurora. The SWMP Administrator's name will be indicated on the permit application, along with contact information, and how he or she will be most effectively contacted by the City in case of emergency. Permittees do not necessarily need to provide separate SWMP Administrators for every construction site, but SWMP Administrators' other responsibilities must allow the designated SWMP Administrator the ability to respond to the site in a timely fashion (within 2 to 4 hours, but immediately in case of pollutants release off-site). One or two SWMP Administrator alternates shall also be designated in case the designated SWMP Administrator is unavailable or unable to fulfill his/her responsibilities.

3.1.1 Qualifications of SWMP Administrators (and alternates)

SWMP Administrators shall be knowledgeable in the principles and practices of erosion and sediment, pollutant and water quality controls, and utilizing Best Management Practices to implement these controls and shall possess the skills to assess conditions at the construction site that could impact stormwater quality. SWMP Administrators and alternate(s) shall be

designated by the Permittee, and have the experience and background necessary to: 1) read the SWMP (narrative and design drawings), project design drawings, specifications, and this Manual, understand their content and the processes necessary to complete the tasks, and 2) effectively communicate with COA Water Department Erosion Control supervisor and staff in regards to erosion and sediment control measures. For successful construction phase compliance, it is recommended that Permittees assign their SWMP Administrators the authority and resources to install and maintain BMPs on the site throughout construction.

3.1.2 Staff Training on SWMP

Designated SWMP administrators need to get acquainted with the SWMP before the start of construction. SWMP administrators need to be able to: 1) recognize BMP maintenance needs and failures and 2) be able to ensure maintenance is conducted and failures are repaired on an ongoing basis.

A SWMP administrator may need training course(s) to be able to fulfill his/her duties on site. It is in Permittees' best interest to ensure SWMP administrators are well qualified and trained. Various training classes are offered by various entities such as the Associated General Contractors of America, Rocky Mountain Education Center at the Red Rocks Community College, the Colorado Contractors Association, and Home Builders Association. The City of Aurora does not specifically endorse any of the classes, but believes ongoing education and training is an important aspect of ensuring proper site maintenance.

3.1.3 Current Construction Phase Compliance Assistance Available to Permittees and Others by City of Aurora/Aurora Water and Others

Aurora offers the following types of compliance assistance training to interested parties free of charge. Interested parties should contact Aurora to schedule desired compliance assistance training session(s). Interested parties may request to review training materials in advance.

- On-Site Compliance Assistance Training – COA Erosion Control Inspection Supervisor leads the COA Erosion Control staff in a meeting with a contractor and trade partners (on project site) to review regulatory requirements, erosion, sediment and pollutant concerns during construction, answer questions and provide hand-outs.
- Corporate Compliance Assistance Training – COA Erosion Control Inspections Supervisor leads COA Erosion Control staff in a meeting and power point presentation (approximately 1 hour) with a selected builder or contractor at their corporate offices. This presentation is more detailed and more visual than the on-site meeting.
- Site Walk-Through – COA Erosion Control Staff (Supervisor and/or Inspector) walk the site with responsible site personnel, to help them understand the COA inspection process and violation identification.

3.1.4 General Construction Erosion Control Requirements Set Forth by COA

1. Limits of construction must be identified in the field. If the project is to be phased the limits of construction can be identified for that phase and not for the entire project. The permittee will be required to contact COA Erosion Control Staff 72 hours prior to beginning the next phase of construction.
2. Earth disturbances shall be conducted in such a manner as to effectively control runoff volumes, reduce accelerated soil erosion, and reduce sediment movement and deposition offsite to pre-disturbance levels.
3. As much vegetation as possible should be left on the site to act as buffer for potential stormwater runoff.
4. Trees and sensitive areas on the site should be protected during construction activities.
5. Earth disturbances shall be conducted in such a manner so that the total amount of soil exposed at any given time does not exceed 40 acres. Projects whose total disturbance must exceed 40 acres shall be phased such that no more than 40 acres is disturbed at any one time. The duration of exposure of disturbed land shall be kept as short as possible. Additional grading phases may not be started without appropriate stabilization, COA inspection, and COA sign off on the previous phase.
6. Sites that will export 500 cy of material shall be required to provide proof of permits for the exporting of this material. If the exported material is going to be received by a site that is within Aurora corporate boundaries, a separate permit for the site accepting the exported material, or an amendment to the Permittee's existing permit to accept responsibility for this area is required. If the exported material is going to be taken out of Aurora Corporate Boundaries, proof of permits for the receiving site within that local jurisdiction shall also be required (see Chapter 2 for further requirements).

3.2 Erosion Control Kick-Off Meeting, Initial Plan Amendments Initial Site Inspection, Construction

During construction, Permittees are required to implement and continuously maintain the BMPs shown on the approved or revised SWMP to ensure compliance.

3.2.1 Erosion Control Kick-Off Meeting

Once the permit is obtained, the Permittee shall contact the Erosion Control Inspection Supervisor to inquire if an Erosion Control Kick-Off Meeting shall be held for this site. The City of Aurora recognizes that the professional engineer preparing the SWMP may not be familiar with every nuance of construction. To ensure adequacy and practicality of the SWMP, an Erosion Control Kick-Off Meeting is recommended. This meeting may involve COA Water Department Erosion Control Staff, Engineer of Record, Developer/Owner, SWMP Administrator, plans reviewer, site superintendent and excavator, any other parties that the Permittee feels are relevant to the permit requirements are welcome to attend.

The approved SWMP will be reviewed and discussed during the meeting to determine if the builder, developer, and/or site superintendent have any modifications they would like to request. The engineer of record may elect to approve the requested modifications, suggest alternate BMPs or inform all parties that the requested modifications need further review. Modifications may be documented in several different ways: revisions may be made to the SWMP narrative, plan revisions may be required per City standards or SWMP updates. If any of these parties are not in attendance at the Erosion Control Kick-Off Meeting the requested modifications will need to be sent to the appropriate parties for review and approval prior to proceeding with implementing the requested changes. All SWMP modifications require approval by the appropriate COA personnel. The Permittee may coordinate the initial inspection at this time or may elect to contact the appropriate COA Water Department Erosion Control representative 72 hours in advance of their anticipated start of construction.

A supplier's list shall be provided in an appendix of the SWMP to ensure that the COA Rules and Regulations requirements for BMP implementation are being met (i.e. inlet protection gauge of wire, silt fence tensile strength, etc.) At a minimum, this list shall be provided to COA during the Erosion Control Kick-Off Meeting. If one is not held, the supplier list shall be provided at the Initial Inspection to the appropriate COA Erosion Control Staff.

3.2.2 Initial Plan Amendment

The permittee may be required to submit a plan amendment to the Colorado licensed engineer who prepared the plans and to COA Water Engineering- Plans Review three (3) business days prior to the Erosion Control Kick-Off Meeting for review and approval if this was noted as a requirement either in the SWMP narrative or on the SWMP design drawings.

Items discussed during the Erosion Control Kick-Off Meeting may require review and approval from the Colorado licensed engineer that prepared the plans. These will be routed through the appropriate Plans Review staff for review and approval also.

3.2.3 Initial Inspection and Permit Execution

The permittee is responsible for implementing the initial BMPs. After the initial BMPs and tree protection measures are installed, the Permittee calls for an initial inspection with the appropriate COA Water Department Erosion Control Staff, who will identify if the BMPs were installed correctly in accordance with the SWMP (installation shall be per COA details unless other details were included, reviewed, and approved as part of the SWMP, during civil plans review), or if any modifications are needed. If the site involves facilities (existing and future) to be managed by the Parks, Recreation and Open Space Department (PROS), Capital Projects Division (CPD) or Public Works (PW) a representative from the respective departments should participate in the initial site inspection.

Only the work involved in the installation of initial BMPs shown within the SWMP shall be executed prior to the initial COA site inspection. If there are deficient items noted during the initial site inspection, the Permittee shall make the necessary corrections and reschedule an inspection. Re-inspection shall be required to verify these modifications have been implemented and execute the Permit. No earthwork activities, including grubbing, may begin until the City of Aurora Water Department Erosion Control Staff has executed the permit. Once the BMPs are installed per detail, the permit is signed, and construction may begin. For guidance on correct installation and maintenance of BMPs, refer to the City of Aurora Details in the Appendix of this manual.

Permittees are required to produce the COA SWQ Permit (SWQP), *Stormwater Discharges Associated with Construction Activity* Permit issued by the Colorado Department of Public Health and Environment-Water Quality Control Division (CDPHE-WQCD, also referred to as ‘the Division’ or ‘the State’), if one is required for the project, and a copy of these Rules and Regulations, current revision, during the initial COA inspection. **If the Permittee obtains a *Stormwater Discharges Associated with Construction Activity* Permit issued by the Colorado Department of Public Health and Environment-Water Quality Control Division a City of Aurora Stormwater Quality Permit is also required for the site.** Additional permits may be required to be shown to COA Personnel during the initial inspection, these may include but are not limited to a 404 permit or a Dewatering Permit issued by CDPHE-WQCD.

If the Colorado licensed design engineer is informed during the review process that a City of Aurora Stormwater Quality Permit is not required based on project requirements and the Owner/Developer chooses to obtain a *Stormwater Discharges Associated with Construction Activity* Permit issued by the Colorado Department of Public Health and Environment-Water Quality Control Division, this Permittee shall be required to prepare the necessary documents

per the Division's requirements. The permittee shall be required to follow the appropriate protocols required per the Division's requirements. The City may elect to inform the Owner/Developer that they are operating under these requirements and are responsible to implement the Division's program fully.

3.3 Construction

During construction, Permittees are required to implement and maintain the BMPs shown on the approved or revised SWMP to ensure compliance.

3.3.1 On-Site Documentation

Permittees are required to keep their **COA Stormwater Quality Discharge Permit for Construction Activities**, approved SWMP (narrative and design drawings), Permittee's inspection records and maintenance logs on-site. If the documents are not to be kept on site, approval from the City of Aurora shall be required; additional approvals from CDPHE-WQCD may be required. Additional requirements may be placed on the Permittee if the documents are not to be kept on site, i.e. a sign shall be posted indicating the location of the SWMP and information of who to contact for more information. This sign shall be posted on the job site trailer or at the site's entrance.

A supplier's list of the erosion control measures to be provided to the site shall be placed in an appendix of the SWMP to ensure that the COA Rules and Regulations requirements for BMP implementation are being met (i.e. inlet protection gauge of wire, silt fence tensile strength, etc.)

The City of Aurora's Rules and Regulations Regarding Stormwater Discharges Associated with Construction Activities includes the approved details to be implemented on site. Any additional details shall be provided in the SWMP (narrative and design drawings) and approved through the Plans Review process. If field changes are needed and deviate from the approved details, these details shall be incorporated into the SWMP via Variance request (see Section 3.3.3)

In addition, any other project permit such as (but not limited to) the CDPHE-WQCD Construction Stormwater Discharge Permit, the State of Colorado Stormwater and/or Construction Dewatering Discharge Permits and 404 Permit(s) shall be prominently displayed on the project site at all times.

These documents shall be reviewed by City of Aurora Erosion Control Staff on a routine basis.

3.3.2. BMP Maintenance and Inspection

Throughout the life of the permit, erosion and sediment control practices and other protective measures identified in the SWMP shall be maintained in continuous, effective operating condition and in accordance with good engineering, hydrologic and pollution control practices. Therefore, Permittees' routine site inspections must address maintenance of BMPs that are found to no longer function as required and designed, as well as preventive maintenance to proactively ensure continued effective operation. Permittees are required to make routine inspections of all BMPs at a minimum of every seven (7) calendar days and within 24-hours after the end of a precipitation event resulting in runoff, and following snowmelt events. If no construction activities will occur following a storm event, post-storm inspections shall be conducted prior to re-commencing construction activities, but no later than 72 hours following the storm event. The occurrence of any such delayed inspection shall be documented in the inspection record. A suggested self-inspection check-list is available in the EPA Stormwater Pollution Prevention Plan (SWPPP) guide (http://www.epa.gov/npdes/pubs/sw_swppp_guide.pdf) on page 35 of the EPA link. This document is a recommended guidance for Permittees to follow when conducting routine self-inspections. Performing routine self-inspections following this guidance will help Permittees to be prepared for announced or unannounced inspections by COA, CDPHE-WQCD, or others.

BMPs found to have failed during Permittees' routine self-inspections, or found to have the potential to fail without maintenance or modifications, must be addressed as soon as possible, immediately in most cases, to reduce the discharge of pollutants with stormwater.

Permittees should adapt good housekeeping measures to ensure that their sites stay in compliance with the Permit. For example, such measures may include removing sediment caused by accelerated soil erosion from runoff water before it leaves the site of the earth disturbance. Streets within and immediately surrounding a construction site shall be cleaned of earth material. Scraped or swept material shall not be deposited in storm sewers.

3.3.3 Management of the SWMP

The SWMP (narrative and design drawings) must be kept updated under the supervision of the SWMP administrator and/or alternates to reflect any field changes and locations of the BMPs in use, related to daily construction site, activities or phasing changes.

The City recognizes that construction is a dynamic condition and not all BMPs may be effective as shown on the approved SWMP during all phases of construction. SWMP changes may be undertaken by the Permittee during the construction period; however, certain amendments/variances, as noted below, must be reviewed and approved by the specified City of Aurora Water personnel. While any staff member may be contacted to discuss plan modifications, the Permittee will be referred to the appropriate staff member depending on the type of modification requested. The information needs to be submitted by the Permittee with concurrence from the Owner/Developer. These requests shall answer who, what, when,

where, why and how; along with the project information, maintenance, timing and the appropriate manufacturer's cut sheets. The variance/modification request shall be submitted via email to the appropriate staff person.

SWMP updates that require engineering calculations and design information shall be reviewed and approved by the Aurora Water Engineering Plans Review staff. These revisions shall be submitted by the Colorado licensed professional engineer plan preparer. These changes include:

- Revisions to grading and drainage
- Revisions to either removing temporary sediment basins/traps or reducing their size due to other BMP implementation.
- Addition of sediment basins.
- Diversions in a water way
- Removal of grading, drainage or hydraulic features not previously phased in the approved SWMP
- Exporting 500 cy of material to another site within Aurora – see Chapter 2 for additional requirements.
- Relocation of diversion ditches to different basins
- Any other modifications to the SWMP that potentially affect the health, safety and welfare of the public in the opinion of the Erosion Control Inspection Supervisor.

The following updates shall be reviewed and approved by the Erosion Control Inspection Supervisor:

- Deviations from the approved details provided in the Rules and Regulations, current edition, which is required to be on site during construction, thus requiring a variance.
- Use of different materials for BMPs from the approved details provided in the Manual
- Implementation of sediment traps
- Relocation of temporary drainage features if additional BMPs need to be implemented to continue construction (i.e. crane route implementation). These features must be maintained in the general area and not impact the intent of the plans. These changes may be referred back to the Plans Review Engineer for further review and approval.
- Removal of previously approved BMPs not previously phased in the approved SWMP

These items may also be subject to review by Water Engineering on a case by case basis.

SWMP updates not previously mentioned above can be reviewed and approved by the Erosion Control Staff and subsequently added to the living document. Inspectors will document updates to the SWMP within their reports if the Permittee requests changes. These changes may include but are not limited to:

- Implementation of additional approved BMPs per the Rules and Regulations, current edition or previously approved BMPs in the site's SWMP
- Relocation of approved BMPs per the Rules and Regulations, current edition, or previously approved BMPs in the site's SWMP

- Adjustment of BMPs during a phase of construction
- BMP substitution with BMPs per the Rules and Regulations, current edition or previously approved BMPs in the site's SWMP
- Any modifications requested by the Permittee may be referred back to the Erosion Control Inspection Supervisor for review and approval by the COA Water Department Erosion Control Staff.

The updated SWMP (narrative and design drawings) are to be located on site at all times. Permittees' routine self-inspections shall be documented using forms, log books, and/or other documentation as Permittees determine to be necessary. Permittees are responsible for maintaining on-site records of BMP installation logs and BMP maintenance activities, self-inspection documentation, SWMP revisions, SWQP permit, all other relevant permits. Written documentation of regular inspections, noted deficiencies and corrective actions taken is required to be retained during the life of the permit and for a period of three (3) years after final stabilization is achieved and permit is closed-out.

3.3.4 Special Development Requirements

Utility Installations:

All utility line construction shall comply with the following:

- All public or dry utility work within a COA right-of-way or utility easement shall be required to obtain a *COA Public Improvement Permit* and must be licensed to work in the COA right-of way.
- Provide adequate erosion and sediment control.
- For work within City streets, no more than 300 linear feet of trench shall be open at any one time.
- City Code prohibits the placement of debris, sod, earth, sand, gravel, concrete, or any other construction or waste materials in any street, gutter, alley, or public place (Section 114-31).
- Trench dewatering activities require BMPs and must discharge in a manner that will not negatively affect streams, wetlands, drainage systems, or off-site property.
- Vault dewatering activities require special discussion within the SWMP.

3.3.5 Re-assigning or Transferring Permit Coverage

Existing Permittees remain responsible for permit compliance on their site until their permit is completely closed out as described in Chapter 5 of this Rules and Regulations, current edition, or until new permittee(s) obtain permit coverage for all of the previously permitted site. When new permittee(s) obtain coverage for portions of an existing permitted site, the former permittee remains responsible for the portions of the site not covered under the new permit(s), until those portions are completely closed out as described in Chapter 5, or until coverage for those portions of the site is obtained under another **COA Stormwater Quality Discharge Permit for Construction Activities** by another Permittee. The new Permittee shall be required to file

the appropriate fees and to provide the required fiscal security at the time the transfer paperwork is submitted to the City of Aurora.

Upon transfer of the Permit, the new Permittee is required to follow the existing SWMP requirements as outlined and approved in both the narrative and design drawings. The new permittee may elect to develop their own SWMP and submit it for approval through the normal Civil Plans Review Process, including review fees. The new SWMP shall be submitted, reviewed and approved prior to transferring the permit. See Chapter 2 for more requirements.

A new Permittee may apply to take on permit coverage for all or a portion of an existing active permitted site, using the 'Application to Transfer Permit Coverage' or 'Application to Reassign Portions of Permit Coverage' forms provided in Appendix A of this manual. Along with the Application to Transfer or Reassign Permit Coverage, drawings that clearly show the area(s) and BMPs for which the new Permittee is taking responsibility must be submitted. This drawing does not need to be signed and stamped by a Colorado licensed professional engineer unless changes are desired or needed. When a permit is transferred or reassigned, the new Permittee must call for an initial site inspection. Prior to the transfer of permit, the new Permittee may request that the existing Permittee request an initial closeout inspection of the site prior to completing the transfer. This initial closeout inspection should be a joint inspection with the existing and new Permittee's representatives. The new Permittee shall accept all existing site conditions "as is" noted in the initial closeout inspection. The City will request in writing verification of acceptance, including but not limited to liabilities, deficiencies and additional requirements as noted during the previous site's inspections.

3.4 After Construction is Complete

After construction is complete, after the site has received initial closeout acceptance, and until final permit closeout, Permittees shall self-inspect the site at least once every 30 days, and within 24 hours after precipitation and snowmelt events, that creates runoff to cause erosion. If the site has no construction activities occurring following the storm event, post-storm inspections shall be conducted prior to recommencing construction activities, but no later than 72 hours following the storm event. The inspection logs and maintenance records shall continue to be documented and maintained by the Permittee. BMPs shall be repaired and maintained as necessary until site stabilization is approved and the permit is closed out (refer to Chapter 5 for a description of the permit closeout process). The frequency of COA Water Department Erosion Control supervisor/staff's routine unannounced inspections may be evaluated at this time; however depending on site specific conditions, the original inspection frequency may be maintained during this period.

Temporary soil erosion control facilities shall be removed and earth disturbance areas graded and stabilized with permanent soil erosion control measures in accordance with the approved

plans and specifications. No temporary BMP features shall be abandoned in place after work has been completed and the final stabilization or landscaping plan has been executed. The Permittee may not close out their CDPHE-CDPS permit without obtaining a passing final closeout inspection from the City of Aurora.

THIS PAGE IS INTENTIONALLY BLANK

Chapter 4: City of Aurora Stormwater Quality Discharge Permit Inspections and Enforcement

The City of Aurora’s (COA) Water Department’s Erosion Control’s process for **COA Stormwater Quality Discharge Permits for Construction Activities** is similar to the inspection process used by the Colorado Department of Public Health and Environment (CDPHE) – Water Quality Control Division (WQCD).

4.1 Procedures and Processes

4.1.1 What to Expect

Once the initial inspection for the construction site has been successfully completed and the permit executed, further inspections will be conducted by COA Erosion Control supervisor or staff with or without advance notice throughout the duration of construction and until permit closeout.

COA Erosion Control supervisor and staff shall conduct random, unannounced field inspections to verify compliance with the **City of Aurora Stormwater Quality Discharge Permit for Construction Activities**. These inspections revolve around a review of site conditions and any existing or potential impacts to water quality. A typical inspection will entail an attempt to contact the site superintendent or their designee, a review of the Permittee’s paperwork and SWMP updates, visual examinations of site conditions, construction activities, work practices and BMPs. Upon completion of the inspection, a summary of findings will be presented to the Permittee or their designated representative. The time frame for addressing inspection findings begins as soon as the inspection is complete.

The BMPs to be reviewed may be structural, physically installed features (also known as “structural BMPs”) or administrative/procedural activities that are part of the Permittee’s work practices and procedures (also known as “non-structural BMPs”). Installed BMPs will be reviewed for correct application, correct installation, adequacy and maintenance. SWMP design drawings for the project phase of construction and any applicable supplemental drawings from the approved civil set or planning set (landscape drawing) are used to verify features that should be in place, and their specific locations. COA Water Department Erosion Control supervisor and staff shall utilize these supplemental drawings to verify implementation of general features and not verify or inspect for specifics. For example, the landscape plan will be utilized to verify the type of permanent stabilization - sod vs. rock, not to say the rock is the correct size or sod is the correct species.

4.1.2 How to Comply

To protect stormwater quality, maintain permit compliance, the Permittee needs to be prepared for random field inspections, the construction site should be routinely checked by the Permittee/SWMP Administrator for proper BMP installation, and to determine if BMPs continue to function effectively and appropriately in accordance with the SWMP (narrative and drawings). Any loss of integrity, loss of function, or breaches identified shall be repaired immediately to reduce the potential for stormwater to transport sediment and other pollutants into storm drains or off-site. Similarly, in areas where off-site stormwater may flow on to (run on) and through the project site, perimeter control BMPs should be implemented to route off-site stormwater around the site rather than through the site, if possible; site conditions may warrant that run on be controlled and conveyed within the site under construction. BMPs for run on will need to be determined and addressed in the SWMP appropriately.

Good housekeeping practices such as proper waste handling, material storage, waste disposal, street sweeping and effective vehicle tracking control measures also reduce the potential for stormwater contamination.

For additional information, refer to the “Common Compliance Problems During Inspections” (page 36) section of the EPA Stormwater Pollution Prevention Plan (SWPPP) Guide. (http://www.epa.gov/npdes/pubs/sw_swppp_guide.pdf)

4.1.3 Coordination with City of Aurora

If a project involves or is adjacent to Parks, Recreation and Open Space (PROS), Capital Projects Division (CPD) or Public Works (PW) property or facilities, Permittees shall call the appropriate representative of the PROS Department, CPD or PW regarding all inspections. Such projects are required to meet all applicable specifications, details, drawings, and other requirements of the PROS Department, CPD or PW prior to Final Acceptance. Permittees of City owned projects shall be subject to the same requirements of these Rules and Regulations throughout the construction process, including final stabilization, inspection requirements and if necessary the enforcement escalation policy.

4.2 Inspection Process Phases & Enforcement Escalation

COA has classified several types of inspections that may be conducted during the duration of the project. These include but are not limited to an initial inspection required to execute the permit/permitted phase, routine, follow up(s), post precipitation, initial and final closeout inspection(s).

Each site will have a Site Impact Assessment Score associated with its permit. The score is based on various features and site conditions. This Site Impact Assessment Score is prepared by COA

Erosion Control supervisor or staff, not the permittee or his designated representative. This score will be used to determine the routine inspection frequency utilized by the City of Aurora Erosion Control Staff for their routine, unannounced inspections. The inspection frequency is currently set at monthly, bi-monthly and quarterly, but the City reserves the right to either increase or decrease the inspection frequency depending on site conditions observed in the field. See Appendix B for the Enforcement Escalation Policy and Site Impact Assessment Score. Please be aware that the City reserves the right to change these policies based upon recommendations and/or deficiencies observed by the WQCD during audits or oversight reviews of the City's MS4 permit or during internal audits.

The site score can be provided to the Permittee in several different ways. City of Aurora Erosion Control supervisor or staff may provide the information during the Erosion Control Kick Off Meeting, City of Aurora Initial Inspection (verbally or in the SMEC report itself) or the Permittee may contact the appropriate personnel either via phone or email to obtain the information.

4.2.1 COA Stormwater Management and Erosion Control Inspections (SMEC)

SMEC Inspections and subsequent reports are not intended to exhaustively identify every violation or deficiency which may exist on a site. Similarly, photo logs which may accompany the SMEC Inspection Reports are not intended to document every issue, every instance of every issue of concern, or every violation identified or existing on a site; they are a representative sample of the site's condition. COA SMEC Inspection Reports are not intended to fulfill the requirement for self-inspections to be conducted by the Permittee.

In general, COA Stormwater Management and Erosion Control Inspections result in the following:

1. A COA Stormwater Management and Erosion Control (SMEC) Inspection report is provided to the Permittee's SWMP Administrator.
2. The report identifies one of the following two situations:
 - Passing Inspection: Only working items have been identified. No violations are noted on the SMEC inspection report.
 - Notice of Non-Compliance: Violations are noted. An inspection report with one or more violations constitutes a Notice of Non-Compliance. Permittee must correct the identified violations as detailed below.

If violations are noted during a site inspection, resulting in a Notice of Non-Compliance, the Permittee shall make the necessary corrections. In accordance with the City of Aurora Enforcement Escalation Policy, the Permittee shall provide written and photo documentation of the remediation of the noted significant violations to the City of Aurora Erosion Control Department (supervisor and appropriate staff) for review within two (2) business days from the end of the inspection, not from when the Permittee receives the SMEC report. Permittee documentation will be reviewed and a determination will be made if the documentation

addresses the outstanding significant violations. If the documentation does not provide enough information to demonstrate appropriate remediation of the noted significant violations a follow up inspection will be conducted as scheduled by COA Erosion Control Supervisor/Staff within three (3) business days to five (5) business days from the original inspection date to resolve the Notice of Non-Compliance. The Permittees' response does not negate the violations noted on the COA SMEC Inspection report; however, it may allow the Permittee back into the routine inspection cycle. The significant violations noted will be in the file and documented per the enforcement escalation policy.

If COA Erosion Control Staff note the same violation(s) requiring maintenance on four (4) inspections, this BMP feature shall then be noted as a significant violation. Once this significant violation has been noted, it will continue to be noted as a significant violation in subsequent inspections. The Permittee may have this BMP revert back to violation(s) requiring maintenance after three (3) inspections indicating that this feature is working at all times.

The following is a general guidance for violation(s) requiring maintenance vs. a significant violation. This is not a definition.

Violation requiring maintenance:

Items could include observances noted during an inspection where it has been determined that the condition of the BMP is such that there is minimal potential for pollutants to be conveyed to or impact the MS4. It is possible that several observances of the same violation requiring maintenance item could escalate the finding into a significant violation.

Significant Violation:

Significant violations could include observances noted during an inspection where it has been determined that the condition of the BMP is such that there is significant potential for pollutants to be conveyed to or impact the MS4. It is possible that the observed significant violation may escalate to the Enforcement Escalation Policy.

The MS4 consists of several types of conveyances which include but are not limited to curb, gutter, storm sewer, storm sewer appurtenances, swales, drainageways and channels.

4.2.2 Enforcement Escalation

An increased level of response by the City is possible in the event an inspection discovers violations of higher severity or impact. Please refer to the City of Aurora Construction Sites Program Enforcement Escalation Policy for specifics (see Appendix B). The following lists types of Enforcement Actions that may be taken by the City following a City inspection:

1. **Notice of Violation (NOV):** Indicates a site with site-wide or systematic BMP issues and/or repeated non-compliance or the site began work without obtaining an executed City of Aurora Stormwater Quality Permit. Non-compliant items must be resolved immediately, including installation and appropriate inspections. For larger items requiring a remediation plan prepared by the Colorado licensed professional engineer,

timeframes for implementation of remediation shall be required to be submitted to the COA Erosion Control Inspections Supervisor or designee within two (2) business days. Site-wide or systemic violations include (but are not limited to) BMPs not installed appropriately, BMPs that are exhausted or overwhelmed, illicit discharges, and site conditions with imminent potential BMP failure.

To resolve an NOV, the Permittee shall make the necessary corrections and reschedule a COA inspection within the timeframes outlined in the NOV documentation from the COA . Follow up inspections for an NOV will occur within five (5) business days of the issuance of the NOV.

- 2. Immediate Clean Up Order (ICO):** Indicates a site with an immediate failure that may have resulted in a pollutant entering a conveyance or impacting a Waters of the State or a conveyance to a Waters of the State.

To resolve an ICO, the Permittee shall make the necessary corrections and reschedule a COA inspection within the timeframes outlined in the ICO documentation from the COA.

The Immediate Clean Up Order is issued in conjunction with an NOV. Follow up inspections shall be conducted within two (2) business days of the issuance of the ICO.

- 3. Stop Work Order (SWO):** Indicates a site with egregious violations or repeated unresolved NOVs. Egregious violations are defined in the Introduction of this manual. Stop Work Orders require immediate stop of all construction activities, and remediation of all violations, before construction activities can resume. If a Stop Work Order is ignored, further action may be taken by the City with enforcement measures which may include permit revocation and/or placing the Permittee on environmental hold.

To resolve a Stop Work Order, the Permittee shall make the necessary corrections and reschedule a COA inspection. A stop work order will remain in effect until a passing inspection conducted by COA Erosion Control Supervisor/Staff is achieved.

Monthly and bi-monthly sites will receive five (5) non-compliant inspections and quarterly inspection sites will receive four (4) non-compliant inspections prior to the issuance of a Stop Work Order.

The site may experience other methods of Enforcement Escalation; these other methods may include Permit Revocation, Withholding City Services, Environmental Hold and Property Liens. Permittees shall be notified when these Enforcement options are going to be utilized.

The general inspection process is summarized in Exhibit 4-1 below.

THIS PAGE IS INTENTIONALLY BLANK

City of Aurora Inspection/Enforcement Process ¹

November 2010

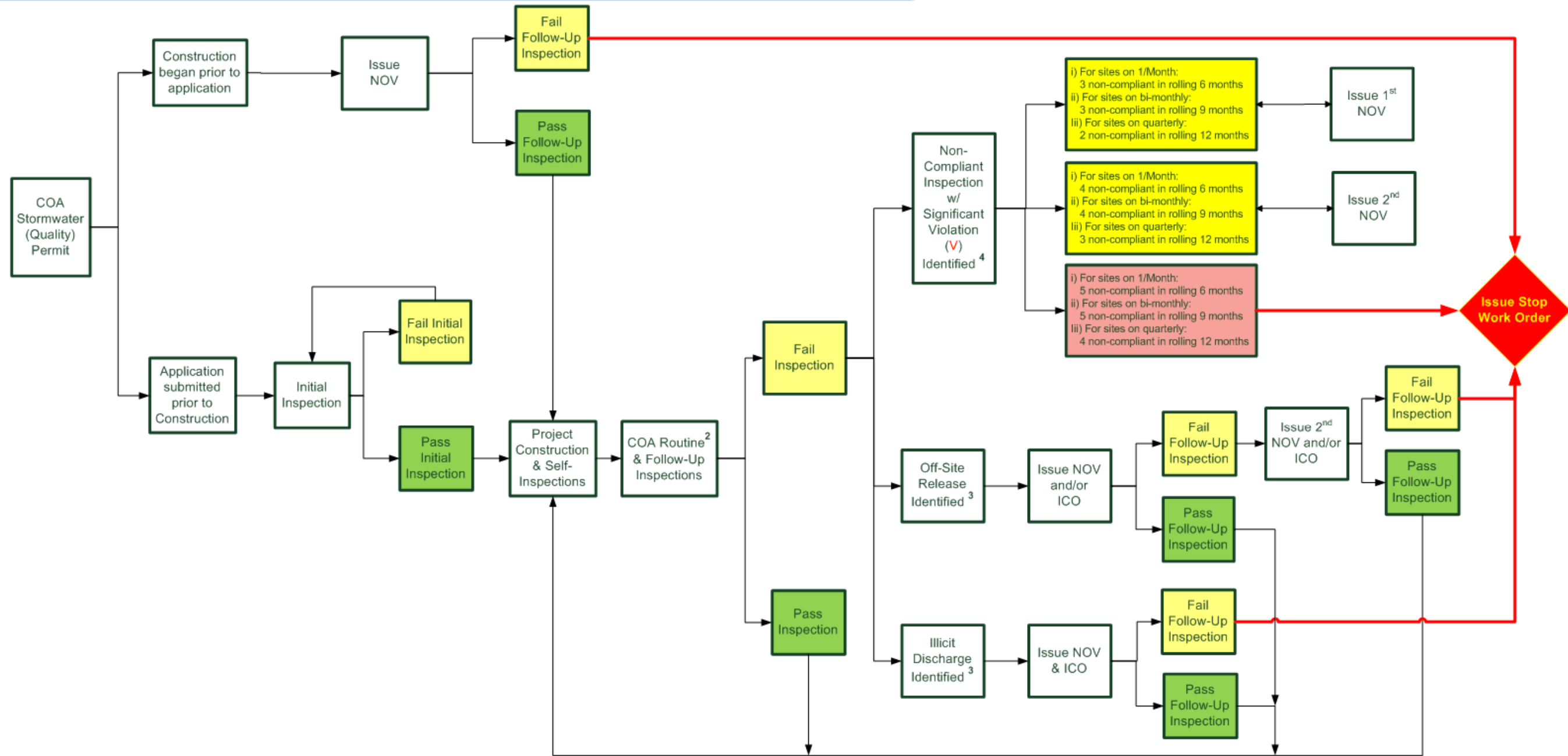

¹ The City may elect to shorten the City's enforcement response depending upon the severity, magnitude, impact and/or location of the identified deficiency(s), illicit discharge or off-site release.

² City of Aurora (COA) Routine inspections are based on the results of an impact analysis and generally are conducted according to the following: High Impact = 1 inspection per month; Medium Impact = 1 inspection bi-monthly; Low Impact = 1 inspection per quarter. Site impact scores will be evaluated on a periodic basis and the frequency of site inspections may be adjusted as appropriate. The inspection frequency may also be adjusted based on available staff resources, number and types of projects ongoing within the City's boundaries and a site's compliance history.

³ If an illicit discharge or off-site release is noted during the course of a follow-up inspection, the site will be issued an NOV/ICO/SWO in accordance with this procedure.

⁴ A site receiving three (3) inspections with the same significant violation (V) identified within a six (6) month period, regardless of whether they are the result of a follow-up or routine inspection, will be issued a notice of violation (NOV). If the site fails the inspection following the issuance of a second NOV for the same significant violation (V) within six (6) months, the site will be issued a stop work order (SWO). Please note that the severity and magnitude of the site issue(s) may cause the process to be escalated faster or more directly.

EXHIBIT 4-1

PAGE INTENTIONALLY LEFT BLANK

4.2.3 What will the COA Erosion Control Department be looking for?

City of Aurora Water Department Erosion Control Staff (Supervisor/Inspector(s)) typically make unannounced site visits, but may make courtesy calls to notify contractors that they will be on-site. During the site visit, COA Erosion Control staff may consider, inspect, and evaluate any or all of the following:

- Outfalls and discharge points for evidence of sediment migration, pollutants, or erosion.
- Site boundaries and perimeter controls for containment with some form of sediment barrier.
- Ponds, basins, traps, drainage ditches/swales, and other water quality features for correct construction, function, protection, integrity and maintenance.
- Disturbed areas for correct phasing and dormant areas not currently being worked that require stabilization, temporary seeding or other means of cover.
- Areas with final stabilization for germination, adequate cover, and need for re-application or maintenance.
- Paved surfaces, for evidence of dirt tracking, dirt ramps, need for cleaning, installation of Vehicle Tracking Pads, and sediment barriers installed adjacent to disturbed sections, including paved sections interior to a site.
- Inlets/outlets for correct and adequate protection, maintenance or staining from pollution sources.
- Material storage and waste handling areas and practices to verify that appropriate measures are in place and exercised to manage all potential pollution sources. This will include waste receptacles, lay-down and staging areas, designated liquid waste washout areas, fuel storage and waste piles.
- Storm events and seasons.
- Appropriate controls for site drainage and management of run-on.
- Other implemented or required procedural, non-structural or administrative BMP control measures.
- Documentation of required self-inspections, Permittee maintenance logs and SWMP updates.
- Consistency between current, site-specific SWMP and installed/implemented controls and site conditions.
- Demolition activities, including saw cutting operations, for adequate waste management.
- Vertical construction BMPs, if necessary, for building construction.
- Appropriate management of processed water, such as water from equipment.
- Work is being conducted within the approved limits of construction.

This list is not intended to be all-inclusive but is intended to familiarize Permittees with the general scope of COA Stormwater Management and Erosion Control Inspections for compliance with Stormwater Quality Discharge Permits for Construction Activities.

4.2.4 What constitutes a COA Stormwater Quality Discharge Permit for Construction Activities violation?

Site conditions that constitute **non-compliance** include, but are not limited to: BMPs that are not installed at all or have been removed without COA approval or implementing a further redundant measure, not installed correctly, not implemented correctly for the intended use, neglected, or in need of significant maintenance or replacement; portable toilets that are improperly stationed on paved surfaces or at curb flow lines; evidence of liquid waste or washouts that are discharged directly onto the ground without containment; a concrete washout area that is near failure; a pond that has no means of discharge; fuel leaks/spills that have not been properly remediated; or inadequate vehicle tracking control measures to reduce and minimize sediment tracking onto paved sections. Repeated neglect and/or findings from previous reports that have not been adequately addressed within the required time frame(s) may also be considered significant violations.

4.2.5 Appeals Process for Reconsideration of Enforcement Action

1. Applicants may appeal City of Aurora Enforcement action(s) imposed against the Permittee.
2. Appeals must be submitted in accordance with the following:
 - i. Appeals must be submitted in writing to Aurora Water to the attention of the Environmental Permitting & Compliance Administrator within three (3) business days of receiving notification of a formal enforcement action. Appeal requests not submitted (e.g., postmarked or submitted electronically) within the three (3) business day limit will not be reviewed and will be considered a denied appeal.
 - ii. Appeal requests will be reviewed by a committee consisting of Aurora Water's Engineering Manager, Environmental Permitting & Compliance Manager and a representative of the City Attorney's office. The City's Parks, Recreation and Open Space and Public Works Departments will be consulted as appropriate. These committee members may designate other representatives to participate if necessary.
 - iii. The committee will make a recommendation to the Director of Aurora Water for a final decision on the appeal.
 - iv. The City of Aurora Water Department will respond to the appeal within four (4) business days of receipt of the appeal.
3. Submitting an appeal does not waive or relieve the obligations and timelines associated with the Enforcement Action(s).

4.2.6 City's Ability to Recover Costs of Correction

The City may access a Permittee's posted fiscal security to recover the costs of site correction or restoration in extreme cases when the Permittee fails to correct or restore a site following an Enforcement Action(s). In these cases, the City may draw on the Permittee's posted fiscal security for the amount required by the City to make the necessary modifications and improvements to the site as may be needed to achieve compliance and to correct the site in a manner consistent with the approved SWMP, up to the face amount of the fiscal security. The City may correct the site to be in compliance with the Permit either by itself, or by contract with a third party, or by assignment of its rights to a successor Permittee who has acquired the subdivision/project by purchase, foreclosure, or otherwise. The City, or a Contractor under contract with the City for such work, or any such successor Permittee, their agents, employees, and contractors shall have the non-exclusive right to enter the subject property for the purpose of correcting the site to be in compliance with the permit. Features installed by the City with the use of Permittee funds become the responsibility of the Permittee for ongoing maintenance and removal.

THIS PAGE IS INTENTIONALLY BLANK

Chapter 5: Permit Closeout

Upon completion of construction activities, a few steps need to be taken for permit closeout, including clean-up and final stabilization. The closeout process for **City of Aurora Stormwater Quality Discharge Permits for Construction Activities** is discussed herein.

5.1 Summary of Permit Closeout Steps

The general process to closeout a COA Stormwater Quality Discharge Permit for Construction Activities is summarized as follows (See Exhibit 1-1 in Chapter 1):

1. Permittee contacts a COA Water Department Erosion Control Staff to set up an initial closeout inspection at least 72 hours in advance of the desired initial closeout inspection time frame. The purpose of the initial closeout inspection is to verify that construction and earth-disturbing activities are complete, and that the site has been seeded, landscaped, covered with pavement or structures, or otherwise stabilized per the approved SWMP/landscape plan. The landscaping plan or permanent stabilization measures per the approved SWMP should be fully executed prior to scheduling the Initial Closeout inspection.
2. Permittee maintains perimeter controls and inlet protections in place, while waiting for vegetation to establish itself.
3. Permittee performs and documents inspections of site at least every 30 days, and after precipitation events (rain, snow, or other) and snow melt events resulting in runoff, and maintains cover, including re-installation if needed.
4. COA Water Department Erosion Control Staff/Supervisor shall periodically check the site for surface erosion, to verify the integrity of mulch and blanket installations and verify that adjacent properties are not impacted by stormwater runoff from site.
5. When vegetative cover has established, the Permittee contacts the City for final closeout inspection. This typically occurs 2-3 years after the initial closeout inspection.
6. Permittee applies for closeout of Permit. The closeout application form is given in Appendix A.
7. Appropriate COA Water Department Erosion Control Staff performs a closeout inspection to verify if sufficient vegetative cover is in place (established uniform density matching at least 70% of pre-disturbance vegetative density coverage, no bare spots, etc. refer to sections 5.2.7 and 5.2.8 for additional requirements). If coverage is sufficient, the next step can be taken; if not, re-seeding may be necessary, or it may be

necessary to wait for additional growth to develop for adequate coverage. Another inspection needs to be scheduled once sufficient coverage is achieved.

8. Permittee removes perimeter controls and inlet protections.
9. Permittee is notified that the COA SWQP and CDPHE's CDPS permit may be evaluated for closure. The Permittee provides the required paperwork to close out the COA SWQP. Upon receipt of the paperwork and based upon the COA Erosion Control Supervisor/Staff findings, the COA may close out the permit in the COA internal electronic tracking system, notifies the Permittee that the permit has been closed out, and releases the Permittee's fiscal security. (The City's internal permit and plans review tracking system is built on the Application Management and Data Automation software, and thus the City's permit and plans review tracking system is often referred to as "AMANDA".) CDPHE's CDPS permit shall not be closed prior to final acceptance by the City of Aurora. If the Permittee closes out the CDPHE permit, the Permittee shall receive a violation and the State shall be notified.
10. Permittee shall provide COA a copy of CDPHE's NOI/NOT to verify closeout.

5.2 Detailed Instructions for Permit Closeout

Details regarding Permit closeout are discussed in this section.

5.2.1 Preparation for the Closeout Inspection

Permittees should do the following to prepare for an Initial Closeout Inspection.

1. Ensure all streets, sidewalks and flow lines (including storm sewers) are clean of sediment. Clean all inlets, trickle channels and all other drainage features, including storm sewers (piping and appurtenances). Dispose of solids properly (i.e. landfill or other approved disposal facility).

Note: WASHING OF STREETS, SIDEWALKS AND FLOWLINES IS PROHIBITED UNLESS PRE-APPROVED BY COA IN WRITING THROUGH A VARIANCE WITH APPROPRIATE AND REDUNDANT BMPs.

2. Remove certain temporary erosion and sediment controls (as indicated in the SWMP or as necessary) that will not be functional while vegetative cover is becoming established.
3. Install/maintain any other erosion and sediment control BMPs that will be functioning during the vegetation establishment period, per the COA-approved and updated, site-specific SWMP.

4. Ensure all disturbed areas are drill seeded and crimp mulched, hard armored, provided with cover or otherwise stabilized, per COA criteria.

Failure to complete the above items may result in Enforcement Action.

5.2.2 Scheduling the Initial Closeout Inspection

After preparing the site and completing the above items, the Permittee schedules an initial closeout acceptance inspection with a COA Erosion Control Staff at least 72 hours ahead of the desired initial closeout inspection time frame. If the project involves or is adjacent to PROS property or facilities, the Permittee shall also call PROS to request a representative to be present at the closeout inspection; this also includes projects that involve CPD and PW. This inspection should be scheduled a minimum of two weeks prior to a scheduled request for a Building Permit (if applicable), Temporary Certificate of Occupancy (TCO), or Certificate of Occupancy (CO) (This applies in situations when overlot grading is done separately in advance of vertical construction.)

5.2.3 Initial Closeout Acceptance

Representatives of the Permittee(s), including the SWMP Administrator, shall attend the Initial closeout inspection along with a COA Water Department Erosion Control Staff.

The following agenda items are addressed during the initial closeout inspection:

1. Inspection of final BMPs. Installation of all final BMPs are inspected, including topsoil spreading, soil preparation, and drill seeding and crimp mulching and/or other installed landscaping features.
2. Inspection of Site Cleanup. Cleanup of the site and adjoining streets is verified, along with the storm sewer and associated appurtenances.
3. Vegetation Requirements. The required vegetation inspections and coverage are described.

5.2.4 Special Closeout Requirements

Special requirements apply to certain types of projects as described below.

1. Detached Single-Family Residential Projects - Initial acceptance sign-offs are required from COA Water Department Erosion Control Staff prior to any release of Engineering holds on Building Permits or water meters for detached single-family residential projects. If the filing is divided into separate grading phases, initial closeout acceptance (part of the WQD Permit Process) is required for each phase until the entire filing is accepted.

2. Commercial, Industrial, and Multi-Family Residential Projects - For commercial, industrial and multi-family sites, the Public Works and the COA Water Department Erosion Control Staff must sign-off prior to release of a CO, TCO, or water meter. Prior to the initial closeout inspections, the Permittee shall prepare the site in accordance with 'Preparation for the Closeout Inspection' above.

5.2.5 Corrections to Site

The Permittee(s) shall make corrections to the site to address deficiencies noted by the COA Water Department Erosion Control Staff. If the required corrections are substantial, a follow-up inspection may need to be scheduled prior to issuing initial closeout acceptance.

5.2.6 Partial Acceptance of Phased Single-Family or Multi-Family Residential Projects

Phasing of the subdivision improvements and lots shall be such that the streets and lots are accessible by a street that has already received Initial Acceptance by COA, or will receive Initial Acceptance as part of the accepted phase. The phased SWMP includes erosion and sediment control measures for each phase in order to protect the phase that will obtain Initial Closeout Acceptance by the City.

All site improvements or subdivision improvement requirements shall be complete for each phase for which Initial Closeout Acceptance is applied for, including all drainage improvements necessary to serve that phase. Detention and water quality facilities that serve one or more phases shall be installed when the first phase that drains to the facility is constructed. Once all the streets, curbs and gutters, and storm sewer drainage improvements have been completed in a phase and all the grading, erosion and sediment controls have been installed or repaired per the Post Paving SWMP, inspections shall be made by the COA Water Department Erosion Control Staff. If the COA Water Department's Erosion Control Staff finds all items to be compliant with COA requirements, a release of Engineering hold shall be granted and a request to the Building Division may be made to obtain building permits. If there are deficient items, the Permittee shall make the necessary corrections and reschedule an inspection.

5.2.7 Establishment of Vegetation

Once a site has had Initial Closeout acceptance, while waiting for vegetation to establish, Permittee(s) shall conduct the following inspections and maintenance operations:

1. Inspect seeded and mulched areas monthly and after precipitation events (rain, snow, or other) and snow melt events resulting in runoff until 70% of pre-disturbance vegetative cover is achieved to achieve permit closeout. If repairs are needed, reseed

and re-mulch/blanket the site as needed or as recommended by the COA Water Department Erosion Control Staff for areas failing to meet the required coverage.

2. Fill any eroded rills and gullies with topsoil prior to any reseeding.
3. Control noxious weeds in a manner acceptable to the COA Water Department Erosion Control Staff so that they do not exceed the limits below under the Required Vegetation Cover and Control of Noxious Weeds.

In addition, COA environmental inspections staff will make periodic inspections of the revegetation area, the frequency may be evaluated and adjusted by the COA Water Department Erosion Control Supervisor, in conjunction with Staff.

5.2.8 Required Vegetation Coverage

Required coverage for permanent, temporary and low-growth native grass seed mixes is defined as follows:

1. Coverage shall entail a minimum uniform density of 70% of the pre-disturbance vegetative density with a minimum height of 3 inches. The vegetation shall be uniform and of the variety and species found in the COA approved mixes or in the approved SWMP.
2. The number and size of non-vegetated areas within the area of disturbance shall be reviewed and evaluated by City of Aurora Erosion Control Staff/Supervisor during the final closeout inspection. This evaluation shall take into account the following at a minimum:
 - area of disturbance (40 acre site vs. 1 acre site)
 - location of non-vegetated areas (i.e. next to an inlet would be an area of concern)
 - type of vegetation established (weeds vs. target species)
 - evidence of visible erosion within the site
3. If a nurse crop has been utilized on this site, at least 50% of the 70% must be of the targeted species within a 2 foot by 2 foot area. This review and evaluation shall take into account the area of disturbance (40 acre site vs. a 1 acre site) in regards to how many times the density is verified.
4. Free of eroded areas.
5. Free of noxious weeds appearing on the Colorado Department of Agriculture's List A. The total area covered with weeds from List B shall be less than 0.5% of the entire revegetation area. The total area covered with weeds from List C shall be less than 1%

of the entire revegetation area. In addition, if weeds from List B or C are present, documentation of treatments or measures to control these weeds must be provided.

Required coverage for turf grass areas shall be defined as follows:

1. At least 80% vegetative cover of grass species planted.
2. No bare areas larger than 4 square feet, 2 feet by 2 feet or equivalent.
3. Free of eroded areas.
4. Free of noxious weeds appearing on the Colorado Department of Agriculture's List A. The total area covered with weeds from List B shall be less than 0.5% of the entire revegetation area. The total area covered with weeds from List C shall be less than 1% of the entire revegetation area. In addition, if weeds from List B or C are present, documentation of treatments or measures to control these weeds must be provided.

Within Parks, Recreation and Open Space properties follow the requirements contained in the Parks, Recreation and Open Space standard specifications, which can be downloaded at the following location:

http://www.auroragov.org/AuroraGov/Departments/Parks_Open_Space/Publications/025389.

5.2.9 Control of Noxious Weeds

COA requires Permittees to control noxious weeds on their property in accordance with the Colorado Noxious Weeds Act and with any Weed Management Plans established by local municipalities. COA has adopted the State of Colorado, Department of Agriculture Noxious Weed Management Program. Noxious weeds negatively impact agriculture, water quality, recreational opportunities, and wildlife. For these reasons, all projects subject to acceptance for final revegetation shall meet the above requirements regarding noxious weeds.

Information is given in Appendix H to be used as a guide to identify noxious weeds on project sites and to take early measures to control the weeds in the early stages of establishment. It is acceptable to have some noxious weeds from List A on the site, but no noxious weeds from List C shall be present at the site. Advice regarding the control of noxious weeds may be obtained by contacting the COA PROS Department.

5.2.10 Acceptance of Vegetation

Once vegetation has reached the required coverage (70% of pre-disturbance vegetative density, no bare spots, etc), Permittees contact a COA Water Department Erosion Control Supervisor or Staff for a Vegetation Density Review Inspection.

COA Water Department Erosion Control Supervisor/Staff will review the site vegetation in accordance with the information provided in the approved SWMP meets the required coverage and whether noxious weeds have been adequately controlled. If the required coverage has been met, the COA Water Department Erosion Control Supervisor/Staff will issue written acceptance of the vegetation and give the Permittee instructions to remove remaining on-site BMPs. If the required coverage is not met, repairs or corrections will have to be made by the Permittee and a follow-up Vegetation Acceptance Inspection will need to be scheduled once the vegetation meets the required coverage.

If it is noted that maintenance (mowing, weed spraying) has been done to a site and this work has impacted the targeted species, the permit may be required to be kept open for an extended period of time to ensure that the targeted species growth is achieved.

5.2.11 Removal of On-site BMPs

After obtaining written acceptance of the vegetation coverage, the remaining on-site BMPs shall be removed and properly disposed of. The site shall be cleaned up and any areas disturbed as a result of the BMP removal shall be adequately stabilized. The Permittee shall then schedule a Final Closeout Inspection with the COA Water Department Erosion Control Supervisor/Staff.

5.2.12 Final Closeout Inspection

The COA Water Department Erosion Control Supervisor/Staff will check the removal of BMPs and either accept the work or stipulate the corrections that have to be made. If corrections are substantial, the COA Water Department Erosion Control Supervisor/Staff may require that a follow-up final closeout inspection be scheduled with the City.

5.2.13 Release of Fiscal Security

Once Final Closeout Acceptance has been obtained, the Permittee may submit a Release of Fiscal Security Request Form to the COA Permits Technician. After the COA Permits Technician has received a completed request form, it will be signed by the COA Water Department Erosion Control Supervisor/Staff, permit coverage will cease, and the Permittee's Fiscal Security will be released.

THIS PAGE IS INTENTIONALLY BLANK

Index

- adverse impacts, 45
- appeal, 88
- Appeal, 57, 58, 79
- Applicant, 5
- application form, 8, 18, 20, 82
- Aurora Municipal Code, 24, 45
- batch plants*, 2, 9, 11, 13, 39, 43, 46, 47
- Best Management Practice, 5
- BMP. *See* Best Management Practice
- calculations, 42, 53, 54
- CDPHE-WQCD, 2, 22, 25, 56, 64, 65, 66
- cement, 27, 46
- changing conditions, 46
- Cherry Creek Reservoir Control Regulation, 11, 12, 22
- City Code, 1
- City-owned Projects, 5
- City-Owned Projects, 13
- Civil Plans Review, 17, 18
- Commercial, 5, 12, 85
- Commercial Development, 12
- Compliance Assistance, 61
- concrete, 9, 25, 27, 39, 46, 47, 48, 49, 51, 55, 68, 79
- concrete washout, 27, 51, 79
- Construction, 6
- Containment, 6
- Contamination, 6
- corrections, 64, 76, 85, 88
- cost opinion, 42
- Demolition, 78
- Development, 6
- dewatering, 16, 28, 53, 68
- Disturb, 6
- Disturbance area, 6
- Diversion Channels, 54
- Documentation, 65, 78
- Drainageway, 10
- Egregious Violations, 6
- Enforcement, 72, 79
- Environmental Inspector, 17, 64, 78, 84, 85, 86, 87, 88
- exempt, 4, 14
- Experimental BMPs, 49
- Final Closeout Inspection, 88
- final stabilization, 41, 68, 70, 78, 82
- Final stabilization*, 41
- fiscal security, 18, 42, 80, 83
- Fiscal Security, 88
- Fugitive dust, 25
- good housekeeping, 66
- Good housekeeping, 73
- Grandfathering, 4
- grubbing, 6, 30, 31, 60
- Hydraulic mulching, 26
- Hydraulic seeding, 26
- Illicit Discharge, 6
- Initial Closeout, 88
- Initial Site Inspection, 60
- Initial SWMP Drawing, 47
- inlet protection, 30, 55
- interim temporary erosion control measure, 50
- Legally Responsible, 7
- limits of construction*, 13, 47, 49, 53
- Lot Controls*, 52
- Maintenance, 9, 41, 66
- maintenance records, 25
- Master Developer, 8, 15
- Mining, 13
- minent Failure, 6
- mortar, 46
- mylar*, 17
- Non-Structural, 30
- non-structural BMPs, 72
- Notice of Non-Compliance, 8, 74, 75
- Notice of Violation, 6, 8, 75, 84
- noxious weeds, 86, 87, 88
- Operator, 8
- Owner, 8
- Partial Acceptance, 85
- perimeter controls, 30, 31, 50, 78, 82, 88
- Perimeter Controls, 8, 52
- permanent BMPs, 58
- Permit Closeout, 82
- Permittee, 8
- phase, 1, 17, 20, 22, 42, 58, 60, 61, 62, 72, 84, 85, 88
- phased, 27, 44, 62, 88
- Pollutants, 8, 9
- porous landscape detention, 26
- Post Paving, 47, 85
- pre-construction meeting, 19
- receiving water, 28
- Redevelopment, 9
- Removal, 88
- rough cut street controls, 25
- run-on, 50, 56, 78
- Sanitary facilities, 52
- Secondary containment, 46, 51
- sediment basins, 30, 42, 47, 54, 55
- Sediment Control Logs, 53
- self-inspections, 66, 68, 74, 78
- sequence, 26, 46
- signature block, 23, 24, 44, 45
- Slope Drains, 54
- Slope Protection, 50
- SMEC. *See* Stormwater Management and Erosion Control
- Spill Prevention, 33
- Staged*, 44
- stockpiles, 26, 27, 46, 47, 52
- Stop Work Order, 9, 76, 80
- Stormwater (Quality) Discharge Permit for Construction Activities, 1
- StormWater Management Plan, 9
- Straw bales, 46, 49
- Structural, 30
- structural BMPs, 72
- substantial completion, 46, 50
- Surface Stabilization, 49
- SWMP. *See* Stormwater Management Plan
- SWMP Design Drawings, 29
- SWMP Design Drawings, 43
- SWMP Manager, 9, 25, 60, 74, 84
- SWMP Report, 19, 23, 24
- temporary batch plant, 16
- temporary stabilization, 50, 54
- Temporary Stream Crossings, 53
- temporary stream diversion, 49
- Topsoil Stripping, 49
- Transfer or Reassign, 69
- Tree and Natural Feature Protection, 51
- utility*, 2, 6, 8, 12, 13, 14, 15, 16, 30, 31, 44, 68
- utility line construction, 68
- variance, 4, 57
- Vegetation Acceptance, 88
- vegetative cover, 27, 41, 82, 83, 85, 87
- Vehicle Tracking Control, 25, 52
- violation, 61, 74, 79
- Waste Control, 51
- Watercourse, 10
- Waters of the State, 10, 50
- Waterway, 10
- wetlands, 17, 45, 46, 51, 68

THIS PAGE IS INTENTIONALLY BLANK

Appendix A – Permit Application Forms

The attached application forms are to be used by an applicant to obtain a new permit or make changes to an existing permit.

- Application Form for City of Aurora Stormwater (Quality) Discharge Permit for Construction Activities
- SAMPLE City of Aurora Stormwater (Quality) Discharge Permit for Construction Activities
- Application Form for City of Aurora Stormwater (Quality) Discharge Permit from a Temporary Batch Plant
- Application Form to Reassign Portions of the Stormwater (Quality) Discharge Permit for Construction Activities
- Application Form to Transfer Stormwater (Quality) Discharge Permit for Construction Activities
- Application Form for Closeout of City of Aurora Stormwater (Quality) Discharge Permit for Construction Activities

THIS PAGE IS INTENTIONALLY BLANK



CITY OF AURORA
APPLICATION FOR PERMIT



STORMWATER QUALITY DISCHARGE PERMIT FOR CONSTRUCTION ACTIVITIES

COMPLETE ALL SECTIONS OF THE APPLICATION, PRINT OR TYPE ALL INFORMATION
APPLICANT IS: [] OWNER/DEVELOPER [] CONTRACTOR [] RENEWAL

1. Name and Contact Information for Applicant:

Company Name:
Street Address:
City, State and Zip Code:
Legally Responsible Person:
E-Mail Address: Phone: () - x
SWMP Administrator: Title/Position:
SWMP Administrator Phone: () - x
SWMP Administrator E-Mail:

2. Name and Contact Information for Owner/Developer or Contractor, not Listed in #1 above:

Company Name:
Street Address:
City, State and Zip Code:
Legally Responsible Person:
E-Mail Address: Phone: () - x

3. Construction Activity Information:

Street Address or Nearest Cross Streets:
Name of Project, Development or Activity:
Total Area of Project Site: Acres - Area of Project to Undergo Land Disturbance: Acres
Is This Activity Part of a Larger Common Plan of Development: [] Yes [] No

4. Nature of Construction Activity:

[] Single Family Residential [] Multi-Family Residential [] Utility
[] Commercial Development [] City Project [] Roadway

5. COA Approved drawing number:

6. Anticipated Start Date (Month/Date/Year): / / End Date: / /

This Application is Subject to Review and Verification of All Submitted Information and Subsequent Approval by The City of Aurora.

COMPLETE BOTH PAGES AND SUBMIT TO COA PERMIT CENTER WITH:

- ORIGINAL SIGNATURES IN INK
- APPROVED PROBABLE COST SHEET(S)
- FISCAL SECURITY
- \$275 CHECK FOR 12-MONTHS COVERAGE

City of Aurora Municipal Center
15151 E. Alameda Pkwy.
Permit Center, 2nd Flr.
Aurora, CO 80012

All COA Stormwater Quality Discharge (SWQD) Permit Holders are Required to Retain a Hard Copy of the *COA Rules and Regulations Regarding Stormwater Discharges Associated with Construction Activities* Manual (SWMP Manual) on the Jobsite at all Times for Reference and Direction on the Rules, Regulations, Specifications and the SWQD Permitting Conditions for all Construction Activities.

- I HAVE A COPY OF THE COA SWMP MANUAL
- I WILL PURCHASE A COPY OF THE COA SWMP MANUAL WHEN I PICK UP MY PERMIT

Signature of Legally Responsible **Owner**

_____/_____/_____
Date Signed

Printed Name

Title

Signature of Legally Responsible **Contractor**

_____/_____/_____
Date Signed

Printed Name

Title

Signature of City of Aurora Water Dept Plans Review **Engineer**
Approved Fiscal Security Amount: \$ _____

Date Signed



**CITY OF AURORA
STORMWATER QUALITY DISCHARGE PERMIT FOR CONSTRUCTION ACTIVITIES**

PERMIT # _____ **PROJECT** _____

OWNER/DEVELOPER INFORMATION:

(name of legally responsible person)

(company name)

(address)

(city, state, zip code)

(phone)

CONTRACTOR INFORMATION:

(name of legally responsible person)

(company name)

(address)

(city, state, zip code)

(phone)

SWMP Administrator: _____

SWMP Administrator Employed by: OWNER/DEVELOPER CONTRACTOR

SWMP Administrator Information: _____
(phone) (email)

Disturbed Area: _____ (acres) **Approved Plan #** _____ **Anticipated Completion Date:** _____

PERMIT AUTHORIZATION (Permit is not valid without all Signatures):

Permit Counter: _____ **Date:** _____

Permittee: _____ **Date:** _____
 OWNER/DEVELOPER CONTRACTOR

COA
Erosion Control Staff
Member: _____ **Date:** _____

TERMS AND CONDITIONS

- 1) This Stormwater Quality Discharge Permit for Construction Activities, as issued by the City of Aurora-Aurora Water, authorizes the Permittee to discharge stormwater from construction activities within the City of Aurora, as governed by the rules, regulations and specifications detailed in the *Rules and Regulations Regarding Stormwater Discharges Associated with Construction Activities* manual. All demolition, construction and earthwork activities must comply with City code and the criteria established in the COA Rules and Regulations Regarding Stormwater Discharges with Construction Activities, which establish the Permitting Conditions accompanying this Permit and govern all construction activities in the City of Aurora.
- 2) The project listed on this Permit may be inspected at any time by City Erosion Control Staff to verify compliance. Any violations, deficiencies or action items note on a Stormwater Management Erosion Control (SMEC) report must be corrected immediately and documentation is required to be submitted within two (2) business days to the Erosion Control Supervisor and appropriate Staff per the SMEC report language. Permittees may be subject to Stop Work Orders and/or other enforcement action for instances of non-compliances and violations of the conditions of this Permit.
- 3) This Permit must be executed by a City of Aurora Erosion Control Staff or other authorized agent of Aurora Water, to be valid. No construction, demolition or earthwork activities (including clearing and grubbing) are authorized prior to the execution of this Permit. An Initial Inspection must be scheduled with COA Erosion Control Staff, conducted, and passed, prior to Permit execution. Inspections may be scheduled by calling: 720-859-4415.
- 4) This Permit is valid for one year after execution and must be renewed fourteen (14) days prior to expiration to remain valid. This Permit may not be closed until the Final Stabilization criteria detailed in the *Rules and Regulations Regarding Stormwater Discharges Associated with Construction Activities* manual are met.
- 5) The site-specific Stormwater Management Plan (SWMP) for the permitted activity must be implemented according to its terms until the Permit is closed. Control features and practices must be installed and implemented to properly manage all on-site sources of pollution, so that their discharge into drainageways, curb flow lines, storm sewers and storm sewer appurtenances, off the project boundary, or into any water conveyance feature is reduced and minimized, to reduce and minimize the contribution of pollutants to state waters.
- 6) Control features and practices must be appropriately selected so they are adequate for the application. Control features and practices must be effectively installed and proactively maintained in good operating condition such that they will be continually functional.
- 7) It is the responsibility of the SWMP Administrator to continuously evaluate all on-site sources of pollution and their related control features and practices to ensure their appropriate management and verify the function and adequacy of the features and practices.
- 8) Additional features, and/or control measures may be required to ensure and maintain compliance with the permitting conditions. The need and requirement for additional measures may also be noted by COA Erosion Control Staff.
- 9) Any stormwater or other waters discharged into drainageways, curb flow lines, storm sewer, storm sewer appurtenances, off the project boundary, or into any water conveyance feature, and which may reach state waters, shall be subject to the controls identified in this permit.



CITY OF AURORA
APPLICATION TO PERMIT A TEMPORARY BATCH PLANT
DURING CONSTRUCTION ACTIVITIES



COMPLETE ALL SECTIONS OF THE APPLICATION, PRINT OR TYPE ALL INFORMATION

1. Name and Contact Information for Contractor Operating the Batch Plant:

Company Name: _____
 Street Address: _____
 City, State and Zip Code: _____
 Legally Responsible Person: _____
 E-Mail Address: _____ Phone: () - x

2. Name and Contact Information for COA SWQ Permittee for the Project, not Listed in #1 above:

Company Name: _____
 Street Address: _____
 City, State and Zip Code: _____
 Legally Responsible Person: _____
 E-Mail Address: _____ Phone: () - x
 SWMP Manager: _____ Title/Position: _____
 SWMP Mgr Phone: () - x
 SWMP Mgr. E-Mail: _____

3. Construction Activity Information:

COA SWQ Permit # Where Batch Plant will be Operating: _____
 Name of Project, Development or Activity: _____
 Duration of Batch Plant Activity (Month/Date/Year): ___/___/___ to: ___/___/___

4. Nature of Construction Activity:

- | | | |
|--|---|----------------------------------|
| <input type="checkbox"/> Single Family Residential | <input type="checkbox"/> Multi-Family Residential | <input type="checkbox"/> Utility |
| <input type="checkbox"/> Commercial Development | <input type="checkbox"/> City Project | <input type="checkbox"/> Roadway |

5. COA Approved drawing number for the Temporary Batch Plant: _____

COMPLETE BOTH PAGES AND SUBMIT TO COA PERMIT CENTER WITH:

- ORIGINAL SIGNATURES IN INK
- FISCAL SECURITY
- \$275 CHECK FOR 12-MONTHS COVERAGE

City of Aurora Municipal Center
15151 E. Alameda Pkwy.
Permit Center, 2nd Flr.
Aurora, CO 80012

All COA Water Quality Discharge (WQD) Permit Holders are Required to Retain a Hard Copy of the *COA Rules and Regulations Regarding Stormwater Discharges Associated with Construction Activities* Manual (SWMP Manual) on the Jobsite at all Times for Reference and Direction on the Rules, Regulations, Specifications and the WQD Permitting Conditions for all Construction Activities.

- I HAVE A COPY OF THE COA SWMP MANUAL
- I WILL PURCHASE A COPY OF THE COA SWMP MANUAL WHEN I PICK UP MY PERMIT

Signature of Legally Responsible **Plant Operator**

_____/_____/_____
Date Signed

Printed Name

Title

Signature of Legally Responsible **SWQ Permit Holder**

_____/_____/_____
Date Signed

Printed Name

Title

This Application is Subject to Review and Verification of All Submitted Information and Subsequent Approval by The City of Aurora.



CITY OF AURORA
APPLICATION TO RE-ASSIGN PORTIONS OF PERMIT COVERAGE
STORMWATER QUALITY DISCHARGE PERMIT FOR CONSTRUCTION ACTIVITIES



This Application Is To Be Completed by Both the Current Permittee That Is Releasing Coverage Under a SWQD Permit and the New Permittee That Will Be Accepting Permit Coverage. This Application Is Only For the Re-Assignment of Portions of Permit Coverage. If Entire Coverage is Being Released to a New Owner/Operator/Permittee, Use the *APPLICATION TO TRANSFER PERMIT COVERAGE*. All Sections of This Application Must Be Completed, Print or Type All Information.

THIS RE-ASSIGNMENT IS TO BE EFFECTIVE ON: _____

1. To be completed by the new Permittee accepting the Permit re-assignment:

Name and Contact Information for Applicant: APPLICANT IS: OWNER/DEVELOPER

CONTRACTOR

Company Name: _____

Street Address: _____

City, State and Zip Code: _____, _____, _____

Legally Responsible Person: _____

E-Mail Address: _____ Phone: () - x _____

SWMP Administrator: _____ Title/Position: _____

SWMP Administrator Phone: () - x _____

SWMP Administrator Email: _____

2. Name and Contact Information for Owner/Developer or Contractor, not Listed in #1 above:

Company Name: _____

Street Address: _____

City, State and Zip Code: _____, _____, _____

Legally Responsible Person: _____

E-Mail Address: _____ Phone: () - x _____

3. Construction Activity Information:

Street Address or Nearest Cross Streets: _____

Name of Project, Development or Activity: _____

Total Area of Project Site: ____ Acres - Area of Project to Undergo Land Disturbance: ____ Acres

Is This Activity Part of a Larger Common Plan of Development: Yes No

4. Nature of Construction Activity:

Single Family Residential

Multi-Family Residential Utility

Commercial Development

City Project

Roadway

5. (a)Original COA Approved Drawings: _____

(b)Revised COA Approved Drawing: _____

**This Application is Subject to Review
and Verification of All Submitted
Information and Subsequent
Approval by The City of Aurora.**

6. To be completed by the existing Permittee re-assigning Permit coverage:

Name and Contact Information for Permittee: PERMITTEE is: OWNER/DEVELOPER

CONTRACTOR

Company Name: _____

Street Address: _____

City, State and Zip Code: _____, _____, _____

Legally Responsible Person: _____

E-Mail Address: _____ Phone: (____) _____ - _____ x _____

Signature of Legally Responsible Current Permittee Date Signed _____ / _____ / _____

Printed Name Title

COMPLETE BOTH PAGES AND SUBMIT TO COA PERMIT CENTER WITH:

- ORIGINAL SIGNATURES IN INK
- APPROVED PROBABLE COST SHEET(S)
- PROOF OF ESTABLISHED FISCAL SECURITY FOR NEW PERMITTEE
- \$275 CHECK FOR 12-MONTHS COVERAGE (**Not Required until Jan. 1st 2010**)

Aurora Municipal Center - 15151 E. Alameda Pkwy. - Permit Center, 2nd Flr. - Aurora, CO 80012

All COA Stormwater Quality Discharge (SWQD) Permit Holders are Required to Retain a Hard Copy of the COA *Rules and Regulations Regarding Stormwater Discharges Associated with Construction Activities* Manual (SWMP Manual) on the Jobsite at all Times for Reference and Direction on the Rules, Regulations, Specifications and the SWQD Permitting Conditions for all Construction Activities.

I HAVE A COPY OF THE COA SWMP MANUAL

I WILL BE PURCHASING A COPY OF THE SWMP MANUAL WHEN I PICK UP MY PERMIT

I hereby accept re-assignment of the portion of the below listed SWQD Permit that is detailed on the COA approved drawings noted in 5.(b). Original COA Stormwater Quality Discharge Permit for Construction Activities: SWQD Permit # _____

Signature of Legally Responsible **Owner** Date Signed _____ / _____ / _____

Printed Name Title

Signature of Legally Responsible **Contractor** Date Signed _____ / _____ / _____

Printed Name Title

Signature of City of Aurora Water Dept Plans Review **Engineer** Date Signed _____ / _____ / _____

Approved Fiscal Security Amount: \$ _____



CITY OF AURORA
APPLICATION TO TRANSFER PERMIT COVERAGE



STORMWATER QUALITY DISCHARGE PERMIT FOR CONSTRUCTION ACTIVITIES

This Application Is To Be Completed by Both the Current Permittee That Is Releasing Coverage Under a SWQ Permit and the New Permittee That Will Be Accepting Permit Coverage. This Application Is Only For the Transfer of Entire Permit Coverage. If Portions of Coverage Are Being Released To a New Owner/Operator/Permittee, Use the *APPLICATION TO REASSIGN PORTIONS OF PERMIT COVERAGE*. All Sections of This Application Must Be Completed, Print or Type All Information.

THIS TRANSFER IS TO BE EFFECTIVE ON: _____

1. To be completed by the new Permittee accepting the Permit Transfer:

Name and Contact Information for Applicant: APPLICANT IS: OWNER/DEVELOPER

CONTRACTOR

Company Name: _____

Street Address: _____

City, State and Zip Code: _____, _____, _____

Legally Responsible Person: _____

E-Mail Address: _____ Phone: (____) _____ - _____ x _____

SWMP Administrator: _____ Title/Position: _____

SWMP Administrator Phone: (____) _____ - _____ x _____

SWMP Administrator. Email: _____

2. Name and Contact Information for Owner/Developer or Contractor, not Listed in #1 above:

Company Name: _____

Street Address: _____

City, State and Zip Code: _____, _____, _____

Legally Responsible Person: _____

E-Mail Address: _____ Phone: (____) _____ - _____ x _____

3. Construction Activity Information:

Street Address or Nearest Cross Streets: _____

Name of Project, Development or Activity: _____

Total Area of Project Site: ____ Acres - Area of Project to Undergo Land Disturbance: ____ Acres

Is This Activity Part of a Larger Common Plan of Development: Yes No

4. Nature of Construction Activity:

Single Family Residential

Multi-Family Residential Utility

Commercial Development

City Project

Roadway

5. (a)Original COA Approved Drawings: _____

(b)Revised COA Approved Drawing: _____

**This Application is Subject to Review
and Verification of All Submitted
Information and Subsequent Approval
by The City of Aurora.**

6. To be completed by the existing Permittee transferring Permit coverage:

Name and Contact Information for Permittee: PERMITTEE is: OWNER/DEVELOPER CONTRACTOR

Company Name: _____

Street Address: _____

City, State and Zip Code: _____

Legally Responsible Person: _____

E-Mail Address: _____ Phone: (____) _____ - _____ x _____

Signature of Legally Responsible Current Permittee _____
Date Signed

Printed Name _____
Title

COMPLETE BOTH PAGES AND SUBMIT TO COA PERMIT CENTER WITH:

- ORIGINAL SIGNATURES IN INK
- PROOF OF ESTABLISHED FISCAL SECURITY FOR NEW PERMITTEE
- APPROVED SWMP PLAN SHOWING AREA(S) OF RESPONSIBILITY
- APPROVED PROBABLE COST SHEET(S)
- \$275 CHECK FOR 12-MONTHS COVERAGE

Aurora Municipal Center - 15151 E. Alameda Pkwy. - Permit Center, 2nd Flr. - Aurora, CO 80012

All COA Stormwater Quality Discharge (SWQ) Permit Holders are Required to Retain a Hard Copy of the COA *Rules and Regulations Regarding Stormwater Discharges Associated with Construction Activities* Manual (SWMP Manual) on the Jobsite at all Times for Reference and Direction on the Rules, Regulations, Specifications and the SWQ Permitting Conditions for all Construction Activities.

I HAVE A COPY OF THE COA SWMP MANUAL

I WILL BE PURCHASING A COPY OF THE SWMP MANUAL WHEN I PICK UP MY PERMIT

I hereby accept re-assignment of the portion of the below listed SWQ Permit that is detailed on the COA approved drawings noted in 5.(b) and all responsibilities, liabilities, deficiencies, and additional requirements that are associated with the site I am accepting. Original COA Stormwater Quality Discharge Permit for Construction Activities: SWQ Permit # _____

Signature of Legally Responsible **Owner** _____
Date Signed

Printed Name _____
Title

Signature of Legally Responsible **Contractor** _____
Date Signed

Printed Name _____
Title

Signature of City of Aurora Water Dept Plans Review **Engineer** _____
Date Signed

Approved Fiscal Security Amount: \$ _____



CITY OF AURORA
APPLICATION TO CLOSE-OUT

**STORMWATER (QUALITY) DISCHARGE PERMIT FOR CONSTRUCTION
ACTIVITIES**

COMPLETE ALL SECTIONS OF THE APPLICATION, PRINT OR TYPE ALL INFORMATION

PERMITTEE IS: OWNER CONTRACTOR COA Permit # _____

1. Name and Contact Information for Permittee:

Company Name: _____

Street Address: _____

City, State and Zip Code: _____, _____, _____

Legally Responsible Person: _____

E-Mail Address: _____@_____ Phone: (____) ____-____, x_____

SWMP Manager: _____ Title/Position: _____

SWMP Mgr. Phone: (____) ____-____ SWMP Mgr. Email: _____@_____

2. Construction Activity Information:

Name of Project, Development or Activity: _____

Project Address: _____

Is This Activity Part of a Larger Common Plan of Development: Yes No

Is This Activity Being Performed on a Parks & Open Space Department Owned or Managed Property:

Yes No

COA Approved drawing number: 20_____

3. Anticipated Date of Implementation of Final Landscaping/Site Revegetation : / /20

I ATTEST THAT ALL CONSTRUCTION ACTIVITIES HAVE BEEN COMPLETED, 100% OF THE PROJECT HAS AS DESCRIBED IN THE APPLICATION BEEN COVERED WITH STRUCTURES, PAVED SECTIONS, HARD ARMOR AND/OR LANDSCAPING AND THAT TEMPORARY BMPs INSTALLED DURING CONSTRUCTION HAVE BEEN REMOVED*. I AM REQUESTING AN INITIAL CLOSE-OUT INSPECTION FROM THE CITY AND UNDERSTAND THAT MY PERMIT WILL NOT BE FULLY CLOSED UNTIL VEGETATIVE COVER HAS BEEN ESTABLISHED AND ACCEPTED BY A COA INSPECTOR.

Signature of Legally Responsible Agent for Permittee

Date Signed

Printed Name

Title

*IT MAY BE APPROPRIATE TO LEAVE SOME TEMPORARY BMPs INSTALLED UNTIL VEGETATIVE COVER HAS BEEN ESTABLISHED, AT WHICH TIME ALL TEMPORARY FEATURES WILL NEED TO BE REMOVED.

This Application is Subject to Review and Verification of All Submitted Information and Subsequent Approval by The City of Aurora.

THIS PAGE IS INTENTIONALLY BLANK

Appendix B – Escalation Policy

This Appendix contains the current approved City of Aurora escalation policy for Stormwater Management.

THIS PAGE IS INTENTIONALLY BLANK

City of Aurora

Construction Sites Program

Enforcement Escalation Policy

Version 08/16/2010

In accordance with the City of Aurora's Municipal Separate Storm Sewer System (MS4) permit, the City is implementing an enforcement escalation policy that includes specific processes and sanctions to minimize the occurrence of, and obtain compliance from, chronic and recalcitrant violators of erosion and sediment control measures. The following information provides a detailed explanation of the City's procedure to address instances of non-compliance. It is not intended to encompass every possible scenario. In addition, the severity and magnitude of the site issue(s) may necessitate an acceleration of the process. Finally, the City reserves the right to exercise any applicable enforcement provision if it is determined to be necessary in order to return the site to compliance in a timely manner.

The City's Stormwater Construction Sites Program routinely inspects construction sites based on a calculated impact level. This impact level is determined based upon the Environmental Inspector's review of the accepted stormwater management plan and report and an evaluation using the impact scoring sheet. Utilizing the impact level approach, sites determined to have potential higher impacts will be inspected more often than the lower impact sites. Currently, sites with a high impact score are routinely inspected once every month, sites with a medium impact score are routinely inspected once every other month (or bi-monthly) and sites with a low impact score are routinely inspected once every three months (or once per quarter). However, inspection frequency may increase as a result of the need for follow-up inspections in response to site conditions observed during a routine inspection. Any routine site inspection that results in the identification of violations/deficiencies resulting from improperly maintained, installed or missing BMPs will require a follow-up inspection. At the conclusion of any routine or follow-up inspection where non-compliance is observed, the inspector will instruct the Permittee to correct the noted violations/deficiencies immediately, but in no event later than two (2) business days after the date of notification. The City will conduct follow-up inspections after the expiration of the two (2) business day period, but no later than five (5) business days after the date of the inspection. If a Permittee provides written and photo documentation within two (2) business days that the deficiencies have been corrected and the remediation is found to be adequate, the City reserves the right to consider this an appropriate follow-up and may return the site to routine inspection status. However, should the Permittee be unable to provide this documentation within two (2) business days, or if the documentation is found to be inadequate, the City will continue to conduct follow-up inspections at least once every five (5) business days, though more stringent actions, e.g. issuance of notice of violation or stop work order, may occur in the interim.

If any particular BMP is identified as needing maintenance during at least four (4) routine and/or follow-up inspections, the City reserves the right to increase the status of the BMP from maintenance to a violation. Once a maintenance item has been identified as a violation, it will continue to be identified as a violation during subsequent inspections and may be subject to the issuance of an NOV and/or SWO in accordance with the procedures listed below.

Procedures for Issuance of Notice of Violation (NOV) &/or Stop Work Order (SWO)

For sites being inspected monthly:

- Any permitted site receiving three (3) non-compliant inspections, regardless of whether the inspection is routine or follow-up, identifying the same violation(s) within a rolling six (6) months will be issued a first notice of violation (NOV).
- Any permitted site receiving four (4) non-compliant inspections, regardless of whether the inspection is routine or follow-up, identifying the same violation(s) within a rolling six (6) months will be issued a second notice of violation (NOV).
- Any permitted site receiving five (5) non-compliant inspections, regardless of whether the inspection is routine or follow-up, identifying the same violation(s) within a rolling six (6) months will be issued a stop work order (SWO),

For sites being inspected bi-monthly:

- Any permitted site receiving three (3) non-compliant inspections, regardless of whether the inspection is routine or follow-up, identifying the same violation(s) within a rolling nine (9) months will be issued a first notice of violation (NOV).
- Any permitted site receiving four (4) non-compliant inspections, regardless of whether the inspection is routine or follow-up, identifying the same violation(s) within a rolling nine (9) months will be issued a second notice of violation (NOV).
- Any permitted site receiving five (5) non-compliant inspections, regardless of whether the inspection is routine or follow-up, identifying the same violation(s) within a rolling nine (9) months will be issued a stop work order (SWO),

For sites being inspected quarterly:

- Any permitted site receiving two (2) non-compliant inspections, regardless of whether the inspection is routine or follow-up, identifying the same violation(s) within a rolling twelve (12) months will be issued a first notice of violation (NOV).
- Any permitted site receiving three (3) non-compliant inspections, regardless of whether the inspection is routine or follow-up, identifying the same violation(s) within a rolling twelve (12) months will be issued a second notice of violation (NOV).
- Any permitted site receiving four (4) non-compliant inspections, regardless of whether the inspection is routine or follow-up, identifying the same violation(s) within a rolling twelve (12) months will be issued a stop work order (SWO),

Notice of Violation (NOV)

The Notice of Violation will be issued to the Permittee within three (3) business days of the non-compliant inspection requiring the NOV and a follow-up inspection shall be conducted within five (5) business days of the issuance of Notice of Violation. The Permittee shall be notified via email followed by a hard copy of the report sent through the mail.

Stop Work Orders (SWO)

Stop Work Orders shall be issued by the Manager of Environmental Compliance or their designee. Stop Work Orders require the Permittee to cease all construction efforts for the site with the exception of erosion and sediment control implementation. A Stop Work Order shall remain in effect until the violation(s) has/have been corrected to the satisfaction of the Director of Water or their designee. In instances where the Stop Work Order is the result of not obtaining a permit, the SWO shall remain in effect until the

owner and/or contractor has obtained and/or executed the City's stormwater (quality) permit. In accordance with City Code, the SWO prohibits any construction activity except for such work that has been identified as necessary to correct the violation(s)/deficiency(s).

Depending upon the severity and magnitude of the violation(s), the above processes may be escalated and/or the inspection frequency increased. Sites whose inspection frequency is increased will then be subject to the escalation procedure associated with that inspection frequency. However, under the following circumstances the City's response shall automatically be escalated: identified illicit discharge, identified off-site release and/or a site operating without a City of Aurora Stormwater (Quality) Permit.

Illicit Discharge

The City shall issue the Permittee a Notice of Violation (NOV) accompanied by an Immediate Clean Up Order (ICO) within two (2) business days following any inspection (routine or follow-up) during which an illicit discharge is identified and directly attributable to a specific construction site. The Permittee will be notified via email followed by a hard copy of the report sent through the mail. The NOV and ICO will require the Permittee to immediately address the illicit discharge and take such steps as necessary to prevent a future discharge. The City shall conduct a follow-up inspection to the ICO and NOV no later than two (2) business days following the issuance of the NOV and ICO. If the illicit discharge has not been addressed by the onset of the follow-up inspection, the City shall issue the Permittee a Stop Work Order. The City may elect to shorten the City's response depending upon the severity, impact and/or location of the illicit discharge.

Off-site Release

The City shall issue the Permittee a Notice of Violation (NOV), which may include an Immediate Clean Up Order (ICO), within three (3) business days following any inspection (routine or follow-up) during which an off-site release is identified and directly attributable to a specific construction site. This notification will be sent via email followed by a hard copy of the report sent through the mail. The NOV will require the Permittee to immediately address the off-site release and to take measures to prevent similar instances from occurring in the future. The City will conduct a follow-up inspection as a result of the NOV no later than two (2) business days following the issuance of the NOV/ICO. If the off-site release has not been addressed by the onset of the follow-up inspection, the City shall issue the Permittee a second NOV within two (2) business days. The second NOV will require the Permittee to immediately address the off-site release and to take measures to prevent similar instances from occurring in the future. The City will conduct a follow-up inspection as a result of the second NOV no later than two (2) business days following the issuance of the second NOV. Again the issuance of enforcement action will be done via email followed by a hard copy of the report sent through the mail. If the off-site release has not been addressed by the onset of the second follow-up inspection, the City shall issue the Permittee a Stop Work Order. The City may elect to shorten the City's response depending upon the severity, impact and/or location of the off-site release.

Operating Without a City of Aurora Stormwater (Quality) Permit

Should a construction site disturbing one acre of land or more or disturbing less than an acre and part of a larger common plan of development be discovered to have begun construction and/or overlot grading without first obtaining and/or executing a City of Aurora Stormwater (Quality) Permit, the City shall issue the contractor and/or owner a NOV within two (2) business days for operating without a permit. The owner and/or contractor will be notified of the NOV via email followed by a hard copy of the report sent through the mail. The NOV will require the site to immediately address the items documented in the NOV. The City shall conduct a follow-up inspection to the NOV no later than two (2) business days following the issuance of the NOV. If the City is unable to execute the permit after the follow-up inspection has been conducted, the City shall issue the owner and/or contractor a Stop Work Order. The City may elect to shorten the City's response depending upon the severity, impact and/or location of the construction activity.

In addition, if a site has previously been issued a Stop Work Order and any inspection (routine or follow-up) during the ensuing four (4) months following the lifting of the SWO results in similar violation(s) being identified that necessitated the SWO, the City will take additional enforcement action, which may include an additional Stop Work Order, a revocation of the Permittee's City Stormwater (Quality) Permit or instituting criminal proceedings as authorized by law. When determining whether or not to revoke a permit, the City shall evaluate the egregiousness and severity of the violation(s). If the City decides to revoke a Stormwater (Quality) Permit, a revocation letter shall be supplied to the Permittee in writing (email notification is acceptable) within two (2) business days of the determination, at which point the site must cease all construction activities. In these instances, the City may be forced to correct the deficiencies themselves and to draw against the contractors/owners fiscal security that was deposited at the onset of the project.

Fiscal Security

The City will require all construction sites that begin construction after January 1, 2010 to post a fiscal security deposit per the "The City of Aurora Rules and Regulations Regarding Stormwater (Quality) Discharge for Construction Activities" that will be drawn against when the City is forced into completing repairs and/or conducting maintenance on existing construction site BMPs. The City reserves the right to draw against a site's fiscal security deposit/bond under the following circumstances: 1) the site has been abandoned or completed construction and it becomes necessary for the City to remove BMPs; 2) the site is unsuccessful at achieving final stabilization; 3) a site has been abandoned and it becomes necessary for the City to complete site stabilization and control measures to prevent additional erosion; 4) the site is not found to be properly addressing citizen complaints associated with noncompliance; 5) following permit revocation; 6) following the issuance of a stop work order; 7) following the issuance of an immediate clean up order; and, other instances where the City must complete work to ensure the City's storm system is properly protected against construction site run-off.

Withholding of City Services, Revocation of Permit, Environmental Hold & Property Lien

These are additional components of the City's Enforcement Escalation Policy and shall be reviewed and implemented on a case by case basis. The Permittees shall be notified when proceedings begin for any of these enforcement actions.

City of Aurora Stormwater (Quality) Rules and Regulations
Enforcement Escalation Policy
10/30/09

Escalation/Enforcement Type	Notice of Violation (NOV)	Stop Work Order (SWO)/ Suspension of Permit	Immediate Clean Up Order (ICO)	Withhold City Services	Revocation of Permit	Use of Fiscal Security	Property Lien
When will Enforcement Escalation be issued?	<ul style="list-style-type: none"> • The site receives three (3) non-compliant inspections within six (6) months /receives a routine inspection citing the same non-compliant concern(s) noted in previous inspections. • The site receives three (3) citizen complaints. • The site has an off-site release occur into a conveyance or waters of the state. • The site receives a failing NOV release inspection. • The site begins construction without an executed City of Aurora Stormwater Quality Permit. • An illicit discharge from the site to a conveyance feature to the MS4 system or into a waters of the state. • The site is non-compliant in the implementation of and the maintenance of the permit requirements. 	<ul style="list-style-type: none"> • The site has an off-site release occurring into a conveyance or waters of the state and/or more than once during the life of the project. • The site receives three (3) citizen complaints and no action has been taken to address the complaint. • An illicit discharge from the site to a conveyance feature to the MS4 system or into a waters of the state. • Operating without a City of Aurora approved plan set. • The site begins construction without an executed City of Aurora Stormwater Quality Permit. • The site receives a routine inspection citing the same non-compliant concern(s) noted in previous inspections. • The site receives two (2) NOV's within six (6) months. • The site receives three (3) NOV's within the duration of the construction project. 	<ul style="list-style-type: none"> • Construction activities have impacted a conveyance to or direct impact to a waters of the state with either equipment or pollutants. The nature of the release requires immediate remediation to prevent water quality impacts. • An illicit discharge from the site to a conveyance feature to the MS4 system and/or into a waters of the state. 	<ul style="list-style-type: none"> • The site receives two (2) NOV's within six (6) months. • The site receives three (3) NOV's within the duration of the construction project. 	<ul style="list-style-type: none"> • The site receives three (3) NOV's within the duration of the construction project. • To be addressed on an annual basis. At renewal time if it is determined that the permittee has been out of compliance more than 50% of the time based on City of Aurora documentation, the permit shall not be renewed. 	<ul style="list-style-type: none"> • The site does not remove Best Management Practices (BMPs). • Citizen complaints that are not addressed. • Chronic and recalcitrant in addressing the remediation causing City of Aurora Personnel to address the problem area(s). • Fiscal security shall be utilized if the owner/developer goes bankrupt. • Fiscal security shall be utilized if SWO issued and no erosion control measures are addressed or the contractor leaves the job site. • Fiscal security shall be utilized if final stabilization has not yet been achieved and permittee does not complete remediation/implementation. 	<ul style="list-style-type: none"> • The site does not remove BMP's. • Citizen complaints are not addressed. • Chronic and recalcitrant in addressing the remediation causing City of Aurora Personnel to go and address the problem area.
	<ul style="list-style-type: none"> • NOV's shall be required to be addressed immediately with documentation 	<ul style="list-style-type: none"> • A Stop Work Order shall be in effect until the site is brought into compliance and passes 	<ul style="list-style-type: none"> • Immediate Clean Up Orders shall be addressed immediately and completed within 	<ul style="list-style-type: none"> • Permittee will be required to maintain site in compliance at all times and additional 	<ul style="list-style-type: none"> • Permittee shall be required to resubmit revised plans for approval through plans 	<ul style="list-style-type: none"> • To be addressed on a case by case basis with permittee. • Permittee shall be notified 	<ul style="list-style-type: none"> • To be addressed on a case by case basis with permittee.

Appendix C – Reserved

This Appendix is reserved for future use.

THIS PAGE IS INTENTIONALLY BLANK

Appendix D – City of Aurora Standard Details for Temporary BMP Installation During Construction

The City of Aurora details provided here are to be referenced but not re-printed on the SWMP drawings unless project-specific modifications to these details are proposed.

THIS PAGE IS INTENTIONALLY BLANK

SYMBOL	TITLE	# pages
Ⓢ	CHECK DAM	2
Ⓢ	CONSTRUCTION FENCE	2
Ⓢ / Ⓢ	COMPOST FILTER BERM/COMPOST BLANKET	4
Ⓢ	CURB SOCK	2
Ⓢ / Ⓢ	CONCRETE WASHOUT & SMALL SITE CONCRETE/LIQUID WASTE WASHOUT	4
Ⓢ	DIVERSION CHANNELS	6
Ⓢ	TEMPORARY DIVERSION DIKE/DITCH/BERM	2
Ⓢ	DEWATERING	4
Ⓢ	EROSION CONTROL BLANKET	4
Ⓢ	AREA INLET PROTECTION	3
Ⓢ	CULVERT INLET PROTECTION	2
Ⓢ	INTERIM INLET PROTECTION	2
Ⓢ	ON-GRADE INLET PROTECTION	2
Ⓢ	SUMP INLET PROTECTION	2
Ⓢ	SINGLE FAMILY LOT EROSION CONTROL BMPS	11
Ⓢ	MATERIALS STAGING IN ROADWAY	2
Ⓢ	TEMPORARY OUTLET PROTECTION	2
Ⓢ	REINFORCED CHECK DAM	1
Ⓢ	ROUGH CUT STREET CONTROL	2
Ⓢ	ROCK SOCKS/WATTLES	2
Ⓢ	SEDIMENT BASIN	4
Ⓢ	SEDIMENT CONTROL LOG	2
Ⓢ	SILT FENCE	2
Ⓢ-R	SILT FENCE - REINFORCED	2
Ⓢ	SEEDING AND MULCHING	7
Ⓢ	SURFACE ROUGHENING	4
Ⓢ	STABILIZED STAGING AREA	2
Ⓢ	SEDIMENT TRAP	2
Ⓢ	TEMPORARY STREAM CROSSING	2
Ⓢ	TEMPORARY SLOPE DRAIN	2
Ⓢ	VEHICLE TRACKING CONTROL	2
Ⓢ	VTC WITH WHEEL WASH	2

THIS PAGE IS INTENTIONALLY BLANK

STANDARD

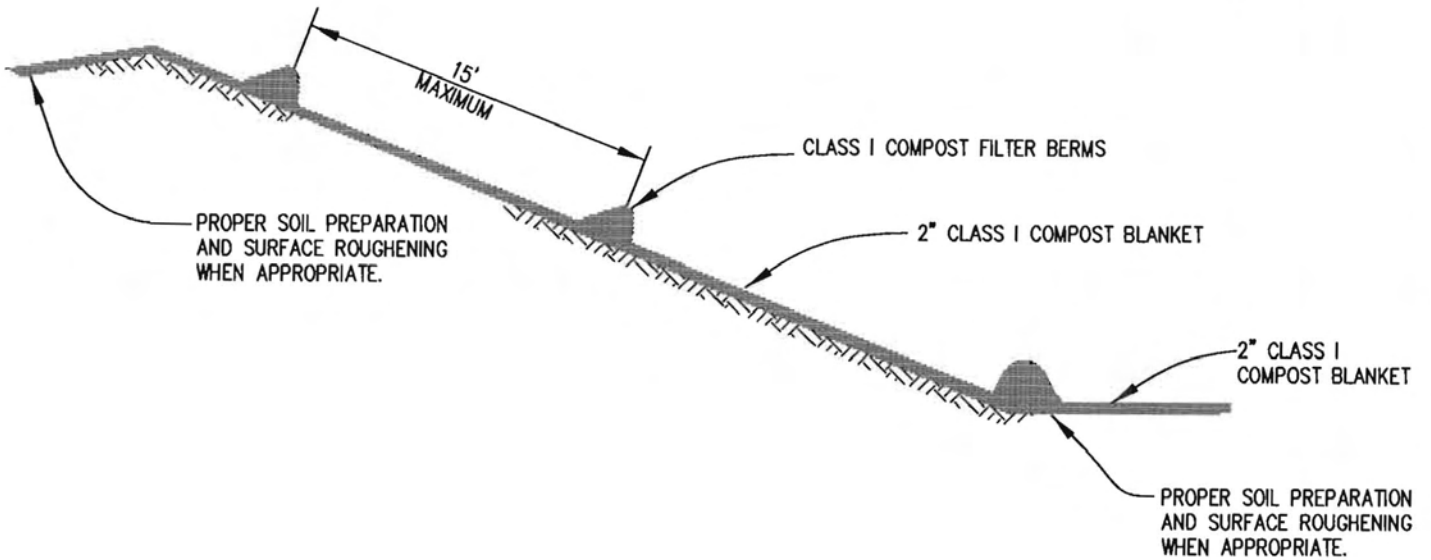
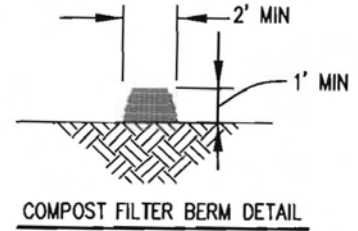
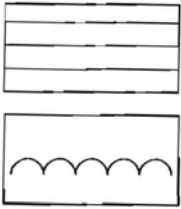

SOURCE: ADAPTED FROM
DOUGLAS COUNTY GESC
STANDARD DETAILS

CITY OF AURORA, COLORADO

Chris [Signature]
AURORA WATER DEPARTMENT

11/2/10
DATE

Shirley [Signature]
CITY ENGINEER

1.14.10
DATE

COMPOST FILTER BERM &
COMPOST BLANKET

1 OF 4



STANDARD

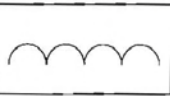



1. SEE PLAN VIEW FOR LENGTH OF COMPOST FILTER BERM.
2. SHALL BE APPLIED TO ALL SLOPES RECEIVING A COMPOST BLANKET AT 15' INCREMENTS.
3. FILTER BERMS SHALL RUN PARALLEL TO THE CONTOUR.
4. FILTER BERMS SHALL BE A MINIMUM OF 1' H X 2' W.
5. FILTER BERMS SHALL BE APPLIED UTILIZING PNEUMATIC BLOWER, OR BY HAND.
6. SHALL ONLY BE UTILIZED IN AREAS WHERE SHEET FLOW CONDITIONS PREVAIL; SHALL BE PROHIBITED IN AREAS OF POSSIBLE CONCENTRATED FLOW.
7. SOIL PREPARATION SHALL BE COMPLETE PER THE SPECIFICATIONS OUTLINED IN THESE CRITERIA PRIOR TO APPLICATION.
8. WHEN TURF GRASS FINISH IS NOT DESIRED, SURFACE ROUGHENING OF SLOPES SHALL TAKE PLACE PRIOR TO APPLICATION.
9. SEEDING SHALL BE DRILLED PRIOR TO THE APPLICATION OF COMPOST OR SEED MAY BE COMBINED AND BLOWN WITH THE PNEUMATIC BLOWER.
10. COMPOST USED IN THE APPLICATION OF THE COMPOST BLANKET SHALL BE A CLASS I COMPOST AS DEFINED BY THE FOLLOWING PHYSICAL, CHEMICAL, AND BIOLOGICAL PARAMETERS.
11. COMPOST FILTER BERM SHALL BE UTILIZED ON SLOPES WITH MAXIMUM SPACING OF 15 FEET PER THE REQUIREMENTS FOUND IN THE COMPOST FILTER BERM SECTION.

PARAMETERS	CLASS I COMPOST FOR COMPOST FILTER BERM
MINIMUM STABILITY INDICATOR	STABLE TO VERY STABLE
SOLUBLE SALTS	MAXIMUM 5MMHOS/OM
PH	6.0-8.0
AG INDEX	> 10
MATURITY INDICATOR EXPRESSED AS PERCENTAGE OF GERMINATION/VIGOR	80+/80+
MATURITY INDICATOR EXPRESSED AS AMMONIA N/ NITRATE N RATIO	< 4
MATURITY INDICATOR EXPRESSED AS CARBON TO NITROGEN RATIO	20:1
TESTED FOR CLOPYRALID	YES/NEGATIVE RESULT
MOISTURE CONTENT	30-60%
ORGANIC MATTER CONTENT	25-45% OF DRY WEIGHT
PARTICLE SIZE DISTRIBUTION	3" (75MM) 100% PASSING 1" (25MM) 95% TO 100% PASSING 3/4" (19MM) 85% TO 90% PASSING 3/8" (9.5MM) 50% TO 60% PASSING #4 20 TO 35% PASSING
PRIMARY, SECONDARY NUTRIENTS: TRACE ELEMENTS	MUST BE REPORTED
TESTING AND TEST REPORT SUBMITTAL REQUIREMENTS	STA + CLOPYRALID
ORGANIC MATTER PER CUBIC YARD	MUST REPORT
CHEMICAL CONTAMINANTS	MEET OR EXCEED US EPA CLASS A STANDARD, 40CFR 503.1 TABLES 1 & 3 LEVELS
MINIMUM MANUFACTURING/PRODUCTION REQUIREMENT	FULLY PERMITTED UNDER COLORADO DEPARTMENT OF PUBLIC HEALTH AND ENVIRONMENT, HAZARDOUS MATERIALS AND WASTE MANAGEMENT DIVISION
RISK FACTOR RELATING TO PLANT GERMINATION AND HEALTH	LOW

NOTE: IF A BIOSOLID COMPOST IS TO BE UTILIZED IT SHALL BE PRODUCED BY A FACILITY IN POSSESSION OF A VALID NOTICE OF AUTHORIZATION (NOA) FOR THE UNRESTRICTED USE AND DISTRIBUTION BY THE COLORADO DEPARTMENT OF PUBLIC HEALTH AND ENVIRONMENT. THE NOA SHALL BE PROVIDED UPON REQUEST TO THE CITY OF AURORA.

SOURCE: ADAPTED FROM DOUGLAS COUNTY GESC STANDARD DETAILS

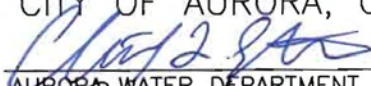
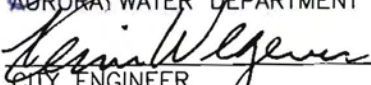
NOTE: A LAB TEST DETAILING THE CHEMICAL, PHYSICAL, AND BIOLOGICAL PARAMETERS SHALL BE PROVIDED UPON REQUEST TO CITY OF AURORA.

CITY OF AURORA, COLORADO  AURORA WATER DEPARTMENT  CITY ENGINEER	1/12/10 DATE 1/14/10 DATE	COMPOST FILTER BERM	2 OF 4 
--	------------------------------------	------------------------	---

STANDARD

1. SEE PLAN VIEW FOR AREA OF COMPOST BLANKET.
2. MAY BE USED IN PLACE OF STRAW MULCH OR EROSION CONTROL BLANKET IN AREAS WHERE ACCESS IS DIFFICULT DUE TO LANDSCAPING OR OTHER OBJECTS OR IN AREAS WHERE A SMOOTH TURF GRASS FINISH IS DESIRED.
3. SHALL ONLY BE UTILIZED IN AREAS WHERE SHEET FLOW CONDITIONS PREVAIL:
SHALL BE PROHIBITED IN AREAS OF POSSIBLE CONCENTRATED FLOW.
4. SOIL PREPARATION SHALL BE COMPLETE PER THE SPECIFICATIONS OUTLINED IN THESE CRITERIA PRIOR TO APPLICATION.
5. WHEN TURF GRASS FINISH IS NOT DESIRED, SURFACE ROUGHENING OF SLOPES SHALL TAKE PLACE PRIOR TO APPLICATION.
6. SHALL BE EVENLY APPLIED AT A DEPTH OF 2 INCHES.
7. MAY BE APPLIED UTILIZING PNEUMATIC BLOWER, OR BY HAND.
8. SEEDING SHALL BE DRILLED PRIOR TO THE APPLICATION OF COMPOST OR SEED. MAY BE COMBINED AND BLOWN WITH THE PNEUMATIC BLOWER.
9. COMPOST USED IN THE APPLICATION OF THE COMPOST BLANKET SHALL BE CLASS I COMPOST AS DEFINED BY THE FOLLOWING PHYSICAL, CHEMICAL, AND BIOLOGICAL PARAMETERS.

PARAMETERS	CLASS I COMPOST FOR COMPOST BLANKET
MINIMUM STABILITY INDICATOR	STABLE TO VERY STABLE
SOLUBLE SALTS	MAXIMUM 5MMHOS/OM
PH	6.0-8.0
AG INDEX	> 10
MATURITY INDICATOR EXPRESSED AS PERCENTAGE OF GERMINATION/VIGOR	80+/80+
MATURITY INDICATOR EXPRESSED AS AMMONIA N/ NITRATE N RATIO	< 4
MATURITY INDICATOR EXPRESSED AS CARBON TO NITROGEN RATIO	20:1
TESTED FOR CLOPYRALID	YES/NEGATIVE RESULT
MOISTURE CONTENT	30-60%
ORGANIC MATTER CONTENT	25-45% OF DRY WEIGHT
PARTICLE SIZE DISTRIBUTION	3" (75MM) 100% PASSING 1" (25MM) 95% RO 100% PASSING 3/4" (19MM) 85% TO 90% PASSING 3/8" (9.5MM) 50% TO 60% PASSING #4 20 TO 35% PASSING
PRIMARY, SECONDARY NUTRIENTS: TRACE ELEMENTS	MUST BE REPORTED
TESTING AND TEST REPORT SUBMITTAL REQUIREMENTS	STA + CLOPYRALID
ORGANIC MATTER PER CUBIC YARD	MUST REPORT
CHEMICAL CONTAMINANTS	MEET OR EXCEED US EPA CLASS A STANDARD, 40CFR 503.1 TABLES 1 & 3 LEVELS
MINIMUM MANUFACTURING/PRODUCTION REQUIREMENT	FULLY PERMITTED UNDER COLORADO DEPARTMENT OF PUBLIC HEALTH AND ENVIRONMENT, HAZARDOUS MATERIALS AND WASTE MANAGEMENT DIVISION
RISK FACTOR RELATING TO PLANT GERMINATION AND HEALTH	LOW

SOURCE: ADAPTED FROM DOUGLAS COUNTY GESC STANDARD DETAILS

NOTES: CLOPYRALID IS THE COMMON NAME OF A HERBICIDE THAT KILLS BROAD-LEAVED WEEDS SUCH AS DANDELIONS, CLOVER AND THISTLE.

<p>CITY OF AURORA, COLORADO</p> <p><i>Chad 29/A</i> 11/2/10 AURORA WATER DEPARTMENT DATE</p> <p><i>Kevin Wegener</i> 1.14.10 CITY ENGINEER DATE</p>	<h2 style="margin: 0;">COMPOST BLANKET</h2>	<p>3 OF 4</p> <div style="border: 1px solid black; border-radius: 50%; width: 60px; height: 60px; margin: 0 auto; display: flex; align-items: center; justify-content: center;"> CB </div>
---	---	---

STANDARD

Compost Blanket - consists of a layer of Class I Compost spread over prepared, seeded topsoil to protect exposed soil against raindrop and wind erosion and to provide an organic soil amendment to promote revegetation. This COA-accepted BMP can be considered as an alternative to an erosion control blanket or crimped mulch for stabilizing exposed soils, although it should not be used in drainageways or concentrated flow areas.

Key Installation and Maintenance Requirements:

- Compost blankets should only be used in areas where limited sheet flow conditions are customary and should not be applied in areas of possible concentrated flows



Care needs to be exercised during installation to ensure that compost material does not enter watercourses or drainageways.

CITY OF AURORA, COLORADO

Chris 25th 11/21/10
AURORA WATER DEPARTMENT DATE

Kevin Wegener 1.14.10
CITY ENGINEER DATE

COMPOST
BLANKET

4 OF 4



STANDARD ROCK CHECK DAM

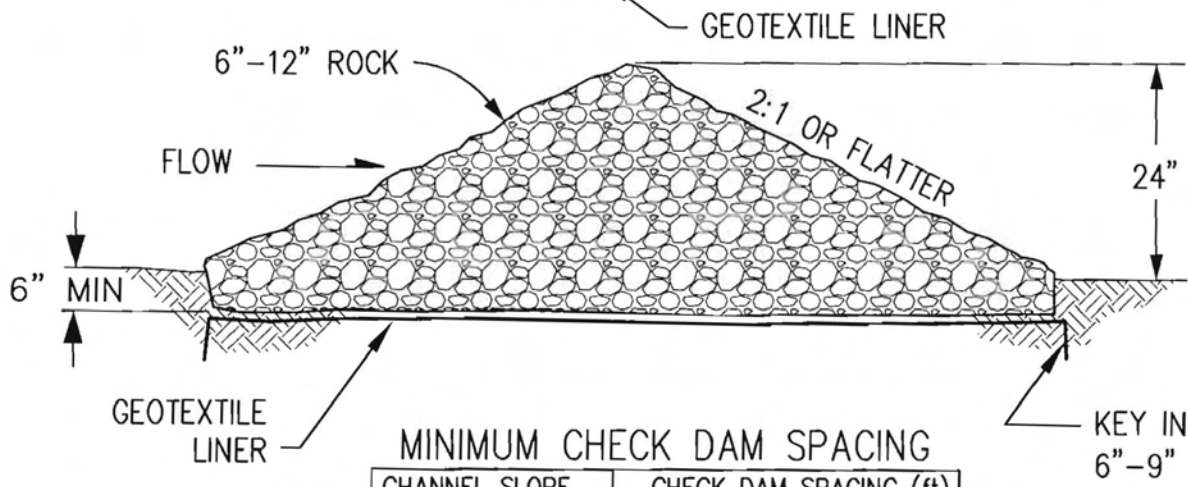
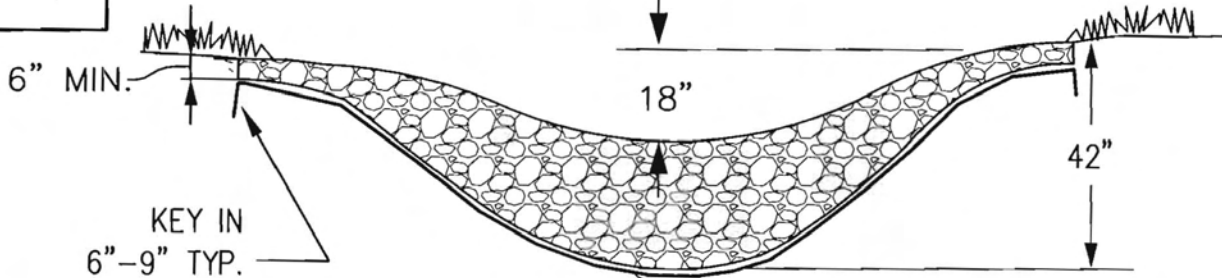

MINIMUM CHECK DAM SPACING

CHANNEL SLOPE	CHECK DAM SPACING (ft)
0.5%	800
1.0%	400
2.0%	200
3.0%	133
4.0%	100
5.0%	80
6.0%	67
7.0%	57
8.0%	50
9.0%	44
10.0%	40

NOTE: SLOPE GREATER THAN
10% REQUIRES ALTERNATE
METHODS (IE. TEMP SLOPE DRAIN)

NOTES

1. CHECK DAMS INDICATED ON INITIAL PLAN SHALL BE INSTALLED AFTER CONSTRUCTION FENCE, BUT PRIOR TO ANY UPSTREAM LAND DISTURBING ACTIVITIES.
2. RIPRAP UTILIZED FOR CHECK DAMS SHALL HAVE A D₅₀ MEDIAN STONE SIZE OF 6"-12".
3. RIPRAP PAD SHALL BE TRENCHED INTO THE GROUND A MINIMUM OF 6".
4. THE ENDS OF THE CHECK DAM SHALL BE A MINIMUM OF 1'-6" HIGHER THAN THE CENTER OF THE CHECK DAM.
5. SEDIMENT ACCUMULATED UPSTREAM OF THE CHECK DAMS SHALL BE REMOVED WHEN THE SEDIMENT DEPTH IS WITHIN 1/3 OF THE HEIGHT OF THE CREST.
6. CHECK DAMS ARE TO REMAIN IN PLACE UNTIL THE UPSTREAM DISTURBED AREA IS STABILIZED AND GRASS COVER IS APPROVED BY THE CITY.
7. WHEN CHECK DAMS ARE REMOVED, EXCAVATIONS SHALL BE FILLED WITH SUITABLE COMPACTED BACK FILL. ANY DISTURBED AREA SHALL BE SEEDED AND MULCHED AND COVERED WITH EROSION CONTROL BLANKET OR OTHERWISE STABILIZED IN A MANNER APPROVED BY THE CITY.
8. NOT SUITABLE FOR AREAS WITH MORE THAN 10 ACRES OF TRIBUTARY DRAINAGE AREA.

CITY OF AURORA, COLORADO

[Signature] 1/12/10
 AURORA WATER DEPARTMENT DATE
[Signature] 1.14.10
 CITY ENGINEER DATE

CHECK DAM

1 OF 2



STANDARD

Check Dam - a rock dam, designed to withstand overtopping, that is constructed in a drainage swale, or ditch. The function of the check dam is to reduce flow velocities to minimize ditch cutting.

Key Installation and Maintenance Requirements:

- Recycled or demolished concrete material or straw bales are not acceptable substitutes for rock
- When used in a series, the top of the lower dam should be at the same topographical elevation as the toe of the upper dam
- These features need to be proactively maintained in a continuously operational state. They are not considered to be functional when debris or sediment accumulation compromises the effectiveness of the feature
- Other features or materials may be substituted for rock, upon review and approval by COA. Silt fencing is not appropriate for Check Dam installations.



Features need to be installed correctly and maintained in place to be functional. The features illustrated on the right have experienced erosion and by-pass due to incorrect installation.



CITY OF AURORA, COLORADO

Miss [Signature]
AURORA WATER DEPARTMENT

4/12/10
DATE

Kevin Wegner
CITY ENGINEER

1.14.10
DATE

CHECK DAM

2 OF 2



STANDARD

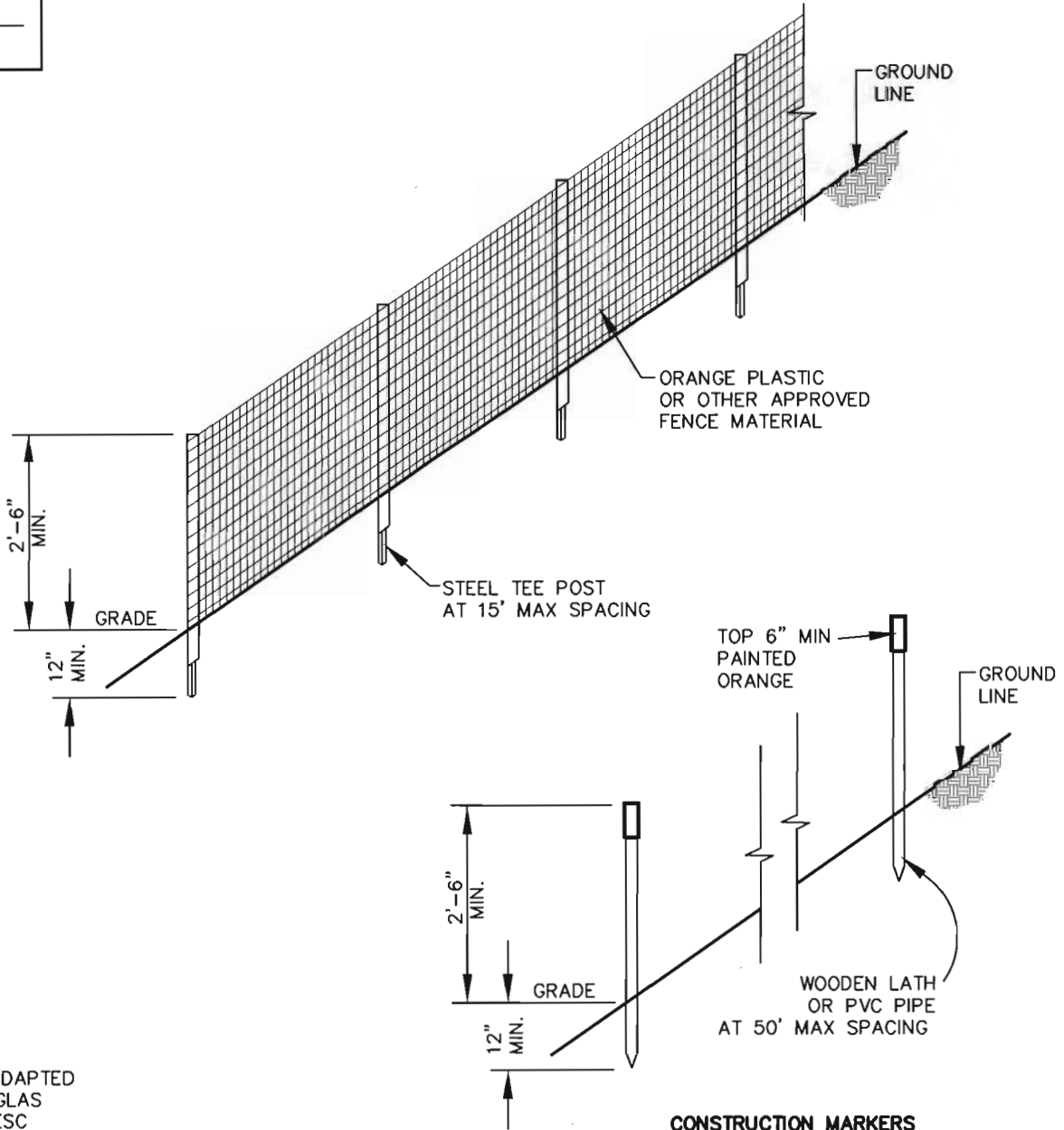
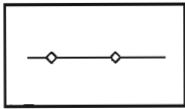

SOURCE: ADAPTED FROM DOUGLAS COUNTY GESC STANDARD DETAILS

CONSTRUCTION MARKERS (ALTERNATIVE TO CONSTRUCTION FENCE) BY VARIANCE ONLY

CONSTRUCTION FENCE INSTALLATION NOTES

1. SEE PLAN VIEW FOR:
 - TYPE OF CONSTRUCTION LIMIT INDICATOR (FENCE OR MARKERS).
 - LOCATION OF FENCE OR LINE OF MARKERS
2. CONSTRUCTION FENCE OR MARKERS INDICATED ON INITIAL PLAN SHALL BE INSTALLED PRIOR TO OTHER BMPS AND ANY LAND DISTURBING ACTIVITIES.
3. STEEL TEE POSTS SHALL BE UTILIZED FOR SUPPORT OF CONSTRUCTION FENCE. MAXIMUM SPACING FOR TEE POSTS SHALL BE 15'.
4. TO BE USED TO SEPARATE OR PROTECT AREAS OF NON-DISTURBANCE.
5. DO NOT INSTALL WITHIN DRIPLINE OF EXISTING TREES.

CITY OF AURORA, COLORADO

1 OF 2

Chris Z... 7/1/10
 AURORA WATER DEPARTMENT DATE
Sam Wejner 9.2.10
 CITY ENGINEER DATE

CONSTRUCTION FENCE



STANDARD

Construction Fence - consists of orange plastic fencing or other COA-accepted material attached to support posts and used to delineate the limits of construction and to control access to the construction site. If approved by the COA, construction markers, consisting of orange painted survey posts or stanchions installed at 50-foot maximum spacing, may be used to delineate the limits of construction, or to protect trees and other vegetation.



Features need to be maintained in good condition to be functional.



CITY OF AURORA, COLORADO

Chad S. ... 1/12/10
AURORA WATER DEPARTMENT DATE

Kevin W. Legner 1.14.10
CITY ENGINEER DATE

CONSTRUCTION FENCE

2 OF 2



STANDARD

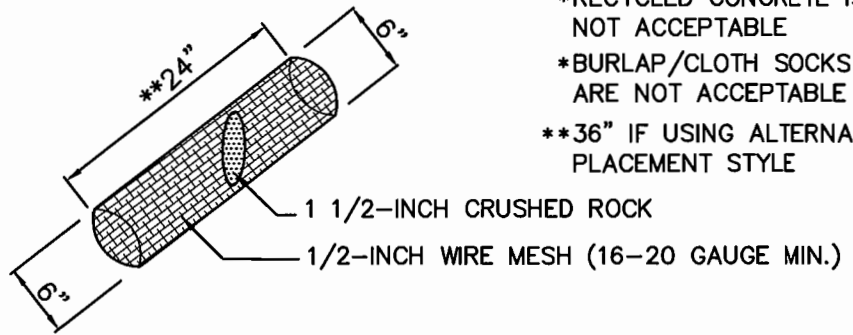
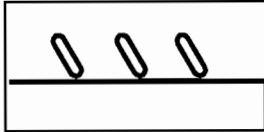

DETAIL 1

- *RECYCLED CONCRETE IS NOT ACCEPTABLE
- *BURLAP/CLOTH SOCKS ARE NOT ACCEPTABLE
- **36" IF USING ALTERNATIVE PLACEMENT STYLE

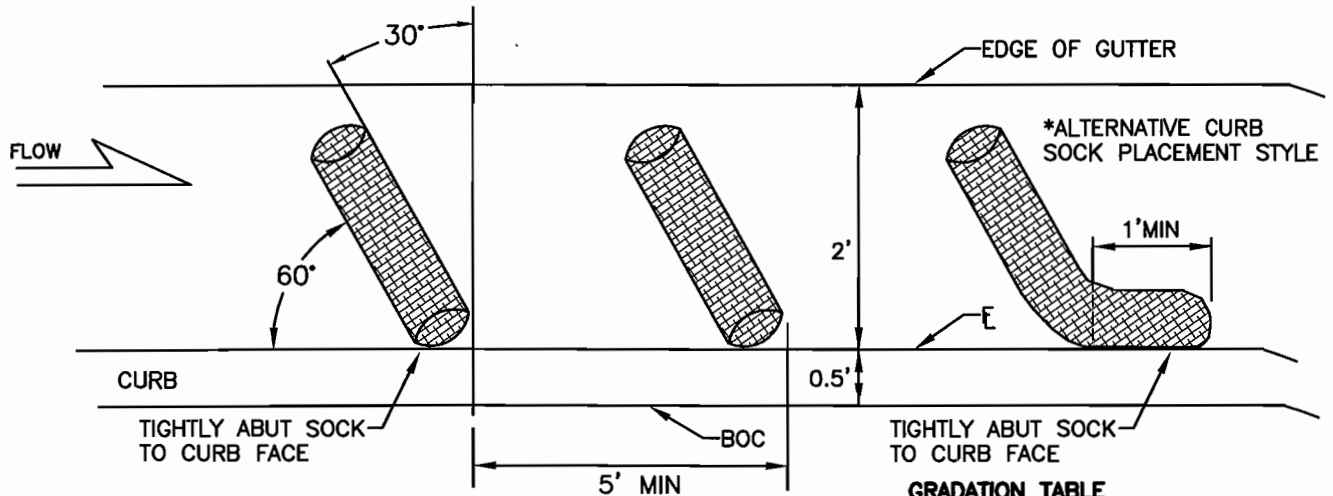

DETAIL 2

MAXIMUM SPACING ALONG STREET GRADE

STREET SLOPE	CURB SOCK SPACING (ft)
0.5%	100
1.0%	100
2.0%	75
3.0%	50
4.0%	50
5.0%	50
6.0%	25
7.0%	25
8.0%	25

GRADATION TABLE

SIEVE SIZE	MASS PERCENT PASSING SQUARE MESH SIEVES
	NO. 4
	100
2"	90 - 100
1 1/2"	20 - 55
1"	0 - 15
3/4"	0 - 5
3/8"	0 - 5

MATCHES SPECIFICATIONS FOR NO. 4 COARSE AGGREGATE FOR CONCRETE PER AASHTO M43. ALL ROCK SHALL BE FRACTURED FACE, ALL SIDES.

NOTES:

1. SOCKS WILL BE USED UPGRADIENT OF INLET ANGLED AS SHOWN AND SHALL BE FLUSH WITH CURB.
2. FOR IPS AND IPO NO LESS THAN THREE 6-INCH DIAMETER SOCKS MUST BE USED IN SEQUENCE, SPACED NO MORE THAN FIVE FEET APART, WHEN SHOWN ON PLAN.
3. INCLINE AT 30 DEGREES FROM PERPENDICULAR, OPPOSITE THE DIRECTION OF FLOW (SEE DETAIL 2).
4. A MINIMUM OF THREE CURB SOCKS SHALL BE PLACED DOWNSTREAM OF ANY DISTURBED AREA AND ALONG ALL CURBS FRONTING DISTURBED AREA, SPACED PER THE TABLE.
5. SOCKS WILL BE USED AT ANY LOCATION ALONG A CURB TO CONTROL SEDIMENT AS DIRECTED BY CITY.
6. 16-20 GAUGE CHICKEN WIRE IS AN ACCEPTABLE ALTERNATIVE IF DOUBLE WRAPPED WITH NO MORE THAN 1/2 INCH OPENINGS.

CITY OF AURORA, COLORADO
Wesley 11/5/10
 AURORA WATER DEPARTMENT DATE
Kevin Wegener 11.9.10
 CITY ENGINEER DATE

CURB SOCKS

1 OF 2

CS

STANDARD

Curb Sock - are installed as curbside check dams and are wire mesh wrapped rock wattles installed for sediment control. Typical installation is a series of socks on a grade in the curb flowline upstream of a curb inlet to filter sediment-laden runoff and reduce the velocity of the flow.

Key Installation and Maintenance Requirements:

- Curb socks shall be constructed such that the final product is a cylindrical shaped filter with ½ - inch mesh filled with 1½ - inch gravel
- Curb socks shall not exceed 24" in length, 6" in diameter and shall be placed at 60° angles in curb drainage flow lines flush with the curb. The spacing and quantity of the curb socks should be determined by the length and grade of the curb drainage flow line
- Install delineators with the curb socks for high traffic areas where installations present a potential traffic hazard or where they may be damaged by snow plowing activities
- Recycled or demolished concrete material is not an acceptable substitute for rock fill.
- Installed features need to be monitored for correct placement or rupture and adjusted, replaced or repaired as needed



Features are not appropriately spaced in this application. Upgradient erosion control measures need to be implemented to prevent heavy sediment loading. Curb socks are not designed to manage the amount of sediment removal depicted here.

CITY OF AURORA, COLORADO

Chris [Signature] 1/12/10
AURORA WATER DEPARTMENT DATE

Kevin Wegener 1.14.10
CITY ENGINEER DATE

CURB SOCKS

2 OF 2



STANDARD

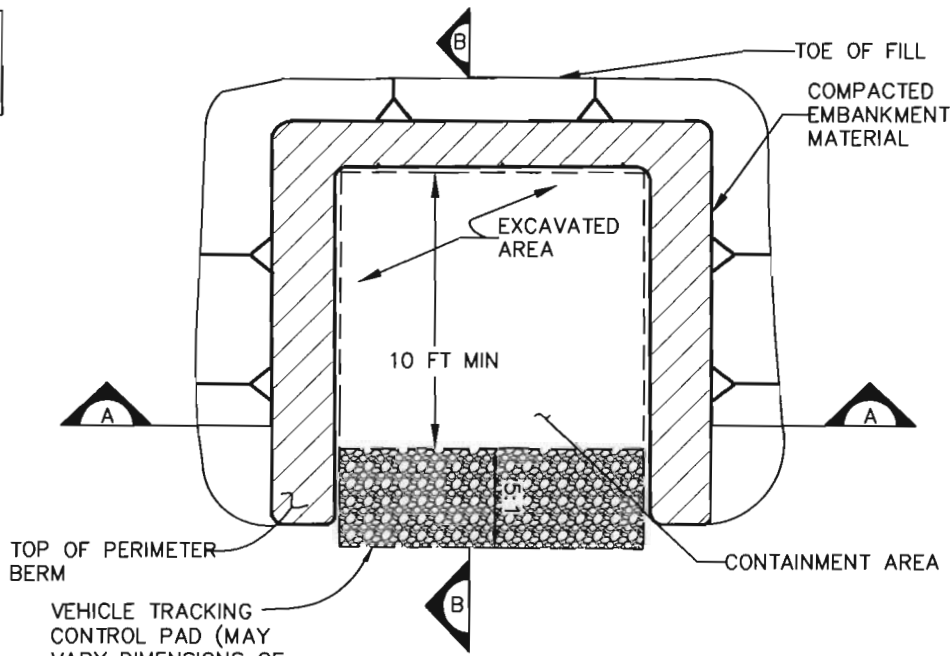
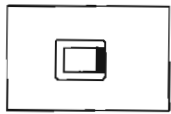

PLAN VIEW

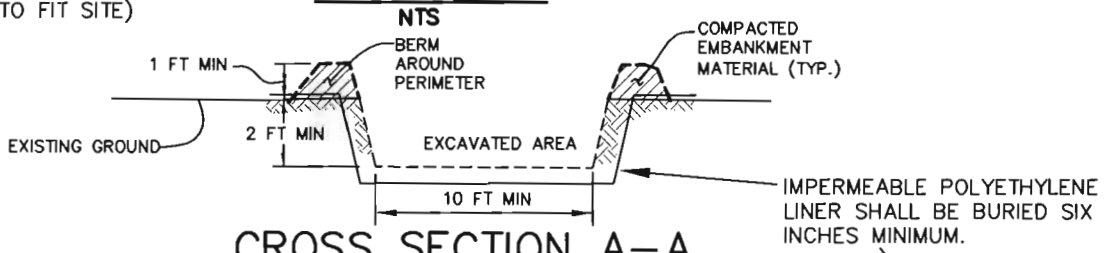

CROSS SECTION A-A

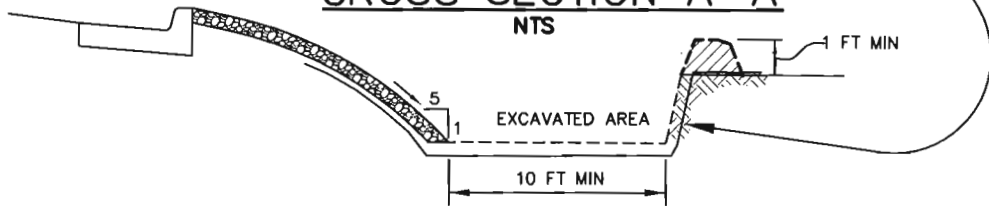

CROSS SECTION B-B

NOTES:

1. THE CONCRETE WASHOUT AREA SHALL BE INSTALLED PRIOR TO ANY CONCRETE PLACEMENT ON A PROJECT.
2. VEHICLE TRACKING CONTROL (VTC) IS REQUIRED AT THE ACCESS POINT.
3. SIGNS SHALL BE PLACED AT THE CONSTRUCTION ENTRANCE, AT THE WASHOUT AREA, AND ELSEWHERE AS NECESSARY TO CLEARLY INDICATE THE LOCATION OF THE CONCRETE WASHOUT AREA TO OPERATORS OF CONCRETE TRUCKS AND PUMP RIGS.
4. EXCAVATED MATERIAL SHALL BE UTILIZED IN PERIMETER BERM CONSTRUCTION.
5. THE CONCRETE WASHOUT AREA WILL BE REPAIRED, ENLARGED OR CLEANED OUT AS NECESSARY TO MAINTAIN CAPACITY FOR WASTE CONCRETE.
6. AT THE END OF CONSTRUCTION ALL CONCRETE SHALL BE REMOVED FROM THE SITE IN A WATERTIGHT CONTAINER AND DISPOSED OF AT AN APPROVED WASTE SITE.
7. WHEN THE CONCRETE WASHOUT AREA IS REMOVED, THE DISTURBED AREA SHALL BE DRILL SEEDDED AND CRIMP MULCHED OR OTHERWISE STABILIZED IN A MANNER APPROVED BY THE CITY.
8. CONDITIONS MAY WARRANT THE USE OF POLYETHYLENE LINER, AS DIRECTED BY THE CITY.
9. AT NO TIME SHALL LIQUID WASTES BE PUMPED OUT ONTO DISTURBED GROUND WITHOUT BEING CONTAINED OR, OUT OF THE WASHOUT AREA AND INTO THE STREET AND/OR STORM SEWER.
10. MANUFACTURED WASHOUT BINS ARE AN ALLOWABLE ALTERNATIVE. IMPLEMENT WITH A REDUNDANT BMP.
11. DO NOT CONSTRUCT WITHIN DRIPLINE OF EXISTING TREE.

CITY OF AURORA, COLORADO
Chris 25th 11/1/10
 AURORA WATER DEPARTMENT DATE
Kevin Wegener 9.2.10
 CITY ENGINEER DATE

CONCRETE WASHOUT

1 OF 4



STANDARD

CONCRETE WASHOUT – IS A DESIGNATED, SHALLOW EXCAVATION WITH A PERIMETER BERM TO CONTAIN WASTE FROM CONCRETE TRUCKS, SMALL BATCH CONCRETE MIXERS, PUMP TRUCKS, AND OTHER WASHOUT OPERATIONS. NO CONCRETE WASTE IS TO BE DISCHARGED FROM A DELIVERY TRUCK, PUMP TRUCK OR SMALL BATCH MIXER DIRECTLY ONTO THE GROUND OUTSIDE OF A DESIGNATED WASHOUT AREA. ALL CONCRETE WASTE AND WASHOUTS FROM DELIVERY TRUCKS, PUMP TRUCKS OR SMALL BATCH MIXERS ARE TO BE DISCHARGED DIRECTLY INTO DESIGNATED WASHOUT AREAS.

KEY INSTALLATION AND MAINTENANCE REQUIREMENTS:

- * MAINTAIN A MINIMUM DISTANCE OF 400 FEET FROM A DRAINAGEWAY, WATERWAY OR WATER BODY, OR INSTALL WITH AN IMPERMEABLE POLYETHYLENE LINER.
- * MAINTAIN A MINIMUM DISTANCE OF 1000 FEET FROM ANY WELLS OR DRINKING WATER SOURCE
- * DO NOT LOCATE IN A NATURAL DRAW OR DRAINAGE SWALE
- * DO NOT LOCATE IN AREAS OF HIGHLY PERMEABLE SOILS, I.E., GRAVELS AND SANDS, OR INSTALL WITH AN IMPERMEABLE POLYETHYLENE LINER.
- * BERMING AND OTHER PERIMETER CONTROLS SHOULD PROVIDE PROTECTION FROM SURFACE RUN-ON AS WELL AS CONTAINMENT OF LIQUID WASTES.
- * CONCRETE OR OTHER WASTE IS NOT TO BE ABANDONED ON-SITE. AT THE END OF CONSTRUCTION, ALL CONCRETE WASTE SHALL BE REMOVED FROM THE SITE AND DISPOSED OF AT AN APPROVED WASTE SITE.
- * THE CONCRETE WASHOUT AREA SHOULD NOT BE USED FOR THE STORAGE OR STOCKPILING OF CONSTRUCTION MATERIALS, INCLUDING WASTE CONCRETE FROM DEMOLITION ACTIVITIES.
- * BE AT LEAST 100 FEET AWAY FROM AN INLET OR ADDITIONAL REDUNDANT BMPs MAY BE REQUIRED.
- * DO NOT LOCATE IN AREAS WHERE THE EXISTING GRADE AND VEGETATION IS TO BE PRESERVED.
- * SHALL BE LOCATED SUCH THAT IF A FAILURE OR OVERTOPPING OCCURS, FLOW WOULD GO TO FLAT OR DEPRESSED VEGETATED AREAS, AWAY FROM THE DRAINAGES, CONVEYANCES, AND PAVED SURFACES.



Liquid waste from washout operations should not be discharged to paved sections or the ground without an adequate means of containment.

CITY OF AURORA, COLORADO

May 2 St 9/1/10
AURORA WATER DEPARTMENT DATE

Chris Wegener 9-2-10
CITY ENGINEER DATE

CONCRETE WASHOUT

2 OF 4



STANDARD

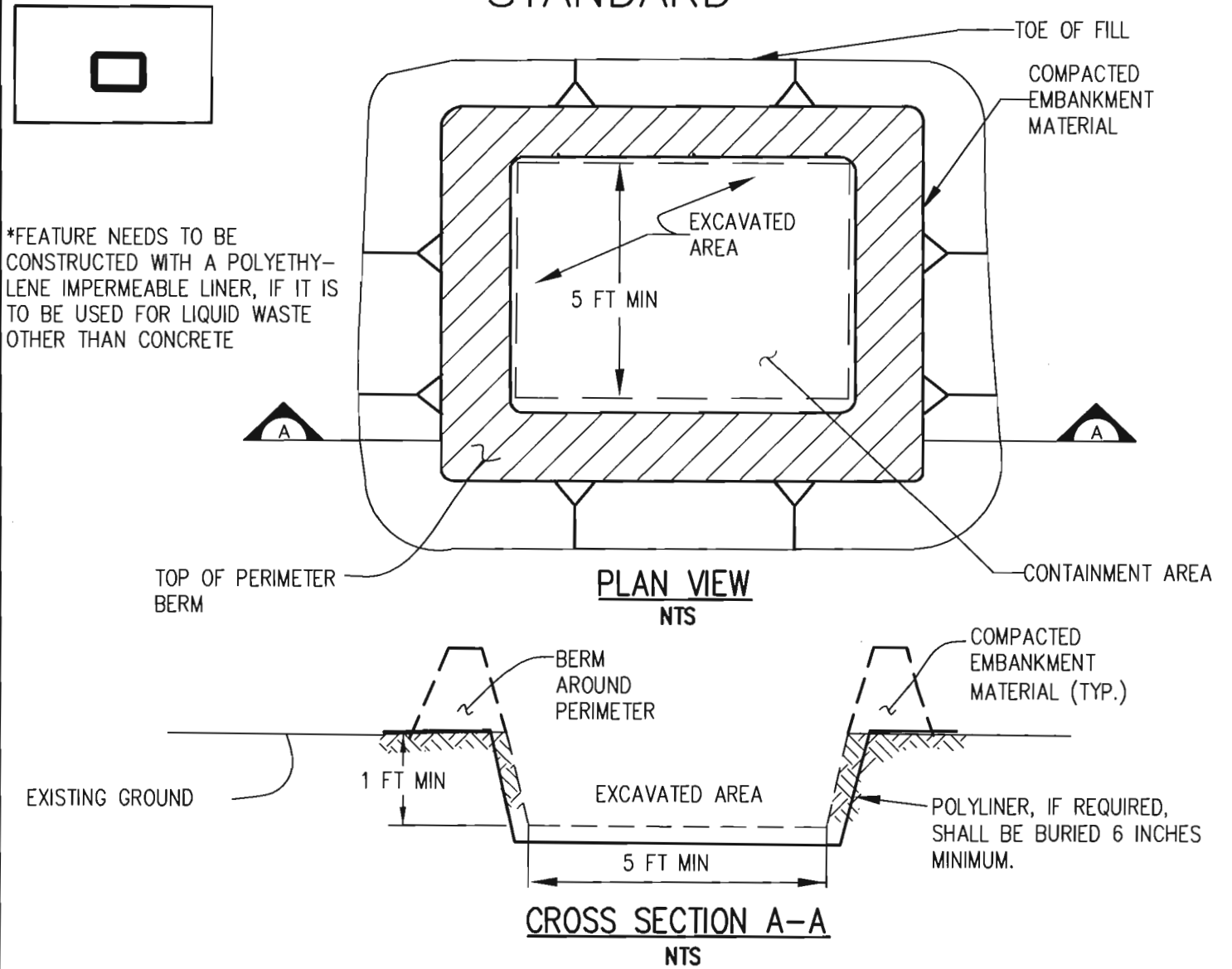

*FEATURE NEEDS TO BE CONSTRUCTED WITH A POLYETHYLENE IMPERMEABLE LINER, IF IT IS TO BE USED FOR LIQUID WASTE OTHER THAN CONCRETE

1. THE CONCRETE WASHOUT AREA SHALL BE INSTALLED PRIOR TO ANY CONCRETE PLACEMENT ON THIS PROJECT.
2. PLASTIC LINING MAY BE REQ'D BASED ON SOIL CONDITIONS, AND IF IT WILL BE USED FOR LIQUID WASTE OTHER THAN CONCRETE.
3. SIGNS SHALL BE PLACED AT THE CONSTRUCTION ENTRANCE, AT THE WASHOUT AREA, AND ELSEWHERE AS NECESSARY TO CLEARLY INDICATE THE LOCATION OF THE CONCRETE WASHOUT AREA TO OPERATORS OF CONCRETE TRUCKS AND OTHER CONTRACTORS.
4. EXCAVATED MATERIAL, SHALL BE UTILIZED IN PERIMETER BERM CONSTRUCTION.
5. THE CONCRETE WASHOUT AREA WILL BE REPAIRED, ENLARGED OR CLEANED OUT AS NECESSARY TO MAINTAIN CAPACITY FOR WASTE CONCRETE AND OTHER LIQUID WASTES.
6. AT THE END OF CONSTRUCTION ALL CONCRETE SHALL BE REMOVED FROM THE SITE IN A WATERTIGHT CONTAINER AND DISPOSED OF AT AN APPROVED WASTE SITE.
7. WHEN THE CONCRETE WASHOUT AREA IS REMOVED. THE DISTURBED AREA SHALL BE DRILL SEEDED AND CRIMP MULCHED OR OTHERWISE STABILIZED IN A MANNER APPROVED BY CITY.
8. ALTERNATIVES FOR SMALL SITES MAY INCLUDE PLASTIC KIDDIE POOLS OR WATERTIGHT MANUFACTURED BINS. IMPLEMENT WITH A REDUNDANT BMP.
9. AT NO TIME SHALL LIQUID WASTES BE PUMPED OUT ONTO DISTURBED GROUND WITHOUT BEING CONTAINED OR, OUT OF THE WASHOUT AREA AND INTO THE STREET AND/OR STORM SEWER.
10. CONDITIONS MAY WARRANT THE USE OF POLYETHYLENE LINER, AS DIRECTED BY THE CITY.

CITY OF AURORA, COLORADO <i>Chris J. Stettin</i> 7/1/10 AURORA WATER DEPARTMENT DATE <i>Kerim Wegener</i> 9-2-10 CITY ENGINEER DATE	SMALL SITE CONCRETE/ LIQUID WASTE WASHOUT	3 OF 4 <div style="border: 1px solid black; border-radius: 50%; width: 60px; height: 60px; margin: 0 auto; display: flex; align-items: center; justify-content: center;"> CWS </div>
---	---	---

STANDARD

Small Liquid Waste Washout – is a feature installed for incidental washouts from cleaning tools, buckets and/or equipment. The discharge or disposal of any water contaminated by waste products from; painting, sheet rock installation, grouting, masonry, cleaning, cutting or other operations that include the use of potential pollutant source products directly onto the ground, to inlets, curb flow lines, adjacent waterways, wetlands, other properties, etc., is prohibited. The Permittee(s), and/or their authorized agents shall protect all drainageways, flow lines, adjacent waterways, wetlands, other properties, etc., adjacent to any location where pavement cutting operations involving wheel cutting, saw cutting or abrasive water jet cutting are to take place. The Permittee shall remove and properly dispose of all waste products generated by painting, sheet rock installation, grouting, masonry, cleaning, cutting and similar operations that include the use of potential pollutant source products.



Small washout facilities used for liquid waste from painting, sheet rock installation, grouting, masonry, and etc. operations must be constructed with a polyethylene impermeable liner.



Features need to be installed and maintained in good operating condition to avoid failures.

CITY OF AURORA, COLORADO

Chris Soto 11/2/10
AURORA WATER DEPARTMENT DATE

Kevin Wegener 1.14.10
CITY ENGINEER DATE

SMALL SITE
CONCRETE/ LIQUID WASTE
WASHOUT

4 OF 4



STANDARD

Diversion Channels – are installed as temporary stream or other watercourse diversions and are used for diverting the base flows of perennial streams around construction activities by using a conduit (pipe) or small diversion ditch. Its function is to maintain stream flow continuity, quality, provide a dry working environment for the construction activities, and/or allow the installation of a structure in a perennial stream with minimal impacts on stream turbidity. By temporarily diverting the stream's base flow away from the construction area and into a stable pipe or channel system; clean water is kept out of the active construction area. This practice applies where flows are low enough and/or the watershed is small enough to allow normal base flows to be handled practically in a conduit (pipe) or small diversion ditch. It is intended for situations where the temporary stream diversion will ideally only be needed during the months of low stream flow, where the time of construction can be minimized, and the site can be effectively stabilized post-construction. More permanent engineered structures will be needed for projects involving large streams or rivers that are expected to be under construction for extended periods.

Any work within a stream is subject to the oversight, jurisdiction and rules and regulations of the U.S. Army Corps of Engineers for in-stream modifications (404 permit), and The CDPHE Water Quality Control Division.

Key Installation and Maintenance Requirements:

- Timing the installation of this feature is critical to minimize potential impacts on aquatic life and spawning areas
- To minimize the impact to the stream, phasing the operations must be considered before the stream is diverted
- This measure needs to be quickly and carefully installed, well maintained and removed as soon as possible when the construction area is stable
- Care needs to be executed so that these features do not increase the velocity of flow due to constriction of the channel, creating a higher potential for erosion and movement of sediments in the stream channel. Base flows must be maintained at all times
- This practice is a high maintenance item, and its use considered cautiously. The impact of failure on downstream facilities should be carefully considered. In addition, aquatic needs such as fish passage may preclude the use of this practice
- Disturbance within the confines of stream banks are required to be conducted "in the dry" or separate from flowing water. **No excavation equipment should ever be operated in flowing waters.** Equipment used for construction of diversion features should be free of leaks, and should be clean of petroleum residue
- Vegetation should only be disturbed where necessary. Care should be taken not to damage vegetation beyond the limits for constructing a diversion feature
- No earth, sands, silts, clays or organic materials should be used for construction within the waterway
- Diversion channels should be stabilized with fabric, geotextile, or an impervious plastic lining to prevent and control channel erosion and sedimentation in the waterway. Channel linings shall be; keyed in at the top of the channel with compacted soils, properly oriented, and with seams appropriately overlapped to prevent failure
- Erosion control features shall be installed in adjoining areas to control sediment loss into the temporary watercourse.
- Diversion channels should not be constructed within the dripline of existing trees. Damage to or death of trees will require mitigation per City's Tree Preservation Policy.

CITY OF AURORA, COLORADO

Chris Steen 9/1/10
AURORA WATER DEPARTMENT DATE

Kevin Wegener 9-2-10
CITY ENGINEER DATE

DIVERSION CHANNELS

1 OF 6



STANDARD

DIVERSION CHANNEL WITH CROSSING
ACCEPTABLE LININGS
(CROSS SECTION A-A OF 1 OF 4)

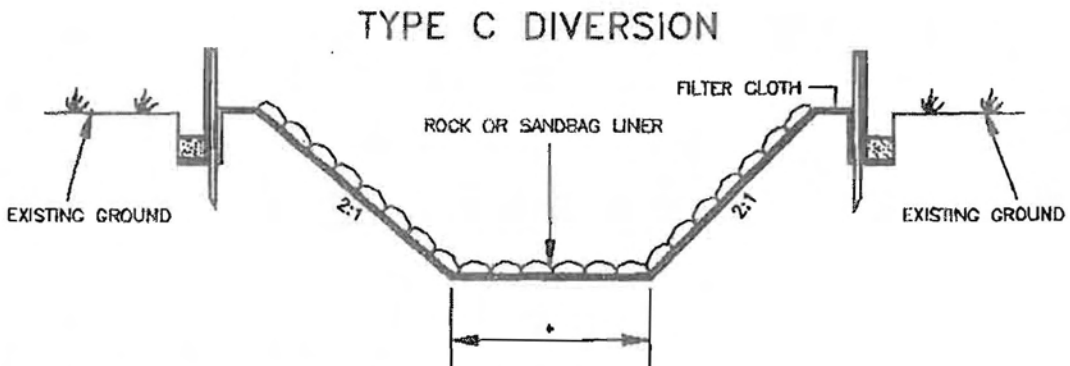
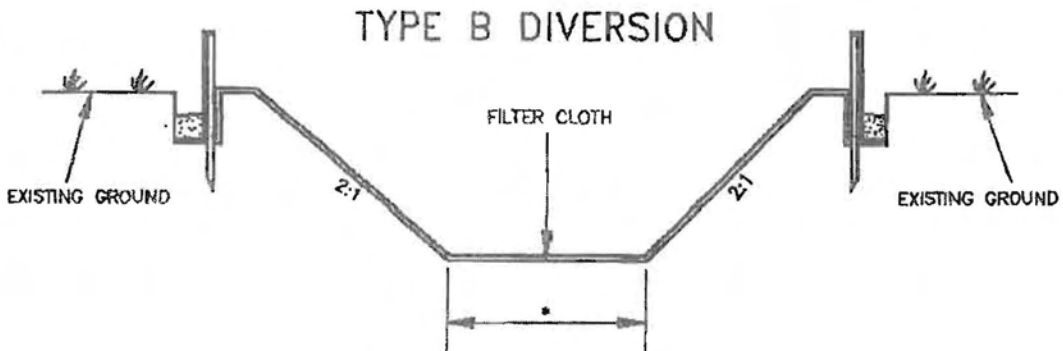
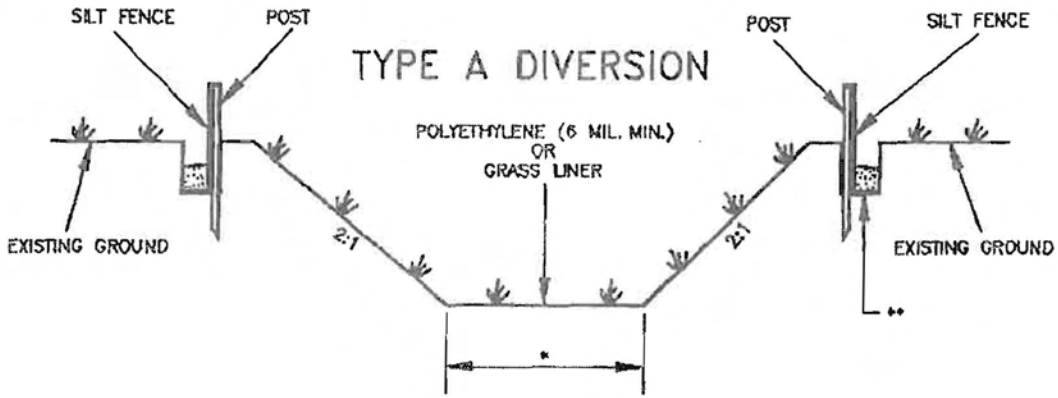

- * 6' MINIMUM OR WIDTH OF EXISTING STREAM WHICHEVER IS LESS
- ** ENTRENCH SILT FENCE AND FILTER CLOTH IN SAME TRENCH

Source: Adapted from VDOT Standard Sheets

CITY OF AURORA, COLORADO

Joseph E. Wray 6-5-09
AURORA WATER DEPARTMENT DATE
Kevin Wegener 6-4-09
CITY ENGINEER DATE

DIVERSION CHANNELS

2 OF 6



STANDARD COFFERDAM DIVERSION

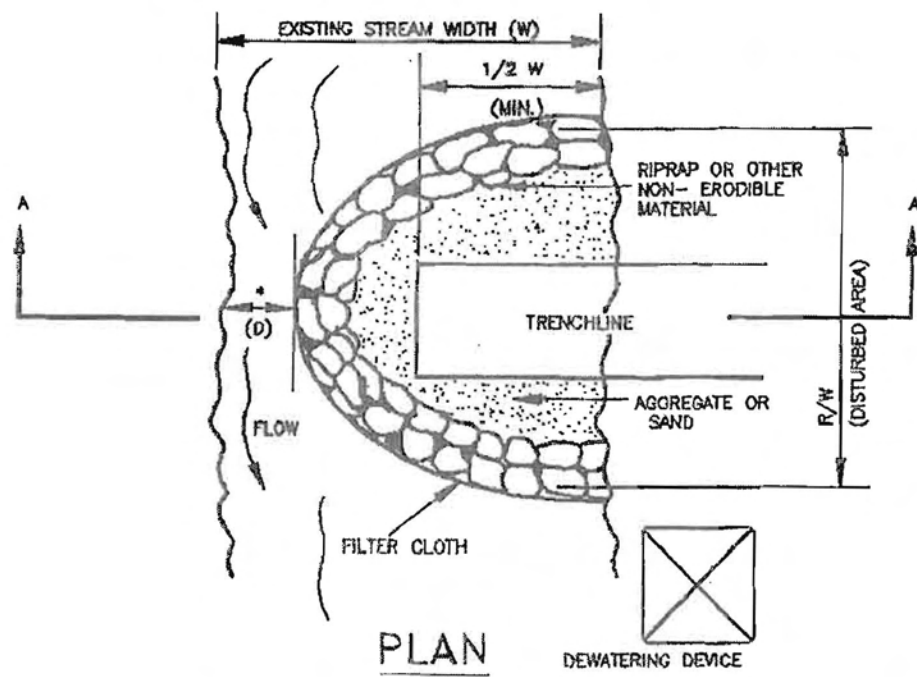

PLAN

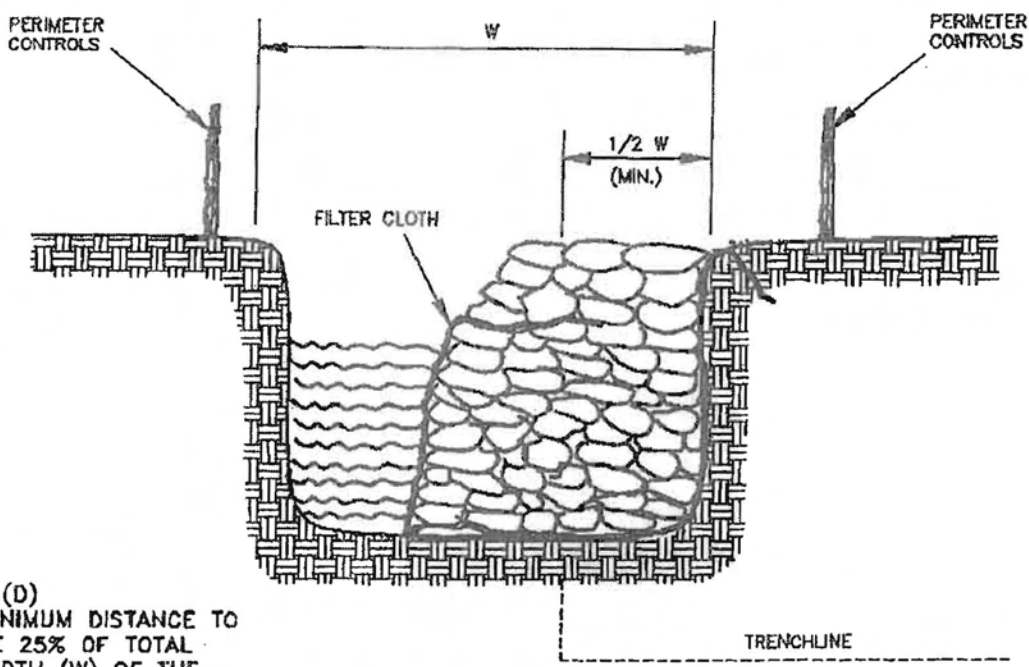

SECTION A-A

* (D)
MINIMUM DISTANCE TO
BE 25% OF TOTAL
WIDTH (W) OF THE
STREAM.

Source: Va. DSWC

CITY OF AURORA, COLORADO <i>Jared S. Weger</i> 6-5-09 AURORA WATER DEPARTMENT DATE
<i>Kevin Weger</i> 6-4-09 CITY ENGINEER DATE

DIVERSION CHANNELS

3 OF 6

DC

STANDARD FLUME PIPE DIVERSION

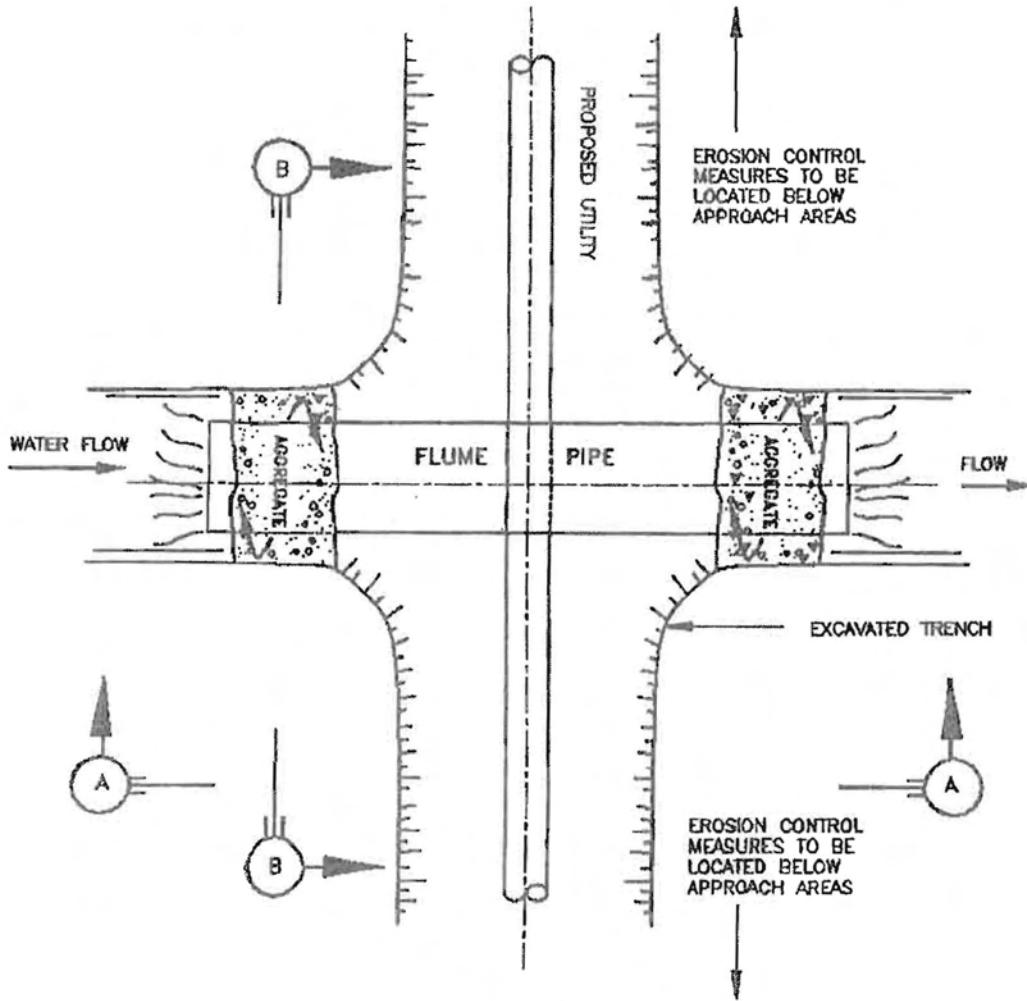

PLAN VIEW

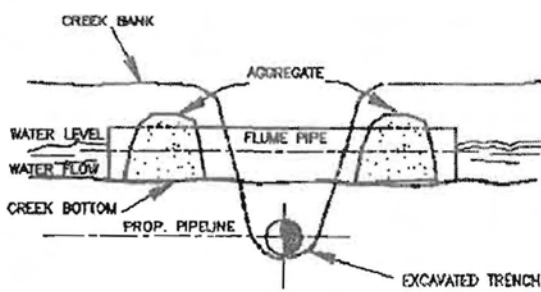

SECTION "A-A"

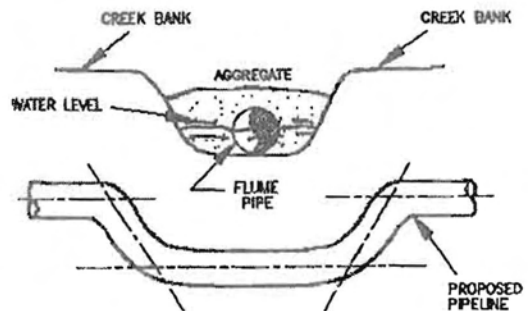

SECTION "B-B"

Source: Va. DSWC

CITY OF AURORA, COLORADO

John J. Waters 6-5-09
AURORA WATER DEPARTMENT DATE

Kevin Wegener 6-4-09
CITY ENGINEER DATE

DIVERSION CHANNELS

4 OF 6



DIVERSION CHANNEL WITH CROSSING

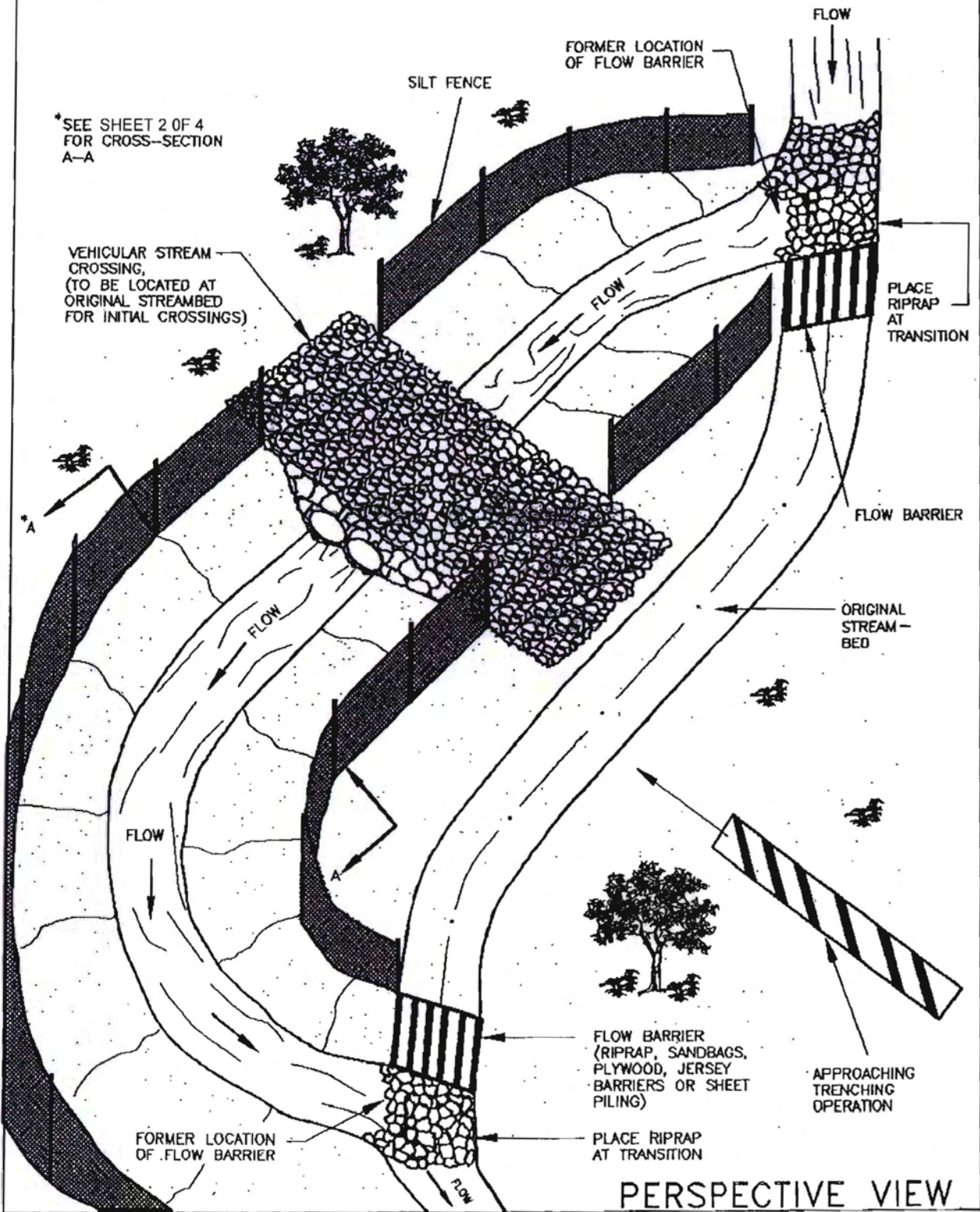

Source: Va. DSWC

CITY OF AURORA, COLORADO

Chris 28th 1/12/10
 AURORA WATER DEPARTMENT DATE

Kevin Wegener 1-14-10
 CITY ENGINEER DATE

DIVERSION CHANNELS

5 OF 6



STANDARD

Lined Channel Diversion



Use of unlined diversions is not allowed. Note the turbidity here from the eroding channel.

CITY OF AURORA, COLORADO

Chris [Signature] 11/12/10
AURORA WATER DEPARTMENT DATE

Kevin Weyener 1-14-10
CITY ENGINEER DATE

DIVERSION CHANNELS

6 OF 6



STANDARD

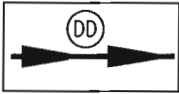

DEFINITION

A TEMPORARY RIDGE OF COMPACTED SOIL LOCATED AT THE TOP, MIDSLOPE, OR BASE OF A DISTURBED AREA.

PURPOSE OF DD

- * TO DIVERT STORM RUNOFF FROM HIGHER DRAINAGE AREAS AWAY FROM UNPROTECTED SLOPES TO A PERMANENT CHANNEL OR TEMPORARY CHANNEL DIVERSION.
- * TO DIVERT SEDIMENT-LADEN RUNOFF FROM THE MIDSLOPE OF A DISTURBED AREA TO A TEMPORARY SLOPE DRAIN.
- * TO DIVERT SEDIMENT-LADEN RUNOFF FROM THE BASE OF A DISTURBED AREA TO A SEDIMENT TRAPPING FACILITY.

PURPOSE OF EB

- * RETAIN SOIL
- * RETAIN SEDIMENT LADEN RUNOFF FROM A VERY SMALL AREA (IE TREE LAWN OR SMALL STOCKPILE OF SOIL OR OTHER MATERIALS)
- * PROVIDE ADDITIONAL PROTECTION AROUND A CONCRETE WASHOUT

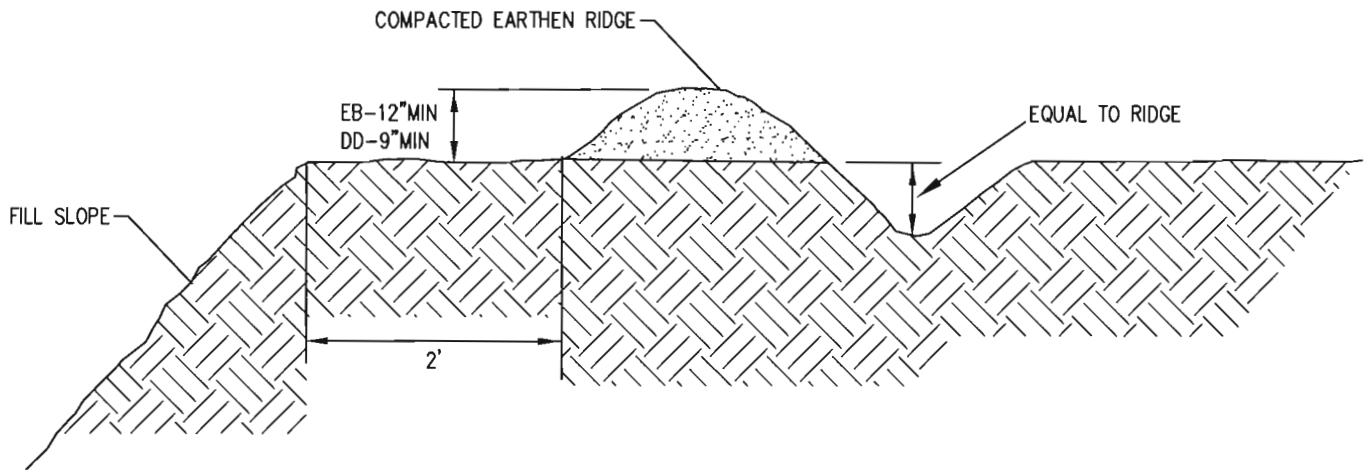

NOTES

1. ENGINEERS SHALL VERIFY GRADES OF THE DIVERSION DITCH AND THE SEDIMENT BASIN/TRAP OR CHANNEL TO ENSURE FLOW.
2. IF SLOPE OF DIVERSION DITCH EXCEEDS 2%, ROCK CHECK DAMS SHALL BE REQUIRED TO BE INSTALLED IN THESE AREAS.
3. SOIL TYPE MAY REQUIRE INSTALLATION OF RIP RAP AT DIVERSION DITCH CONNECTION TO SEDIMENT BASIN/TRAP OR CHANNEL TO AVOID EROSION.
4. A COMPACTED EARTHEN BERM MAY BE INSTALLED WITHOUT THE INTENTION OF DIRECTING FLOW. IT SHOULD BE LABELED AS (EB)

CITY OF AURORA, COLORADO

Clayton 7/1/10
AURORA WATER DEPARTMENT DATE

Kevin Wegener 9-2-10
CITY ENGINEER DATE

TEMPORARY DIVERSION DIKE
DITCH/EARTHEN BERM

1 OF 2



STANDARD

Diversion Ditch and/or Diversion Berm - is a small, temporary earthen channel or compacted berm used to divert and convey runoff, usually to a sediment basin, trap, or pond. Depending on slope and anticipated flows, the diversion ditch may need to be lined temporarily with erosion control blankets, check dams, or other liner.

Key Installation and Maintenance Requirements:

- In locations where construction traffic must cross a diversion ditch, the Permittee(s) should install a temporary culvert with a minimum diameter of 12 inches
- Ditches and berms need to be routinely inspected and monitored for regrooming or other maintenance.



Ditches and berms need to be installed correctly and monitored for function. This feature is experiencing ditch cutting and has loaded the pond with sediment.

CITY OF AURORA, COLORADO

Clayton 1/12/10
AURORA WATER DEPARTMENT DATE

Kevin Wegener 1.14.10
CITY ENGINEER DATE

DIVERSION DITCH/BERM

2 OF 2



STANDARD

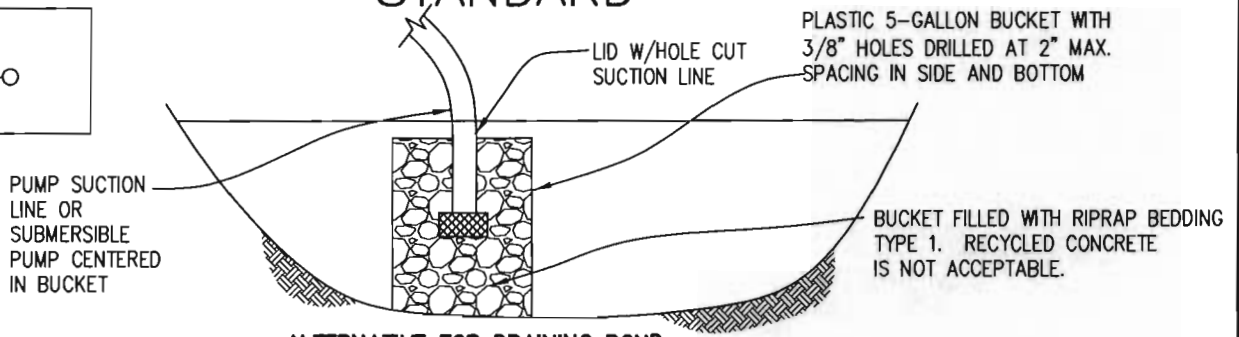
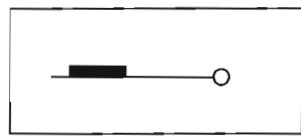

**ALTERNATIVE FOR DRAINING POND
ALREADY FILLED WITH WATER**

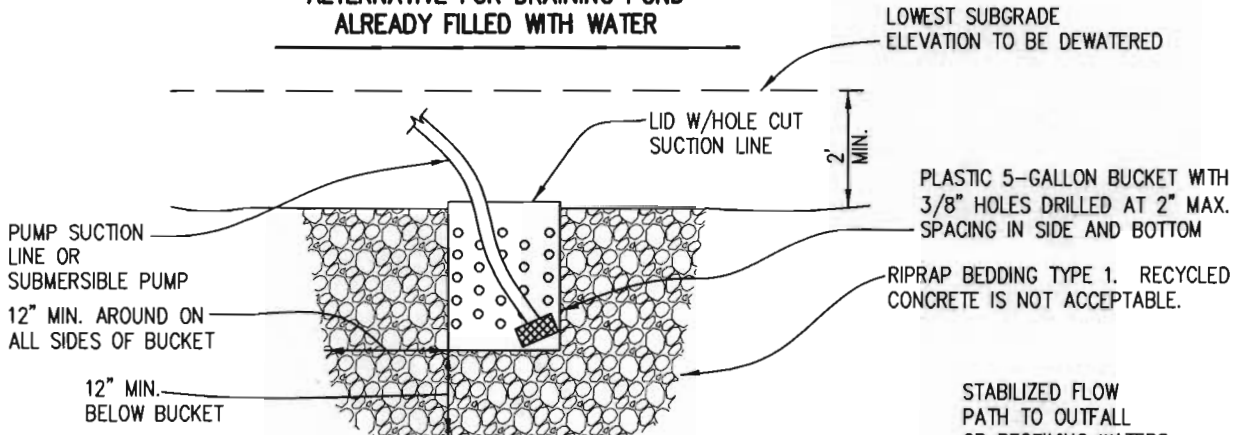

DEWATERING SUMP FOR SUBMERSIBLE PUMP-DETAIL 1

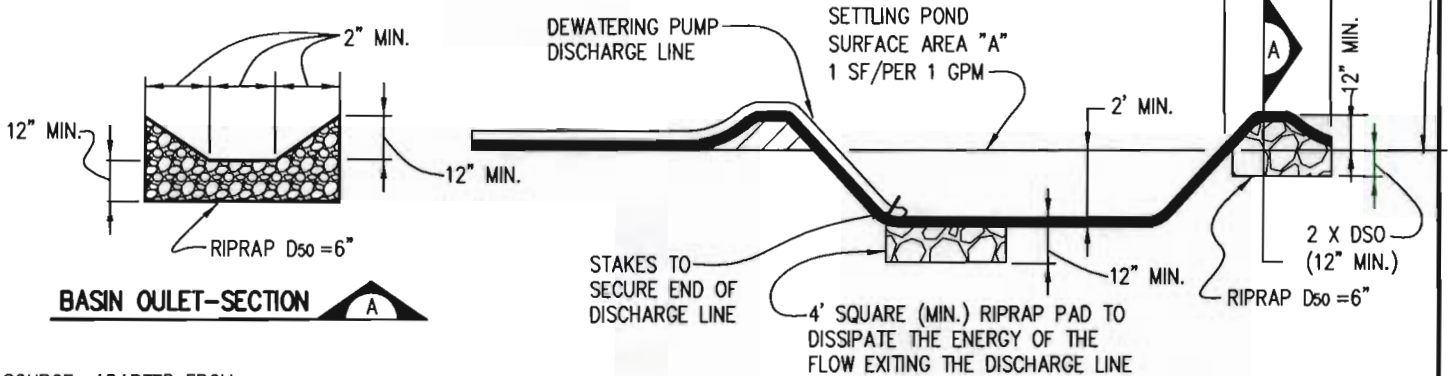

**SUMP DISCHARGE
SETTLING BASIN-DETAIL 2**

SOURCE: ADAPTED FROM
DOUGLAS COUNTY GESC
STANDARD DETAILS

- NOTES:
1. THE OWNER SHALL OBTAIN A CONSTRUCTION DISCHARGE (DEWATERING) PERMIT FROM THE COLORADO DEPARTMENT OF PUBLIC HEALTH AND ENVIRONMENT PRIOR TO ANY DEWATERING OPERATIONS UNLESS ABLE TO COMPLY WITH THE CDPS PERMIT REQUIREMENTS. ALL DEWATERING SHALL BE IN ACCORDANCE WITH THE REQUIREMENTS OF THE DISCHARGE PERMIT AND SHALL BE COORDINATED WITH THE CITY ENVIRONMENTAL INSPECTOR.
 2. THE OPERATOR SHALL PROVIDE, OPERATE, AND MAINTAIN DEWATERING SYSTEMS OF SUFFICIENT SIZE AND CAPACITY TO PERMIT EXCAVATION AND SUBSEQUENT CONSTRUCTION IN DRY CONDITIONS AND TO LOWER AND MAINTAIN THE GROUNDWATER LEVEL A MINIMUM OF 2- FEET BELOW THE LOWEST POINT OF EXCAVATION AND CONTINUOUSLY MAINTAIN EXCAVATIONS FREE OF WATER UNTIL BACKFILLED TO FINAL GRADE.
 3. DEWATERING OPERATIONS SHALL USE ONE OR MORE OF THE DEWATERING SUMPS SHOWN ABOVE OR OTHER MEANS APPROVED BY THE CITY TO REDUCE THE PUMPING OF SEDIMENT, AND SHALL PROVIDE A TEMPORARY BASIN FOR SETTLING PUMPED DISCHARGES PRIOR TO RELEASE OFF SITE OR TO A RECEIVING WATER. A SEDIMENT BASIN MAY BE USED IN LIEU OF SUMP DISCHARGE SETTLING BASIN SHOWN ABOVE.
 4. A 4' SQUARE RIPRAP PAD SHALL BE PLACED AT DISCHARGE POINT.
 5. THE DISCHARGE END OF THE LINE SHALL BE STAKED IN PLACES TO PREVENT MOVEMENT OF RIPRAP PAD.
 6. SILT SACKS FLTR BOXES, AND/OR PORTABLE SEDIMENT TANKS MAY BE USED IN PLACE OF A SETTLING BASIN.
 7. DO NOT EXCAVATE WITHIN DRIPLINE OF EXISTING TREES.

CITY OF AURORA, COLORADO

Ching 2 gtr 9/1/10
AURORA WATER DEPARTMENT DATE
Kevin Wegener 9.2.10
CITY ENGINEER DATE

DEWATERING

1 OF 4



STANDARD

FILTER BOX

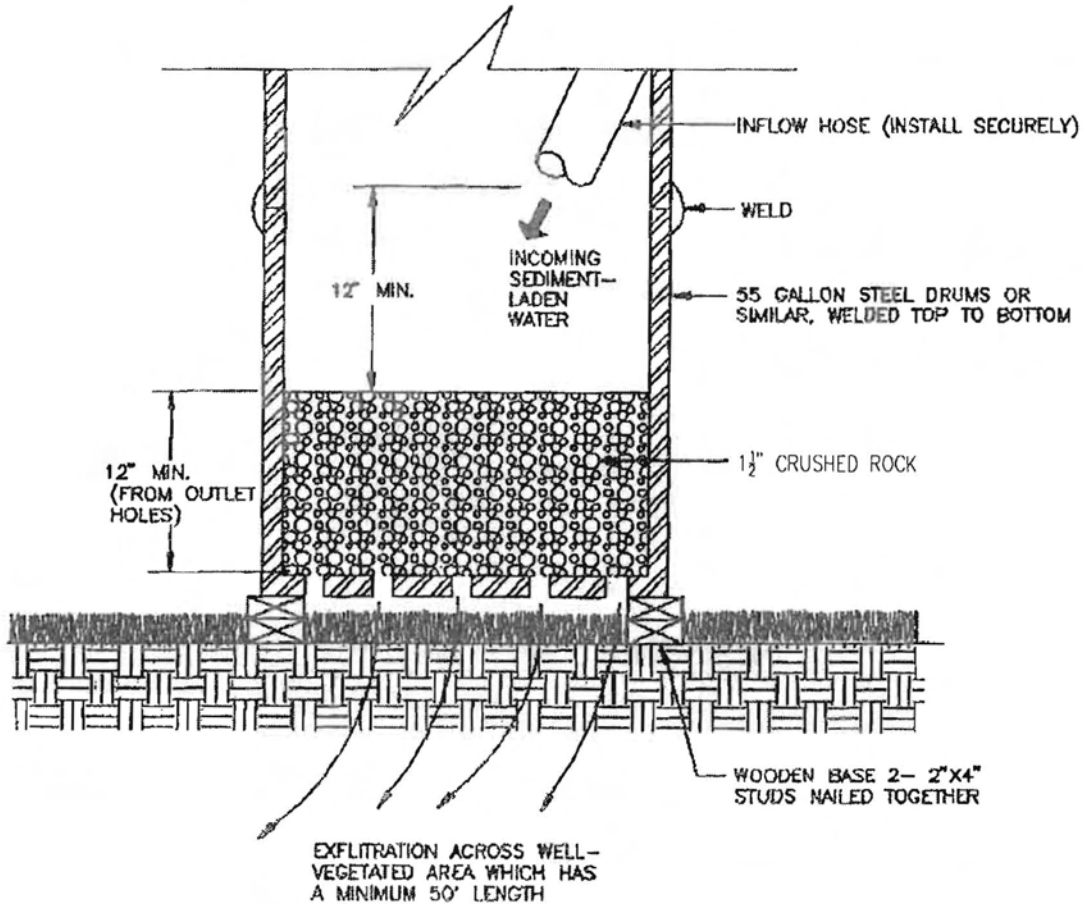

ELEVATION VIEW

Source: Va. DSWC

CITY OF AURORA, COLORADO

Joseph S. W. [Signature] 6-9-09
AURORA WATER DEPARTMENT

DATE

Kevin Wegener [Signature] 6-4-09
CITY ENGINEER

DATE

DEWATERING
FILTER BOX

2 OF 4



STANDARD

PORTABLE SEDIMENT TANK

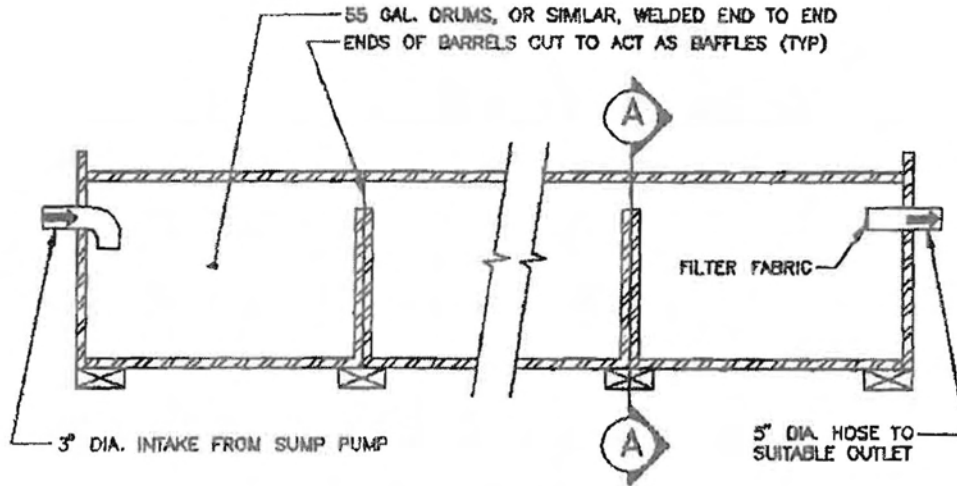

ELEVATION

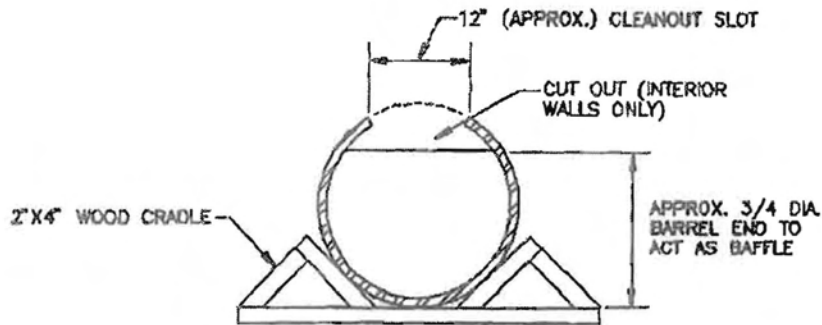

CROSS-SECTION A-A

Source: USDA-SCS

CITY OF AURORA, COLORADO

AURORA WATER DEPARTMENT

CITY ENGINEER

Joseph E. W... 6-5-09
DATE

Kevin W... 6-4-09
DATE

DEWATERING
PORTABLE SEDIMENT TANK

3 OF 4



STANDARD

Dewatering Operations. COA Inspectors will monitor all dewatering activities for any potential concerns with sediment or pollutant-laden discharges impacting stormdrains, waterways, wetlands, etc. and the adherence to the CDPHE *Construction Dewatering Wastewater Discharge* permitting conditions, other permits or water quality standards. Appropriate controls need to be implemented so discharges will fall within the permitted perimeters. The measures depicted within this standard may not be sufficient to ensure permit compliance, depending on the volume of water, quality of water at the pumping site, soils, storm events or other conditions.



Dewatering operation with multiple well points.

Discharge area established with filtration bags.



Discharging sediment-laden water to a stormdrain is a Permit violation.

CITY OF AURORA, COLORADO

Chris 28th 1/12/10
AURORA WATER DEPARTMENT DATE

Kevin Wegener 1.14.10
CITY ENGINEER DATE

DEWATERING

4 OF 4



STANDARD

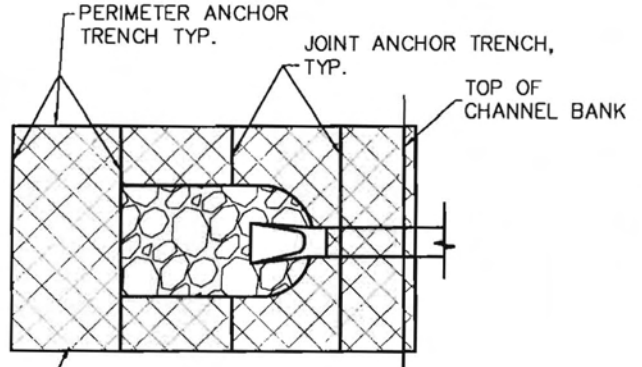

TYPE OF BLANKET AS INDICATED IN PLAN VIEW, IN ALL DISTURBED AREAS OF STREAMS AND DRAINAGE CHANNELS TO DEPTH "D" ABOVE CHANNEL INVERT. BLANKET SHALL GENERALLY BE ORIENTED PARALLEL TO FLOW DIRECTION. STAKING PATTERN SHALL MATCH BLANKET TYPE.

IN DISTURBED AREAS OF
STREAMS AND DRAINAGE CHANNELS

PER MANUFACTURER SPEC. OR TYPE 2 OR 3 STAKING (MATCH SPECIFIED BLANKET TYPE) SEE THE STAKING PATTERNS DETAILS ON SHEET 2.

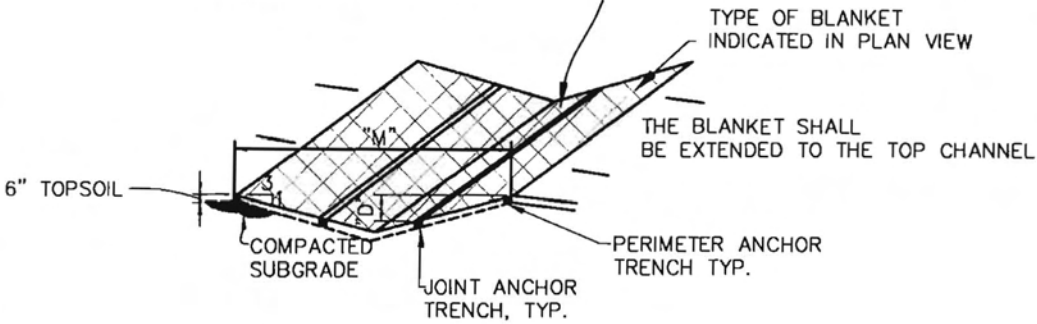

IN DIVERSION DITCH OR
SMALL DITCH DRAINAGEWAY

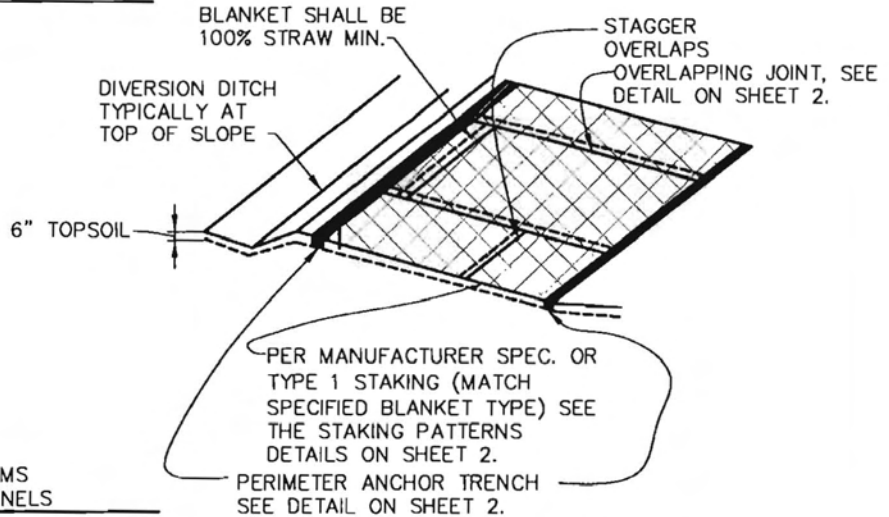

SOURCE: ADAPTED FROM
DOUGLAS COUNTY GESC
STANDARD DETAILS

OUTSIDE OF STREAMS
AND DRAINAGE CHANNELS

CITY OF AURORA, COLORADO
Joseph S. Weger 6-5-09
AURORA WATER DEPARTMENT DATE
Joseph S. Weger 6-4-09
CITY ENGINEER DATE

EROSION CONTROL
BLANKET

1 OF 4
ECB

STANDARD

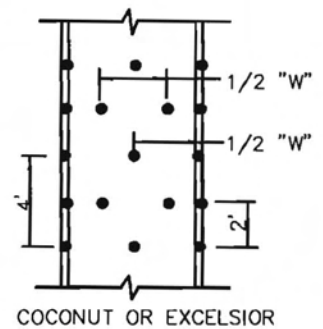
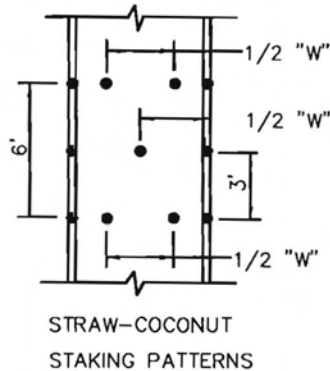
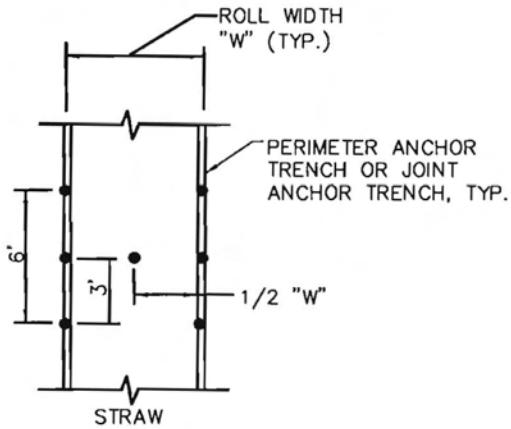
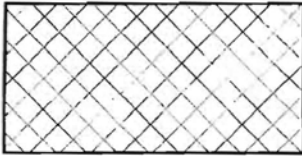

SHALL BE IN ACCORDANCE WITH MANUFACTURER'S SPECIFICATION. IF NO MANUFACTURER'S SPECIFICATION IS AVAILABLE USE THE ACCEPTABLE STAKING PATTERN (AS SHOWN ABOVE).

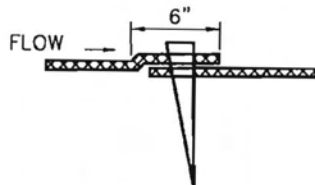

OVERLAPPING JOINT

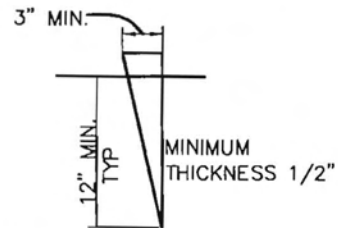

WOOD STAKE DETAIL

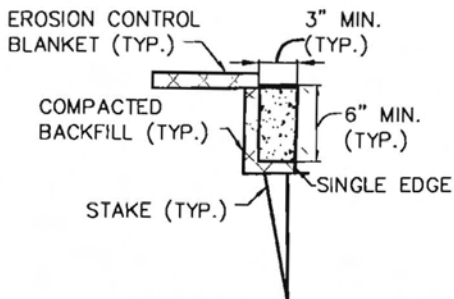

PERIMETER ANCHOR TRENCH

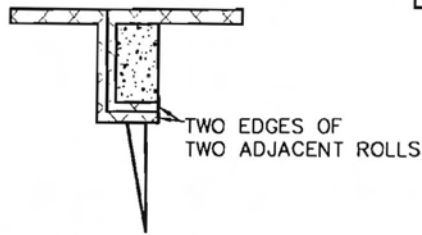

JOINT ANCHOR TRENCH

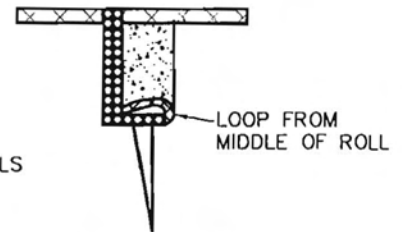

INTERMEDIATE ANCHOR TRENCH

SOURCE: ADAPTED FROM DOUGLAS COUNTY GESC STANDARD DETAILS

CITY OF AURORA, COLORADO

Joseph J. Wray 6-5-09
 AURORA WATER DEPARTMENT DATE
Kevin Wegener 6-4-09
 CITY ENGINEER DATE

EROSION CONTROL
BLANKET

2 OF 4



STANDARD

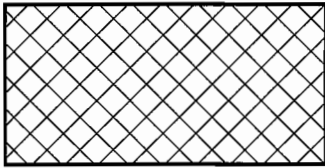

NOTES:

1. SEE PLAN VIEW FOR:
 -LOCATION OF PERIMETER OF EROSION CONTROL BLANKET.
 -TYPE OF BLANKET (STRAW, STRAW-COCONUT, COCONUT, OR EXCELSIOR).
2. ALL EROSION CONTROL BLANKETS AND NETTING SHALL BE MADE OF 100% NATURAL AND BIODEGRADABLE MATERIAL; NO PLASTIC OR OTHER SYNTHETIC MATERIAL, EVEN IF PHOTO DEGRADABLE, SHALL BE ALLOWED.
3. IN AREAS WHERE EROSION CONTROL BLANKET IS SHOWN ON THE PLANS, THE PERMITTEE SHALL PLACE TOPSOIL AND PERFORM FINAL GRADING, SURFACE PREPARATION, AND SEEDING BELOW THE BLANKET. SUBGRADE SHALL BE SMOOTH AND MOIST PRIOR TO BLANKET INSTALLATION AND THE BLANKET SHALL BE IN FULL CONTACT WITH SUBGRADE, NO GAPS OR VOIDS SHALL EXIST UNDER THE BLANKET.
4. PERIMETER ANCHOR TRENCH SHALL BE USED AT OUTSIDE PERIMETER OF ALL BLANKET AREAS.
5. JOINT ANCHOR TRENCH SHALL BE USED TO JOIN ROLLS OF BLANKETS TOGETHER (LONGITUDINALLY AND TRANSVERSELY) FOR ALL BLANKETS EXCEPT STRAW, WHICH MAY USE AN OVERLAPPING JOINT.
6. INTERMEDIATE ANCHOR TRENCH SHALL BE USED AT SPACING OF ONE-HALF THE ROLL LENGTH FOR COCONUT AND EXCELSIOR BLANKETS.
7. THE OVERLAPPING JOINT DETAIL SHALL BE USED TO JOIN ROLLS OF BLANKETS TOGETHER FOR BLANKETS ON SLOPES.
8. MATERIAL SPECIFICATIONS OF EROSION CONTROL BLANKET SHALL CONFORM TO THE TABLE.
9. EROSION CONTROL BLANKET IS TO BE LEFT IN PLACE UNLESS REQUESTED TO BE REMOVED BY THE CITY.
10. ANY EROSION CONTROL BLANKET PULLED OUT, TORN, OR OTHERWISE DAMAGED SHALL BE REINSTALLED. ANY SUBGRADE AREAS BELOW THE BLANKET THAT HAVE ERODED TO CREATE A VOID UNDER THE BLANKET, OR THAT REMAIN DEVOID OF GRASS SHALL BE REPAIRED, RESEEDED AND THE EROSION CONTROL BLANKET REINSTALLED.
11. PERMANENT STAKING OPTIONS MAY INCLUDE BIODEGRADABLE OR WOOD STAKES.
12. TEMPORARY (LESS THAN OR EQUAL TO 1 YEAR) STAKING OPTIONS MAY INCLUDE BIODEGRADABLE OR WOOD STAKES OR METAL PINS.

EROSION CONTROL BLANKET TYPE

TYPE	COCONUT CONTENT	STRAW CONTENT	EXCELSIOR CONTENT	NETTING MIN.
STRAW*	-	100%	-	DOUBLE/NATURAL
STRAW-COCONUT	30% MIN.	70% MAX	-	DOUBLE/NATURAL
COCONUT	100%	-	-	DOUBLE/NATURAL
EXCELSIOR	-	-	100%	DOUBLE/NATURAL

*FOR OUTSIDE OF STREAMS AND DRAINAGE CHANNELS

SOURCE: ADAPTED FROM
DOUGLAS COUNTY GESC
STANDARD DETAILS

CITY OF AURORA, COLORADO AURORA WATER DEPARTMENT CITY ENGINEER	11/5/10 DATE 11-9-10 DATE	EROSION CONTROL BLANKET	3 OF 4
--	------------------------------------	----------------------------	------------

STANDARD

Erosion Control Blanket(s) - are installed to help stabilize disturbed areas by establishing temporary cover and protection to seed beds and promote vegetative growth while reducing both wind and water erosion.

Key Installation and Maintenance Requirements:

- The subgrade should be smooth and moist prior to blanket installation and the blanket should be in full contact with the subgrade; no gaps or voids should exist under the blanket
- An anchor trench should be used at the upgradient edge of all installations
- Blankets should be oriented correctly, with seams overlapped at least 6-inches and secured with wood stakes, or other biodegradable means
- Features need to be maintained in place until significant vegetative cover has been uniformly established.



Installed features need to be routinely inspected to evaluate on-going function and integrity. Maintenance and repairs should be immediately initiated when function of the installation has been impaired.

CITY OF AURORA, COLORADO

Chris [Signature] 1/12/10
AURORA WATER DEPARTMENT DATE
Kevin Wejner 1.14.10
CITY ENGINEER DATE

EROSION CONTROL
BLANKET

4 OF 4



STANDARD

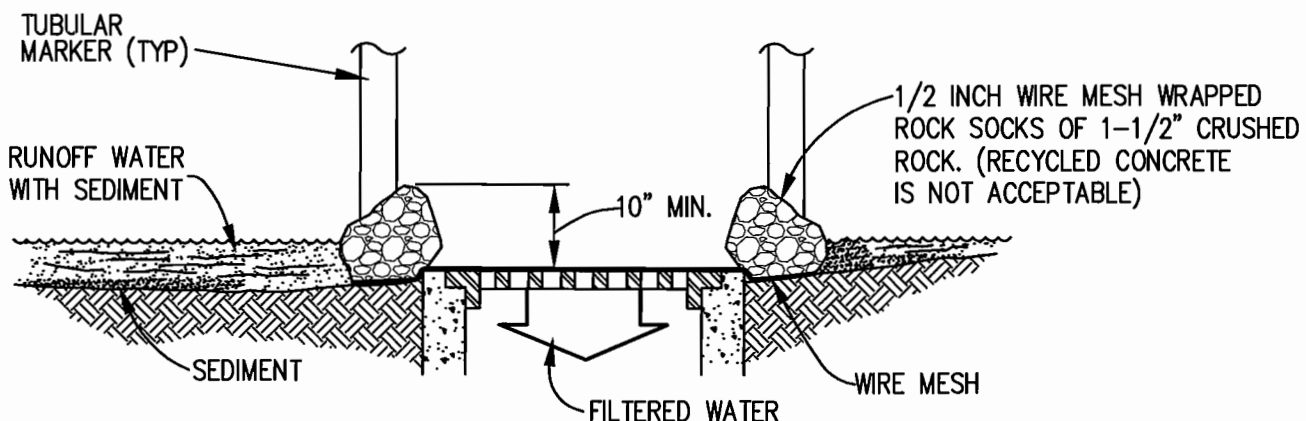
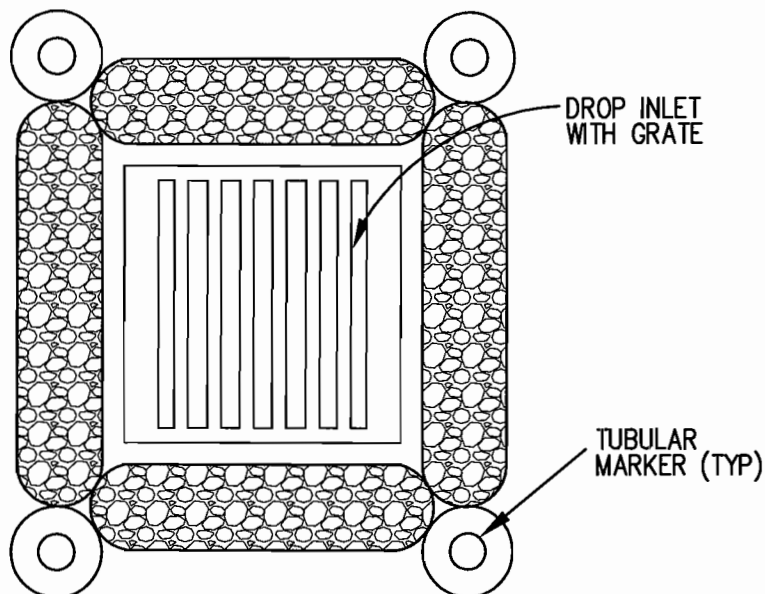
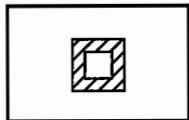

INLET PROTECTION INSTALLATION NOTES

1. INLET PROTECTION AT AREA INLETS SHALL BE INSTALLED WITHIN 72-HOURS OF POURING INLET.
2. CRUSHED ROCK SHALL BE FRACTURED FACE (ALL SIDES) AND SHALL BE 1-1/2".
3. WIRE MESH SHALL BE FABRICATED OF MINIMUM 16-20 GAUGE WIRE TWISTED INTO A MESH WITH A MAXIMUM OPENING OF 1/2 INCH. ROLL WIDTH SHALL BE 48-INCHES. 16-20 GAUGE CHICKEN WIRE MAYBE USED IF DOUBLE WRAPPED WITH NO MORE THAN 1/2" OPENINGS.
4. WIRE MESH SHALL BE SECURED USING "HOG RINGS" OR WIRE TIES AT 6-INCH CENTER ALONG ALL JOINTS AND AT 2-INCH CENTERS ON ENDS OF SOCK.
5. SEDIMENT ACCUMULATED UPSTREAM OF INLET PROTECTION SHALL BE REMOVED WHEN THE SEDIMENT DEPTH UPSTREAM OF ROCK SOCKS IS WITHIN 5 INCHES OF THE CREST.
6. CONCRETE BLOCKS AND 2x4 SUPPORTS SHALL BE USED WHEN THERE IS MORE THAN ONE (1) ACRE OF TRIBUTARY DRAINAGE AREA TO THE INLET OR AT ANY TIME ADDITIONAL SUPPORT IS NEEDED TO KEEP ROCK SOCKS IN PLACE.
7. REFER TO (RS) DETAIL FOR MORE INFORMATION.

CITY OF AURORA, COLORADO

Chris J. Smith 11/9/10
 AURORA WATER DEPARTMENT DATE

Kevin Wegener 11.9.10
 CITY ENGINEER DATE

DROP / AREA
 INLET PROTECTION

1 OF 3



STANDARD

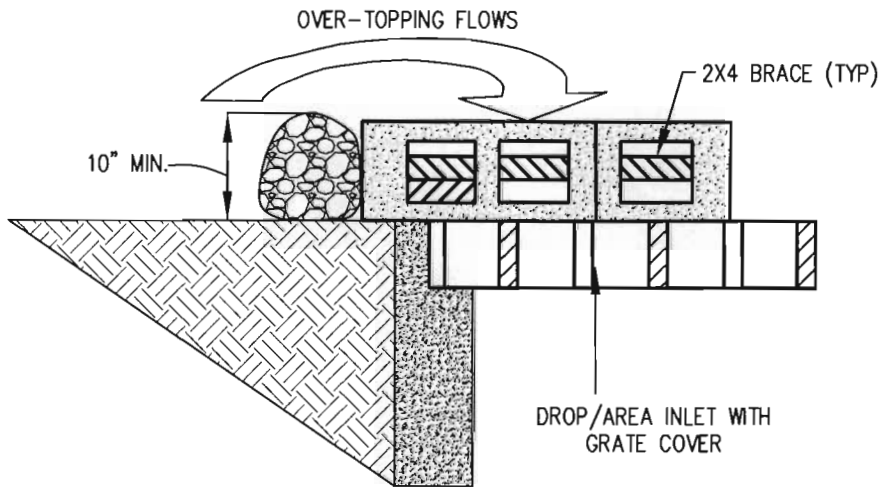
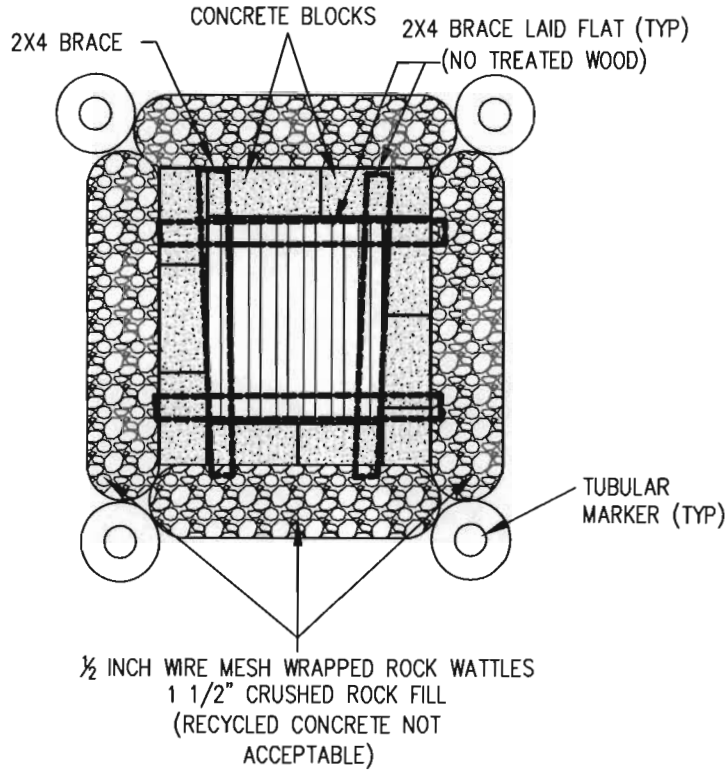
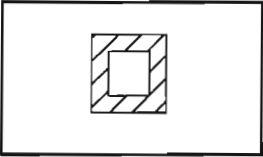

CITY OF AURORA, COLORADO

Chris 25th 9/1/10
AURORA WATER DEPARTMENT DATE

Kevin Wegener 9.2.10
CITY ENGINEER DATE

DROP / AREA
INLET PROTECTION

2 OF 3



STANDARD

Drop/Area Inlet Protection – is established to provide a sediment barrier and control the discharge of sediment-laden waters into the storm drain from any adjoining areas that may not have established vegetative cover

Key Installation and Maintenance Requirements:

- Inlet protection at area inlets should be installed within 72-hours of pouring/placing inlet
- Rock wattles should be constructed in one piece or should be installed using significant overlapping
- Inlet protection is to remain in place until upgradient site activities are completed and disturbed areas are stabilized and vegetative cover is uniformly distributed and established.
- Straw bales and silt fencing are not appropriate applications for providing inlet protection



Inlets without adequate and appropriate control features installed and maintained can easily be overwhelmed with sediment and/or other debris.

CITY OF AURORA, COLORADO
Cling 2/2/10 1/12/10
AURORA WATER DEPARTMENT DATE
Kevin Wegener 1-14-10
CITY ENGINEER DATE

DROP / AREA
INLET PROTECTION

3 OF 3



STANDARD

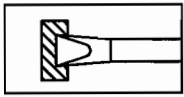

BACKFILL UPSTREAM OF
ROCK SOCKS

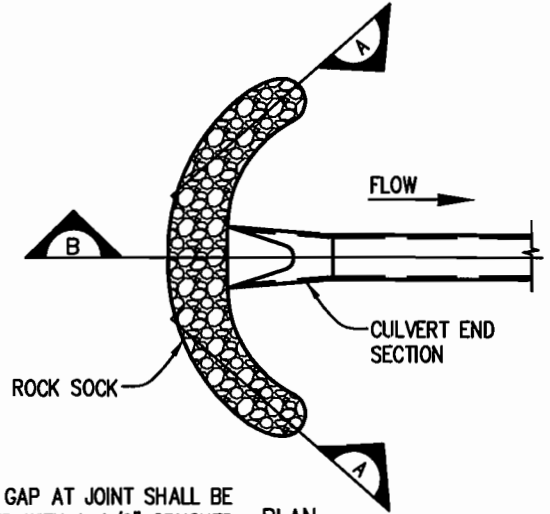
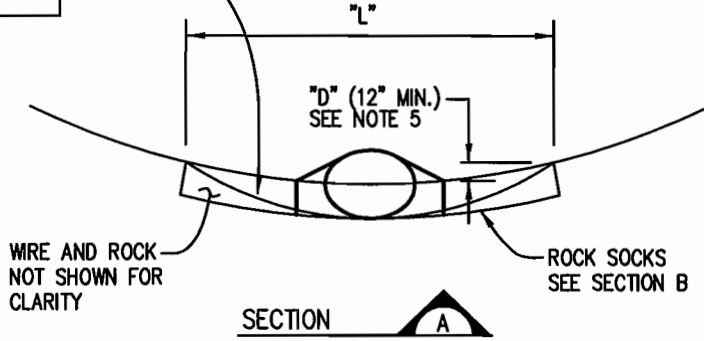

ANY GAP AT JOINT SHALL BE
FILLED WITH 1-1/2" CRUSHED
ROCK AND WRAPPED WITH
ADDITIONAL, 1/2 INCH WIRE MESH
SECURED TO ENDS OF ROCK
SOCKS.

PLAN

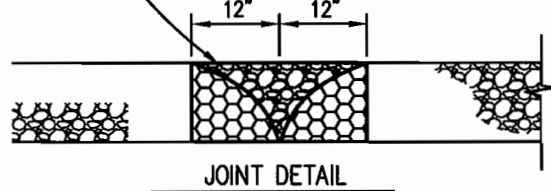

JOINT DETAIL

10" MIN. OR
2-6" ROCK
SOCKS STACKED
VERTICALLY

1-1/2" CRUSHED ROCK
ENCLOSED IN 1/2 INCH WIRE MESH

FLOW

0" ON BEDROCK OR RIPRAP
2" IN EARTH

SECTION B

NOTES:

1. SEE PLAN VIEW FOR:
- LOCATIONS OF CULVERT INLET FILTERS.
2. CRUSHED ROCK SHALL BE FRACTURED FACE (ALL SIDES) AND SHALL COMPLY WITH GRADATION TABLE 1 (1-1/2" MINUS). RECYCLED CONCRETE IS NOT ACCEPTABLE.
3. WIRE MESH SHALL BE FABRICATED OF MINIMUM 16-20 GAUGE WIRE TWISTED INTO A MESH A MAXIMUM OPENING OF 1/2 INCH. 16-20 GAUGE CHICKEN WIRE MAY BE USED IF DOUBLE WRAPPED WITH NO MORE THAN 1/2" OPENINGS.
4. WIRE MESH SHALL BE SECURED USING "HOG RINGS" OR WIRE TIES AT 6-INCH CENTERS ALONG ALL JOINTS AND AT 2-INCH CENTERS ON ENDS OF ROCK SOCKS.
5. THE ENDS OF THE REINFORCED ROCK SOCK SHALL BE 12" HIGHER THAN THE CENTER OF THE ROCK SOCKS.
6. SEDIMENT ACCUMULATED UPSTREAM OF CULVERT INLET FILTER SHALL BE REMOVED WHEN THE SEDIMENT DEPTH UPSTREAM OF FILTER IS 1/2 THE HEIGHT OF THE ROCK SOCK.
7. CULVERT PROTECTION IS TO REMAIN IN PLACE UNTIL THE UPSTREAM DISTURBED AREA IS STABILIZED AND VEGETATIVE COVER IS APPROVED BY THE CITY.
8. AN ADDITIONAL BMP MAY BE REQUIRED ABOVE THE CULVERT OPENING TO MINIMIZE SEDIMENT LADEN WATER BYPASS FROM THE SLOPE.
9. SEE (RS) DETAIL FOR MORE INFORMATION.

SOURCE: ADAPTED FROM
DOUGLAS COUNTY GESC
STANDARD DETAILS

GRADATION TABLE

SIEVE SIZE	MASS PERCENT PASSING SQUARE MESH SIEVES
	NO. 4
2"	100
1 1/2"	90 - 100
1"	20 - 55
3/4"	0 - 15
3/8"	0 - 5
MATCHES SPECIFICATIONS FOR NO. 4 COARSE AGGREGATE FOR CONCRETE PER AASHTO M43. ALL ROCK SHALL BE FRACTURED FACE, ALL SIDES.	

CITY OF AURORA, COLORADO

Clay 2 Str 11/5/10
AURORA WATER DEPARTMENT DATE

Kevin W. Jensen 11.9.10
CITY ENGINEER DATE

CULVERT INLET PROTECTION

1 OF 2



STANDARD

Culvert Inlet Protection – is installed to control sediment (and other) discharges into culvert piping.

Key Installation and Maintenance Requirements:

- Features are intended to be temporary and require removal, when work is completed
- Damaged or broken mesh requires repairs to maintain integrity of the feature(s)
- Straw bales, wattles and silt fencing are not appropriate installations and are not allowed.



Culvert piping without adequate protection can easily take on sediment loading and additional maintenance requirements. Note the lack of stabilization around the tops of the examples on the right.



CITY OF AURORA, COLORADO

Chris [Signature] 1/12/10
AURORA WATER DEPARTMENT DATE

Kevin [Signature] 1-14-10
CITY ENGINEER DATE

CULVERT INLET PROTECTION

2 OF 2



STANDARD

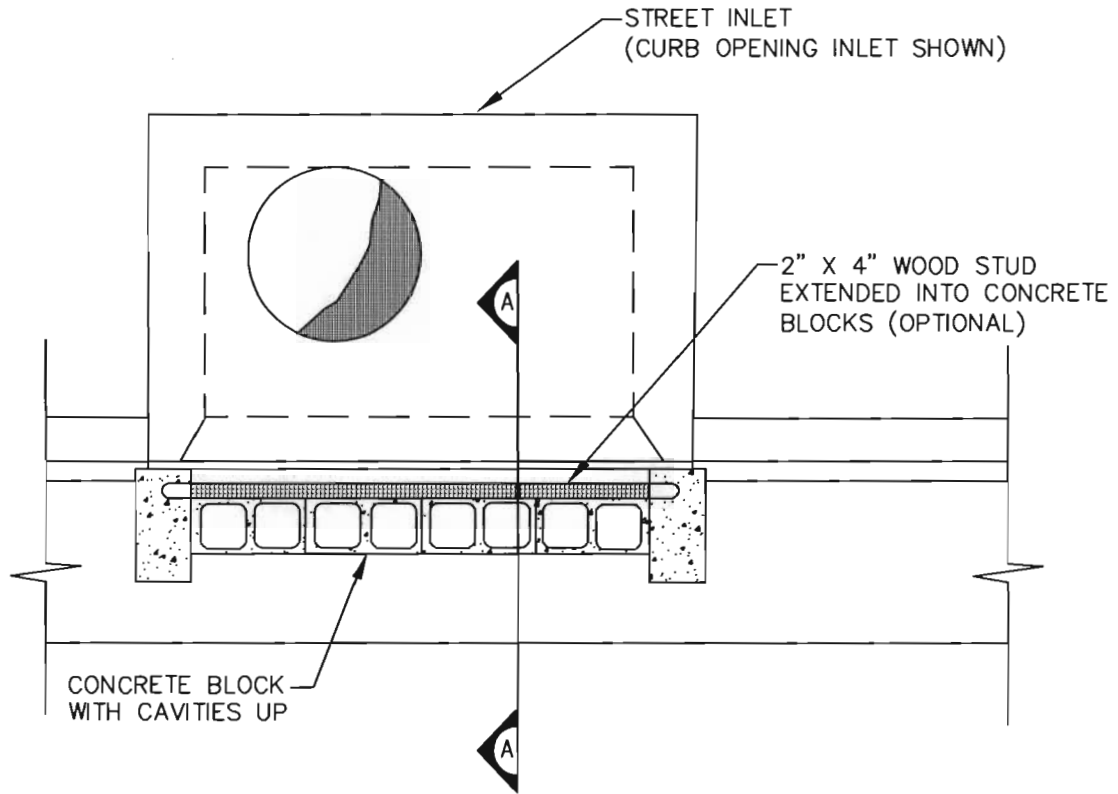

**INTERIM CONFIGURATION
(BEFORE PAVING) STREET INLET-PLAN**

NOT TO SCALE

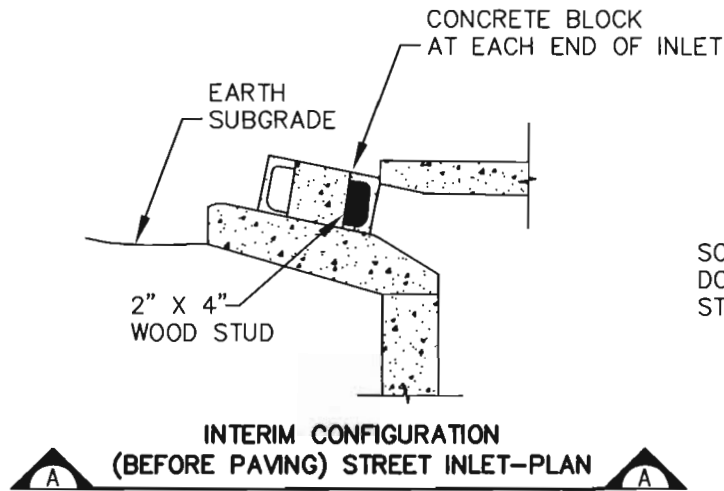

**INTERIM CONFIGURATION
(BEFORE PAVING) STREET INLET-PLAN**

NOT TO SCALE

SOURCE: ADAPTED FROM
DOUGLAS COUNTY GESC
STANDARD DETAILS

NOTE:
THIS CURB INLET PROTECTION APPLIES TO ALL NEWLY INSTALLED STORM INLETS ON STREETS THAT HAVE NOT YET BEEN PAVED. ONCE PAVED, THE APPROPRIATE TYPE OF INLET PROTECTION SHALL BE INSTALLED (IPO, IPS).

CITY OF AURORA, COLORADO

Chris Steiner
AURORA WATER DEPARTMENT

9/1/10
DATE

Chris Wegener
CITY ENGINEER

9.2.10
DATE

(INTERIM) INLET PROTECTION

1 OF 2



STANDARD

Interim Inlet Protection – is installed after an inlet is poured and prior to paving. Concrete blocks or rock wattles blocking the throat will prevent large clumps of dirt from entering the storm sewer during road grading and other construction activities. This temporary feature should be modified to include a rock wattle and the concrete block installation depicted in the IPS or IPO Standard, after paving is initiated.

Key Installation and Maintenance Requirements:

- Broken or damaged blocks and rock wattles require replacement or repairs

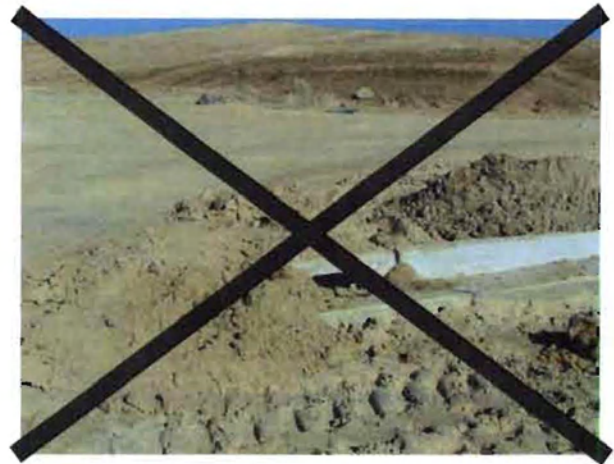
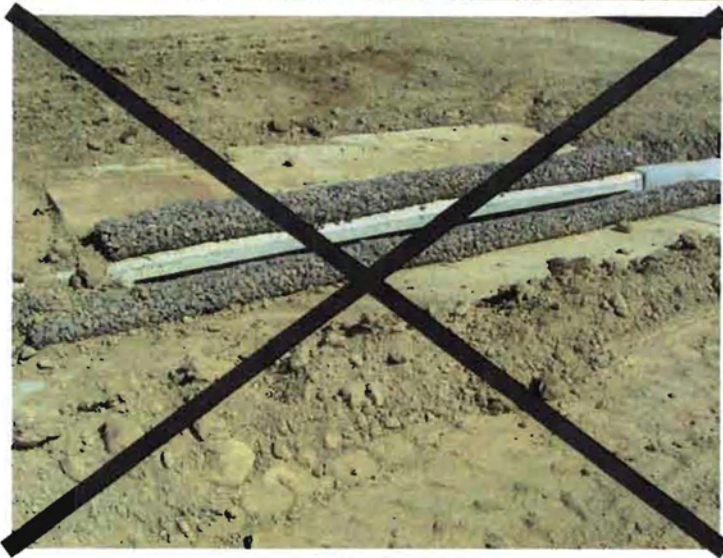

Unprotected inlets can easily be impacted with sediment.

CITY OF AURORA, COLORADO

Chris 28th 1/12/10
AURORA WATER DEPARTMENT DATE

Kevin Wegener 1.14.10
CITY ENGINEER DATE

(INTERIM) INLET PROTECTION

2 OF 2



STANDARD

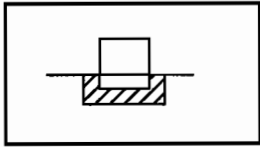

- NOTES:
 1. ROCK SOCKS SHALL BE 1 1/2" CRUSHED ROCK FILL (RECYCLED CONCRETE NOT ACCEPTABLE)

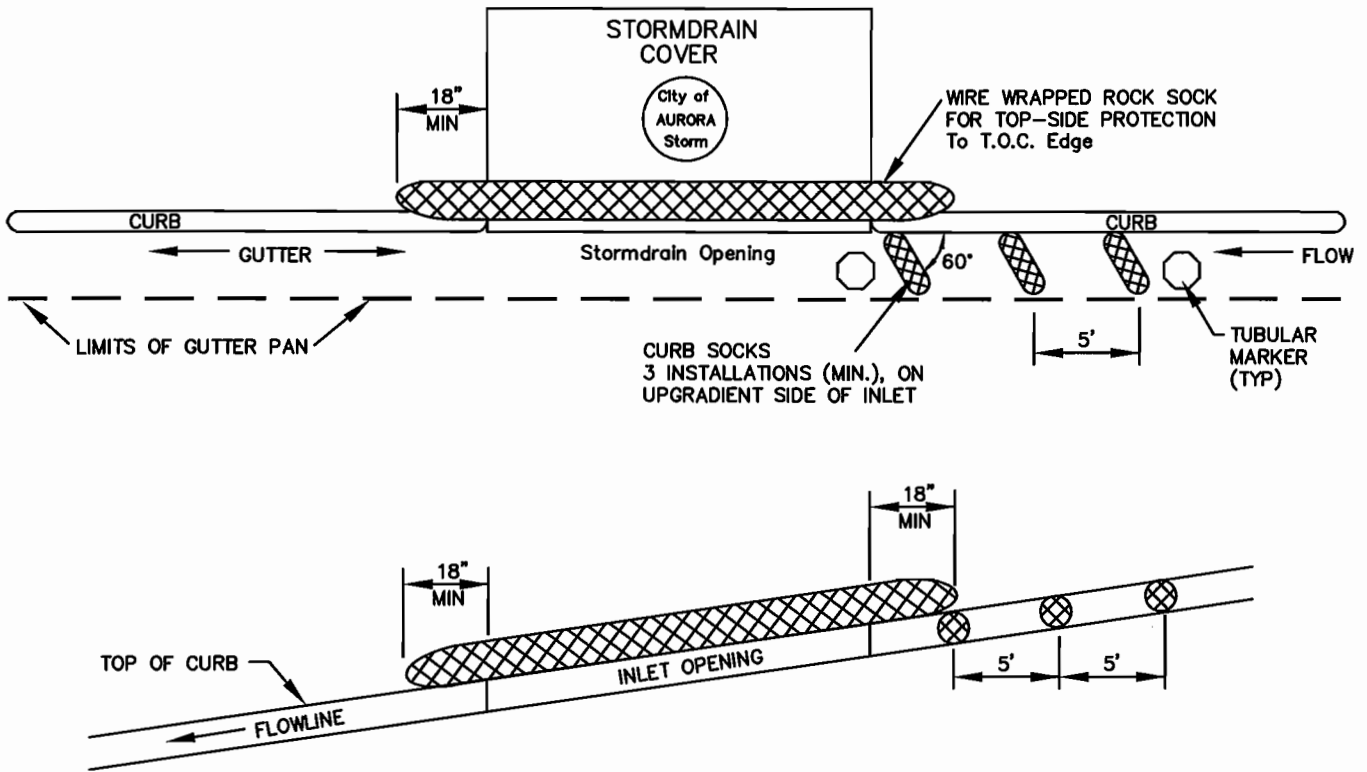

INLET PROTECTION INSTALLATION NOTES

1. INTERIM CONFIGURATION OF INLET PROTECTION IN STREETS SHALL BE INSTALLED WITHIN 72-HOURS OF POURING INLET.
2. CRUSHED ROCK SHALL BE FRACTURED FACE (ALL SIDES) AND SHALL BE 1 1/2" CRUSHED ROCK.
3. WIRE MESH SHALL BE FABRICATED OF MINIMUM 16-20 GAUGE WIRE TWISTED INTO A MESH WITH A MAXIMUM OPENING OF 1/2 INCH. 16-20 GAUGE CHICKEN WIRE MAY BE USED IF DOUBLE WRAPPED WITH NO MORE THAN 1/2" OPENINGS. ROLL WIDTH SHALL BE 48"
4. WIRE MESH SHALL BE SECURED USING "HOG RINGS" OR WIRE TIES AT 6" CENTERS ALONG ALL JOINTS AND AT 2" CENTERS ON ENDS OF ROCK SOCKS.
5. ROCK SOCK SHALL BE CONSTRUCTED IN ONE PIECE.
6. TUBULAR MARKERS SHALL MEET REQUIREMENTS OF MANUAL ON UNIFORM TRAFFIC CONTROL DEVICES (MUTCD), AS AMENDED.
7. THE TOP OF THE REINFORCED ROCK SOCK SHALL BE 1/2" - 1" BELOW TOP OF CURB.
8. SEDIMENT ACCUMULATED UPSTREAM OF THE INLET PROTECTION SHALL BE REMOVED WHEN THE SEDIMENT DEPTH UPSTREAM OF ROCK SOCK IS WITHIN 3" OF THE CREST.
9. INLET PROTECTION IS TO REMAIN IN PLACE UNTIL THE UPSTREAM DISTURBED AREA IS STABILIZED AND GRASS COVER IS APPROVED.
10. REFER TO (CS) & (RS) DETAILS FOR MORE INFORMATION.

STREET SLOPE	CURB SOCK SPACING (ft)
0.5%	100
1.0%	100
2.0%	75
3.0%	50
4.0%	50
5.0%	50
6.0%	25
7.0%	25
8.0%	25

NOTE:
 THIS CURB SOCK SPACING IS IN ADDITION TO THE 3 CURB SOCKS REQUIRED AT THE INLET.

CITY OF AURORA, COLORADO

Clay 2 Sten 11/5/10
 AURORA WATER DEPARTMENT DATE
Kevin Wegener 11.9.10
 CITY ENGINEER DATE

ON-GRADE INLET LOCATION
 INLET PROTECTION

1 OF 2



STANDARD

On-grade Inlet Protection - consists of small sections of rock wattles installed as curb-socks, which are intended to trap sediment upstream of an inlet without causing or allowing any bypass of flow around the inlet.

Key Installation and Maintenance Requirements:

- Rock wattles should be constructed and maintained to a minimum diameter of 6"
- Broken or damaged rock wattles require replacement or repairs
- Features require on-going monitoring to ensure correct alignment and function.



Inappropriate applications will allow flows to by-pass the feature, potentially overwhelming the downgradient storm inlet.

CITY OF AURORA, COLORADO

Chris 2.9.10 4/12/10
AURORA WATER DEPARTMENT DATE

Kevin W. Jensen 1.14.10
CITY ENGINEER DATE

ON-GRADE INLET LOCATION
INLET PROTECTION

2 OF 2



STANDARD



NOTES:
 1. ROCK SOCK SHALL BE 1 1/2" CRUSHED ROCK FILL (RECYCLED CONCRETE NOT ACCEPTABLE)

* BOTH SIDES OF INLET

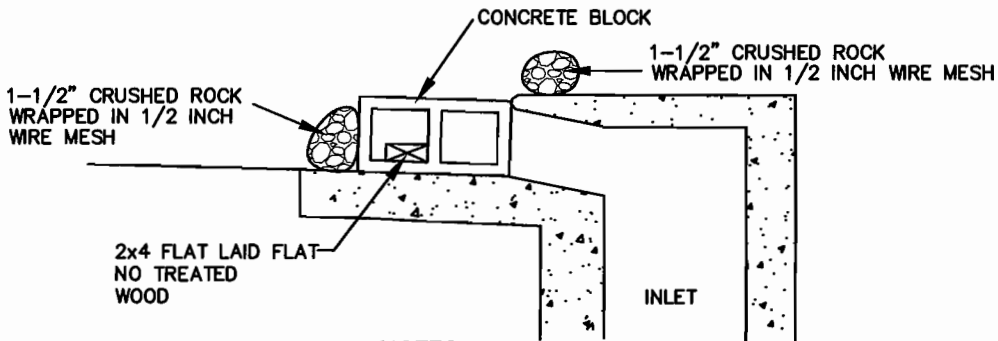
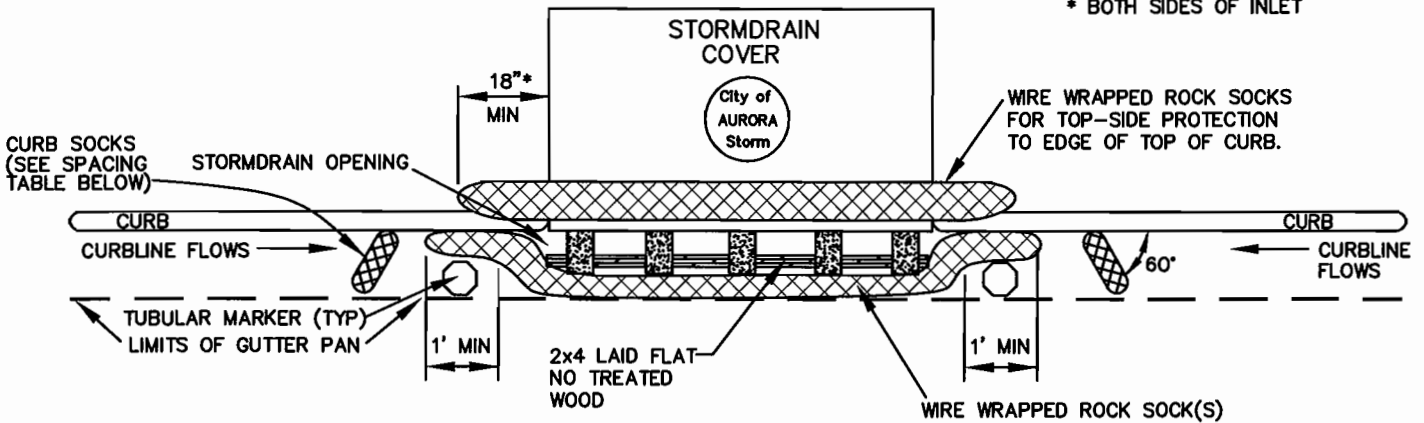

NOTES:

1. INTERIM CONFIGURATION OF INLET PROTECTION IN STREETS SHALL BE INSTALLED WITHIN 72-HOURS OF POURING INLET.
2. CRUSHED ROCK SHALL BE FRACTURED FACE (ALL SIDES) AND SHALL BE 1 1/2" CRUSHED ROCK.
3. WIRE MESH SHALL BE FABRICATED OF MINIMUM 16-20 GAUGE WIRE TWISTED INTO A MESH WITH A MAXIMUM OPENING OF 1/2 INCH. ROLL WIDTH SHALL BE 48". 16-20 GAUGE CHICKEN WIRE MAY BE USED IF DOUBLE WRAPPED WITH NO MORE THAN 1/2" OPENINGS.
4. WIRE MESH SHALL BE SECURED USING "HOG RINGS" OR WIRE TIES AT 6" CENTERS ALONG ALL JOINTS AND AT 2" CENTERS ON ENDS OF ROCK SOCKS.
5. ROCK SOCK SHALL BE CONSTRUCTED IN ONE PIECE OR SHALL BE CONSTRUCTED USING ROCK SOCK JOINT DETAIL.
6. TUBULAR MARKERS SHALL MEET REQUIREMENTS OF MANUAL ON UNIFORM TRAFFIC CONTROL DEVICES (MUTCD), AS AMENDED.
7. THE TOP OF THE REINFORCED ROCK SOCK SHALL BE 1/2" - 1" BELOW TOP OF CURB.
8. SEDIMENT ACCUMULATED UPSTREAM OF THE INLET PROTECTION SHALL BE REMOVED WHEN THE SEDIMENT DEPTH UPSTREAM OF ROCK SOCK IS WITHIN 5" OF THE CREST.
9. INLET PROTECTION IS TO REMAIN IN PLACE UNTIL THE UPSTREAM DISTURBED AREA IS STABILIZED AND GRASS COVER IS APPROVED.
10. REFER TO (CS) AND (RS) DETAILS FOR MORE INFO.

STREET SLOPE	CURB SOCK SPACING (ft)
0.5%	100
1.0%	100
2.0%	75
3.0%	50
4.0%	50
5.0%	50
6.0%	25
7.0%	25
8.0%	25

CITY OF AURORA, COLORADO

Clay Ste 11/9/10
 AURORA WATER DEPARTMENT DATE

Kevin Wegener 11.9.10
 CITY ENGINEER DATE

SUMP INLET LOCATION
 INLET PROTECTION

1 OF 2



STANDARD

Sump Inlet Protection - is intended to maintain inlet capacity by allowing flows to convey over or through the wire-enclosed rock wattle. In some locations of sump and on-grade inlets, topside protection should be provided for inlets, specifically for those inlets that are bordered by disturbed areas. Such top-side protection should consist of barriers installed to control sediment-laden flows from entering from the top of the inlet opening.

Key Installation and Maintenance Requirements:

- Rock wattles should be constructed and maintained to a minimum diameter of 6"
- Broken or damaged concrete blocks and rock wattles require replacement or repairs



Features that are not installed correctly and/or not maintained in place cannot function as intended. Note the open ends in the example here, with sediment-laden flows discharging directly into the stormdrain.



CITY OF AURORA, COLORADO

Chris [Signature] 1/15/10
AURORA WATER DEPARTMENT DATE

Kevin Wegener 1-15-10
CITY ENGINEER DATE

SUMP INLET LOCATION
INLET PROTECTION

2 OF 2



STANDARD

1. During the Excavation and Foundation phase, if excavated soils are to be placed on an adjacent lot instead of within the same lot, then COA standard perimeter BMPs will be required on the adjacent lot.
2. Lot access tracking control may be consist of one of the following:
 - a. Angular rock, minimum ¾", with or without a geotextile underlayment.
 - b. High strength geo-grid with a geotextile underlayment.
 - c. High strength manufactured mobile mat systems of bamboo, or plastic.

Due to high failure rates, turf reinforcement mat and erosion control blanket shall not be used as a lot access tracking control feature.
3. Surface roughening shall be applied to disturbed lots throughout excavation and vertical construction phases to reduce sediment migration.
4. Other standard City of Aurora perimeter controls for silt fence or SCL may be approved by a COA Environmental Inspector. Any substitutions that are not a current COA standard detail will require a variance request and approval prior to installation.
5. When an occupied property or a landscaped property is down gradient from an active lot, a BMP shall be placed along the property line between the two lots. The BMP shall consist of silt fence, sediment control log, rock sock, or other COA standard perimeter BMP. Do not install silt fence within dripline of existing trees.
6. Reinforced silt fence will be required at the rear or side of a lot when the lot is adjacent to a water body (stream, detention pond, water quality pond, etc). SFR detail shall be utilized. Do not install silt fence within dripline of existing trees.
7. When a vacant vegetated lot (temporary or native, but to be disturbed as part of overall development) or vacant disturbed lot is down gradient from an active lot, the active lot shall be surface roughened along the adjacent property line until final swales are graded and erosion control blanket BMPs can be installed. Additional BMPs may be required along adjacent lot line if sediment migration is occurring.
8. When a disturbed tree lawn area is present, silt fence or other COA standard perimeter BMPs shall be placed at the back of the sidewalk. Sediment control logs or other COA standard perimeter BMPs shall be placed at the back of the curb. As an alternative to sediment control logs or silt fence, erosion control blankets can be placed across the width of the tree lawn area. ECB in this application does not require trenching. If the tree lawn is final stabilized, no back of curb BMP is required.
9. Final stage and tree lawn installations of ECB may be installed parallel along property lot lines. Metal pins may be used for staking if installation is temporary (1 year or less).
10. Sediment control logs, silt fence, erosion control blankets or other COA standard perimeter BMP shall be placed at the back of sidewalk as a temporary BMP until the front yard landscaping is installed. The exact layout of the landscaping will be determined based on approved landscape plans.
11. Curb socks shall be placed down gradient from active lots and throughout all active areas. There shall be a minimum of three curb socks downhill from any active lot per the curb sock detail spacing table or to the nearest inlet protection, whichever is less.
12. A rock sock may need to be placed across the sidewalk when the downstream lot is landscaped. The rock sock shall be placed on the sidewalk bridging the area between back of sidewalk BMPs and back of curb/side lot BMPs. A marker or barricade shall be placed at the rock sock to indicate a (trip) hazard.

CITY OF AURORA, COLORADO

Chris J. Spivey 11/5/10
AURORA WATER DEPARTMENT DATE

Kevin W. Jensen 11-9-10
CITY ENGINEER DATE

SINGLE FAMILY LOT
EROSION CONTROL PLAN
NOTES

1 OF 11



STANDARD

13. Time of year construction (winter, spring, etc) shall be taken into consideration and the appropriate BMPs shall be selected.
14. Portable toilets and trash dumpsters shall be located behind perimeter BMPs at all times.
15. Masonry mixers and materials and liquid waste washouts shall be behind perimeter BMPs at all times, and provided with secondary containment.
16. Small liquid waste washouts may be spaced one for every three contiguous lots under construction at the same time.
17. On walkout (W) and garden (G) level lots, erosion control blankets shall be used on the steep grade change slope.
18. Perimeter BMPs may be removed or pulled back for short periods of time for deliveries or active grading, but shall be replaced as soon as activities cease even temporarily, before any precipitation event, or by the end of the day, whichever occurs first.
19. The final construction stage addresses BMPs that are required prior to final landscaping and stabilization.

CITY OF AURORA, COLORADO

Craig S. Stone 11/5/10
AURORA WATER DEPARTMENT DATE

Kevin Wegener 11.9.10
CITY ENGINEER DATE

SINGLE FAMILY LOT
EROSION CONTROL PLAN
NOTES

2 OF 11

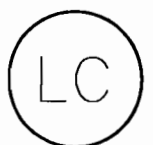

STANDARD

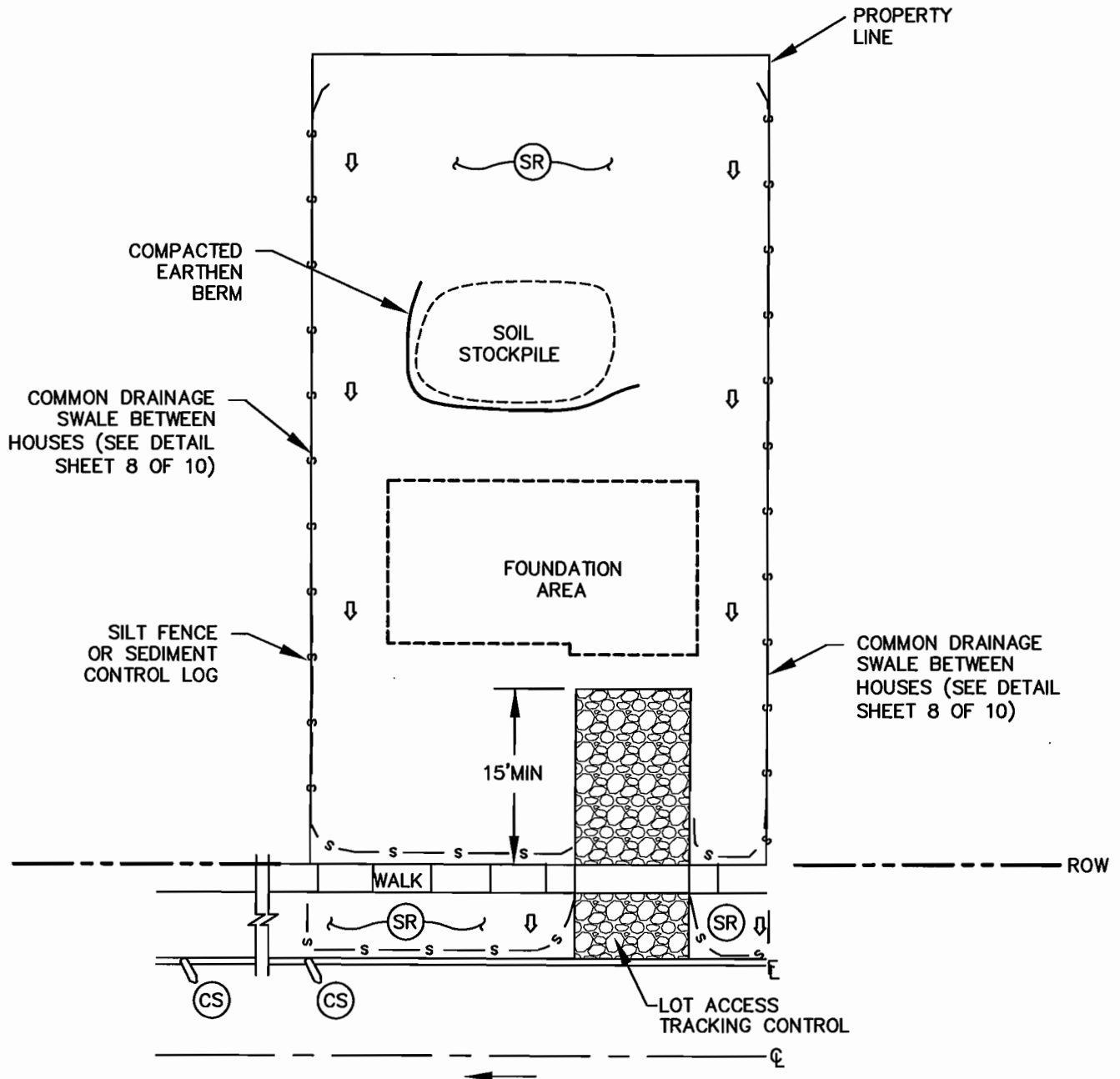

NOTES:

1. OTHER PERIMETER CONTROLS MAY BE APPROVED BY A C.O.A. ENVIRONMENTAL INSPECTOR/SUPERVISOR.
2. SURFACE ROUGHENING IS REQUIRED AS AN INTERIM STABILIZATION WHEN ACTIVE GRADING CEASES, EVEN TEMPORARILY
3. UP TO 3 LOTS MAY BE INCLUDED IN 1 SET OF PERIMETER CONTROLS AS LONG AS THEY ARE PROCEEDING AT THE SAME PROCESS OF CONSTRUCTION.
4. EACH INDIVIDUAL LOT WILL VARY AND THIS DETAIL IS INTENDED AS A GUIDELINE.

—s— SILT FENCE / SEDIMENT CONTROL LOG
 ⇨ DIRECTION OF SURFACE WATER RUNOFF

CITY OF AURORA, COLORADO
Clayton S. ... 11/5/10
 AURORA WATER DEPARTMENT DATE
Kevin Wegener 11.9.10
 CITY ENGINEER DATE

SINGLE FAMILY LOT
 EROSION CONTROL PLAN
 TYPE A
 EXCAVATION & FOUNDATION PLAN



STANDARD

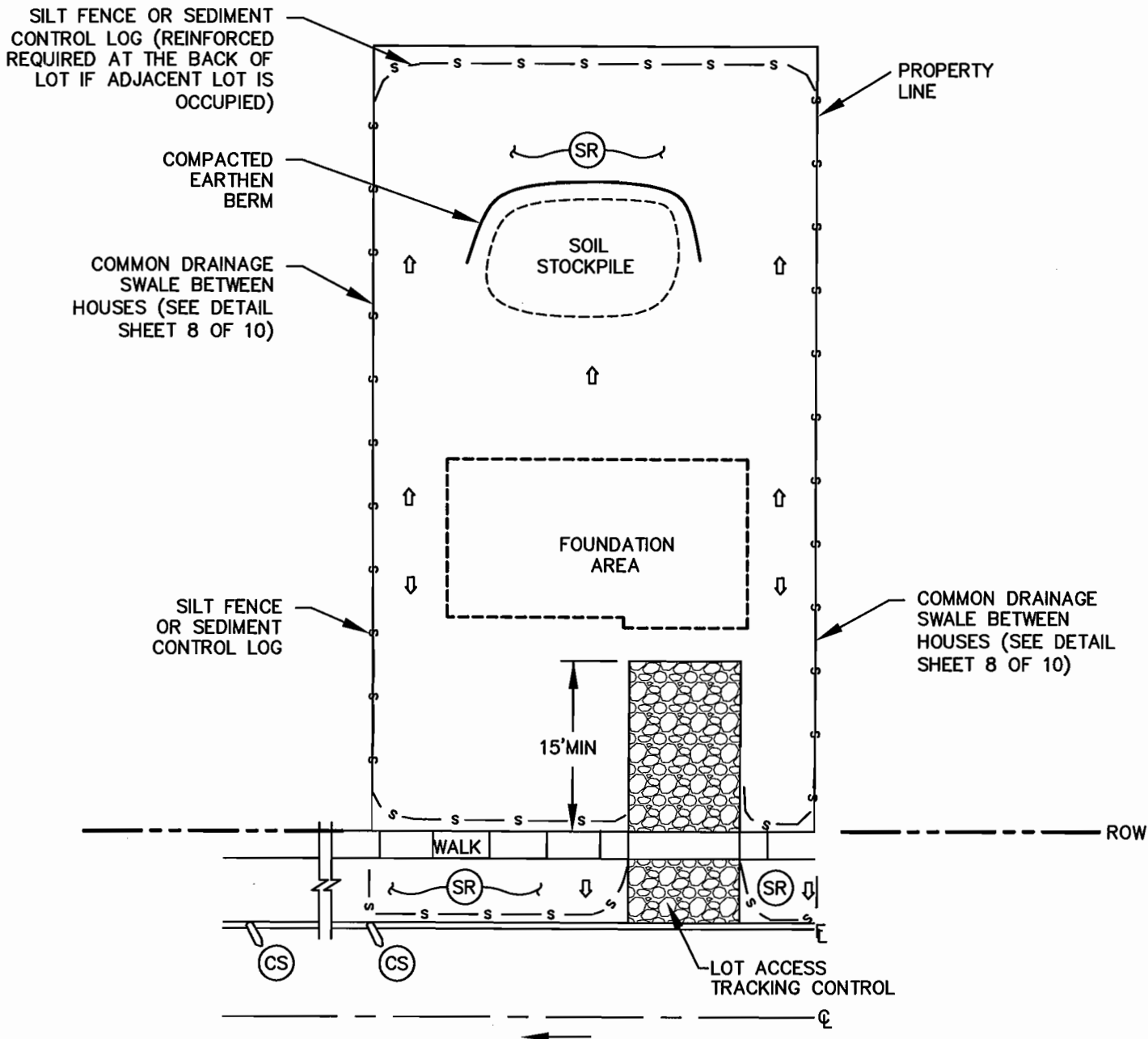

NOTES:

1. OTHER PERIMETER CONTROLS MAY BE APPROVED BY A C.O.A. ENVIRONMENTAL INSPECTOR/SUPERVISOR.
2. SURFACE ROUGHENING IS REQUIRED AS AN INTERIM STABILIZATION WHEN ACTIVE GRADING CEASES, EVEN TEMPORARILY
3. UP TO 3 LOTS MAY BE INCLUDED IN 1 SET OF PERIMETER CONTROLS AS LONG AS THEY ARE PROCEEDING AT THE SAME PROCESS OF CONSTRUCTION.
4. EACH INDIVIDUAL LOT WILL VARY AND THIS DETAIL IS INTENDED AS A GENERAL GUIDELINE.

—s— SILT FENCE / SEDIMENT CONTROL LOG
 ⇨ DIRECTION OF SURFACE WATER RUNOFF

CITY OF AURORA, COLORADO

Clayton St 11/5/10
 AURORA WATER DEPARTMENT DATE
Kevin Wegener 11.9.10
 CITY ENGINEER DATE

SINGLE FAMILY LOT
 EROSION CONTROL PLAN
 TYPE B/G/W
 EXCAVATION & FOUNDATION PLAN

4 OF 11



STANDARD

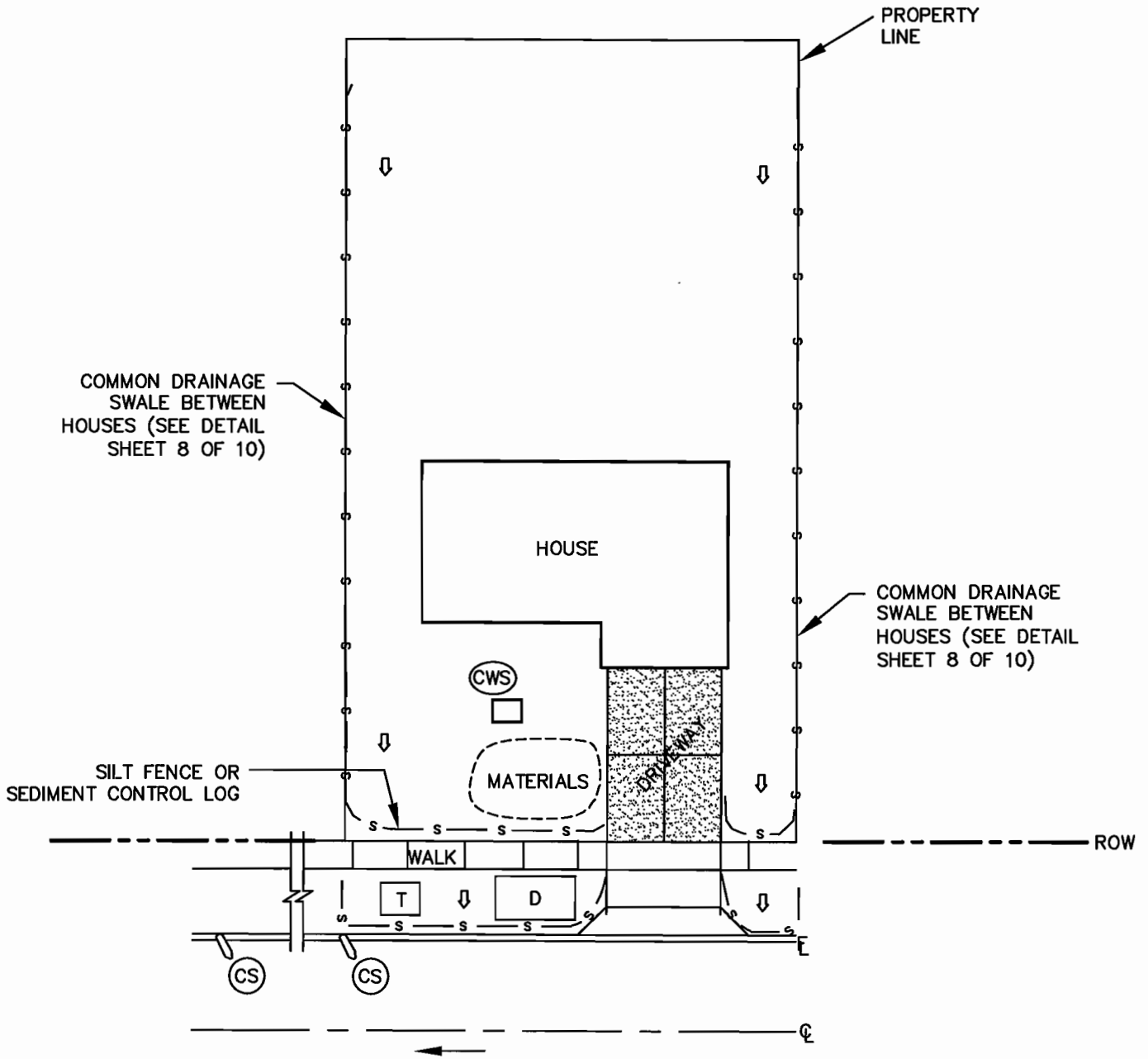

NOTES:

1. MASONRY MIXERS AND MATERIALS AND LIQUID WASTE WASHOUTS SHALL BE BEHIND PERIMETER CONTROLS AT ALL TIMES, AND PROVIDED WITH SECONDARY CONTAINMENT.
2. OTHER PERIMETER CONTROLS MAY BE APPROVED BY A C.O.A. ENVIRONMENTAL INSPECTOR/SUPERVISOR.
3. ONE CWS MAY BE USED FOR UP TO 3 CONTIGUOUS LOTS.
4. SURFACE ROUGHENING IS REQUIRED AS AN INTERIM STABILIZATION WHEN ACTIVE GRADING CEASES, EVEN TEMPORARILY.
5. EACH INDIVIDUAL LOT WILL VARY AND THIS DETAIL IS INTENDED AS A GENERAL GUIDELINE.
6. LOCATE MIXING STATION ON LIVING DOCUMENT. A DETAIL OF MIXING STATION BMP'S MUST BE PROVIDED TO THE COA ENVIRONMENTAL INSPECTOR/SUPERVISOR FOR APPROVAL.

- s— SILT FENCE / SEDIMENT CONTROL LOG
- ⇨ DIRECTION OF SURFACE WATER RUNOFF
- D TRASH DUMPSTER
- T PORTABLE TOILET
- MS MIXING STATION

CITY OF AURORA, COLORADO

Clay 2 St 11/5/10
 AURORA WATER DEPARTMENT DATE
Karen W. Jensen 11.9.10
 CITY ENGINEER DATE

SINGLE FAMILY LOT
 EROSION CONTROL PLAN
 TYPE A
 BUILDING CONSTRUCTION PLAN

5 OF 11



STANDARD

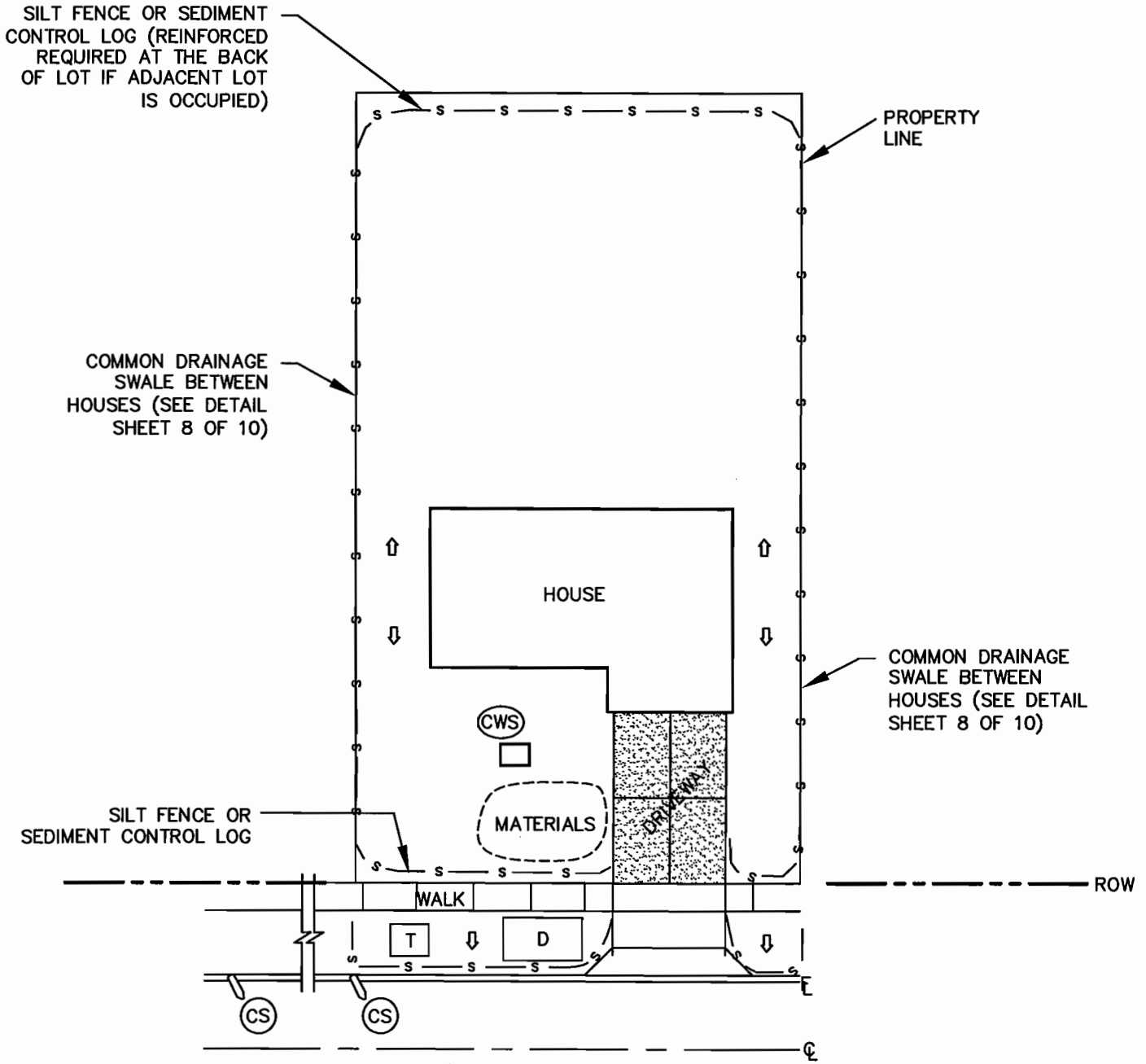

NOTES:

1. MASONRY MIXERS AND MATERIALS AND LIQUID WASTE WASHOUTS SHALL BE BEHIND PERIMETER CONTROLS AT ALL TIMES, AND PROVIDED WITH SECONDARY CONTAINMENT.
2. OTHER PERIMETER CONTROLS MAY BE APPROVED BY A C.O.A. ENVIRONMENTAL INSPECTOR/SUPERVISOR.
3. ONE CWS MAY BE USED FOR UP TO 3 CONTIGUOUS LOTS.
4. SURFACE ROUGHENING IS REQUIRED AS AN INTERIM STABILIZATION WHEN ACTIVE GRADING CEASES, EVEN TEMPORARILY.
5. EACH INDIVIDUAL LOT WILL VARY AND THIS DETAIL IS INTENDED AS A GENERAL GUIDELINE.
6. LOCATE MIXING STATION ON LIVING DOCUMENT. A DETAIL OF MIXING STATION BMP'S MUST BE PROVIDED TO THE COA ENVIRONMENTAL INSPECTOR/SUPERVISOR FOR APPROVAL.

- s— SILT FENCE / SEDIMENT CONTROL LOG
- ⇨ DIRECTION OF SURFACE WATER RUNOFF
- D TRASH DUMPSTER
- T PORTABLE TOILET
- MS MIXING STATION

CITY OF AURORA, COLORADO
Clayton 11/5/10
 AURORA WATER DEPARTMENT DATE
Kevin Wegman 11.9.10
 CITY ENGINEER DATE

SINGLE FAMILY LOT
 EROSION CONTROL PLAN
 TYPE B/G/W
 BUILDING CONSTRUCTION PLAN



STANDARD

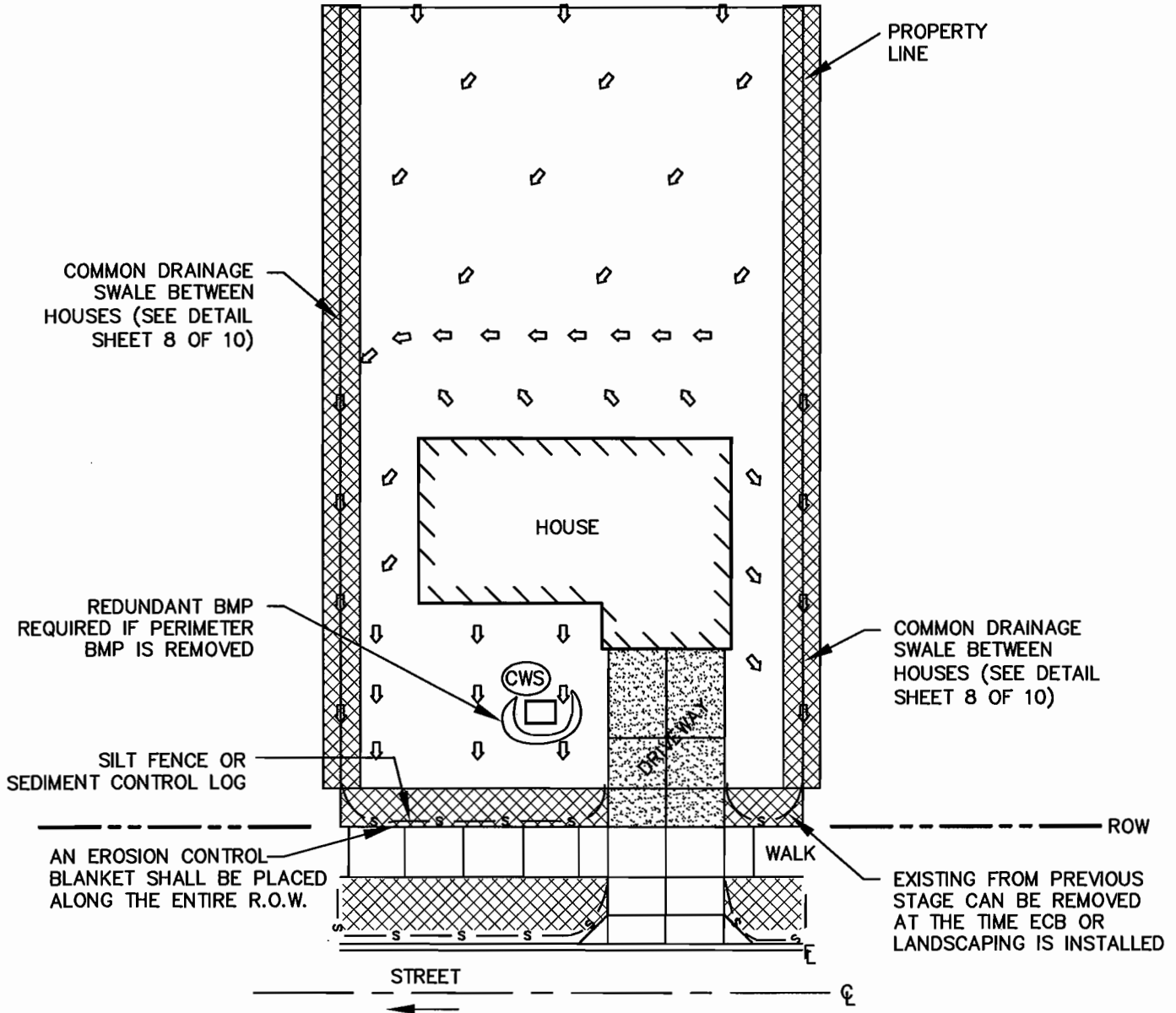

NOTES:

1. MASONRY MIXERS AND MATERIALS AND LIQUID WASTE WASHOUTS SHALL BE BEHIND PERIMETER CONTROLS AT ALL TIMES, AND PROVIDED WITH SECONDARY CONTAINMENT.
2. OTHER PERIMETER CONTROLS MAY BE APPROVED BY A C.O.A. ENVIRONMENTAL INSPECTOR/SUPERVISOR.
3. ECB TO BE INSTALLED AFTER FINE GRADING IS COMPLETE.
4. ONE CWS MAY BE USED FOR UP TO 3 CONTIGUOUS LOTS.
5. SURFACE ROUGHENING IS REQUIRED AS AN INTERIM STABILIZATION WHEN ACTIVE GRADING CEASES.
6. IF FINAL LANDSCAPING IS INSTALLED WITHIN 14 CALENDAR DAYS, THEN ECB MAY NOT BE REQUIRED IN THOSE AREAS OR MAY BE REMOVED.
7. EACH INDIVIDUAL LOT WILL VARY AND THIS DETAIL IS INTENDED AS A GENERAL GUIDELINE.

—s— SILT FENCE / SEDIMENT CONTROL LOG (2)

⇒ DIRECTION OF SURFACE WATER RUNOFF

▨ EROSION CONTROL BLANKET

CITY OF AURORA, COLORADO

Chris 25th 11/5/10
 AURORA WATER DEPARTMENT DATE

Kevin Wegener 11-9-10
 CITY ENGINEER DATE

SINGLE FAMILY LOT
 EROSION CONTROL PLAN
 FINAL STAGE TYPE A

7 OF 11

LC

STANDARD

SILT FENCE OR SEDIMENT CONTROL LOG (REINFORCED REQUIRED AT BACK OF LOT IF ADJACENT LOT IS OCCUPIED)

COMMON DRAINAGE SWALE BETWEEN HOUSES (SEE DETAIL SHEET 8 OF 10)

REDUNDANT BMP REQUIRED IF PERIMETER BMP IS REMOVED

SILT FENCE OR SEDIMENT CONTROL LOG

PROPERTY LINE

COMMON DRAINAGE SWALE BETWEEN HOUSES (SEE DETAIL SHEET 8 OF 10)

EXISTING FROM PREVIOUS STAGE CAN BE REMOVED AT THE TIME ECB OR LANDSCAPING IS INSTALLED

AN EROSION CONTROL BLANKET SHALL BE PLACED ALONG THE ENTIRE R.O.W.

NOTES:

1. MASONRY MIXERS AND MATERIALS AND LIQUID WASTE WASHOUTS SHALL BE BEHIND PERIMETER CONTROLS AT ALL TIMES, AND PROVIDED WITH SECONDARY CONTAINMENT.
2. OTHER PERIMETER CONTROLS MAY BE APPROVED BY A C.O.A. ENVIRONMENTAL INSPECTOR/SUPERVISOR.
3. ECB TO BE INSTALLED AFTER FINE GRADING IS COMPLETE.
4. ONE CWS MAY BE USED FOR UP TO 3 CONTIGUOUS LOTS.
5. SURFACE ROUGHENING IS REQUIRED AS AN INTERIM STABILIZATION WHEN ACTIVE GRADING CEASES.
6. IF FINAL LANDSCAPING IS INSTALLED WITHIN 14 CALENDAR DAYS, THEN ECB MAY NOT BE REQUIRED IN THOSE AREAS OR BE REMOVED.
7. EACH INDIVIDUAL LOT WILL VARY AND THIS DETAIL IS INTENDED AS A GENERAL GUIDELINE.

—s— SILT FENCE / SEDIMENT CONTROL LOG

⇨ DIRECTION OF SURFACE WATER RUNOFF

 EROSION CONTROL BLANKET

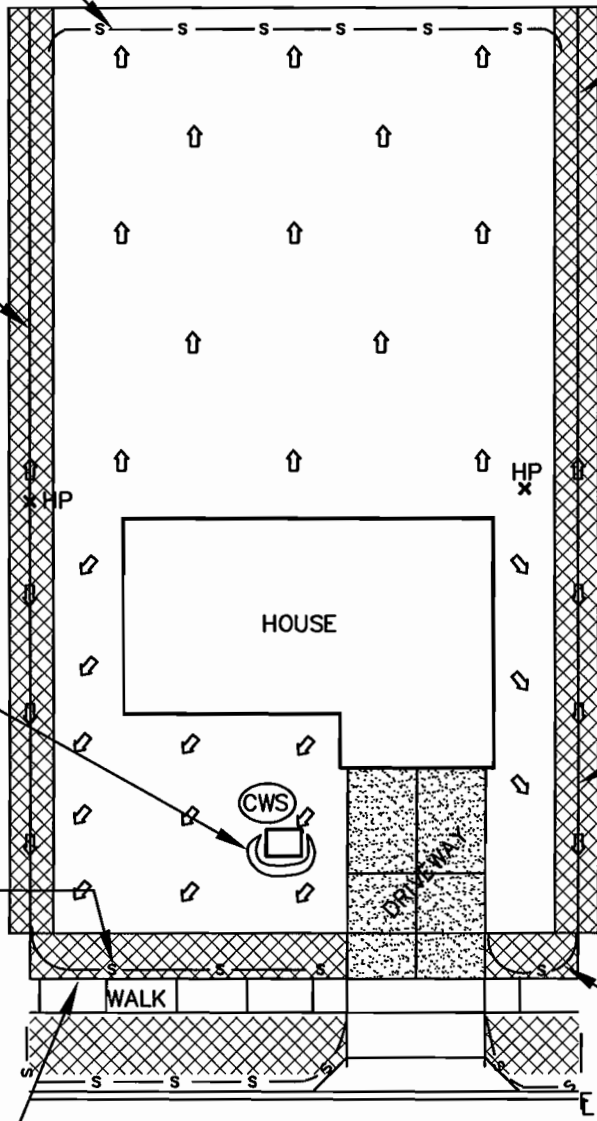

CITY OF AURORA, COLORADO

Chia 2 Str 11/9/10
AURORA WATER DEPARTMENT DATE

Kevin Weisner 11-9-10
CITY ENGINEER DATE

SINGLE FAMILY LOT
EROSION CONTROL PLAN
FINAL STAGE TYPE B/G/W
GARDEN LEVEL & WALKOUT

8 OF 11

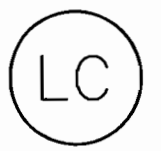

STANDARD

COMMON DRAINAGE SWALE AND DOWNSPOUT PROTECTION DETAIL (BETWEEN HOUSES)

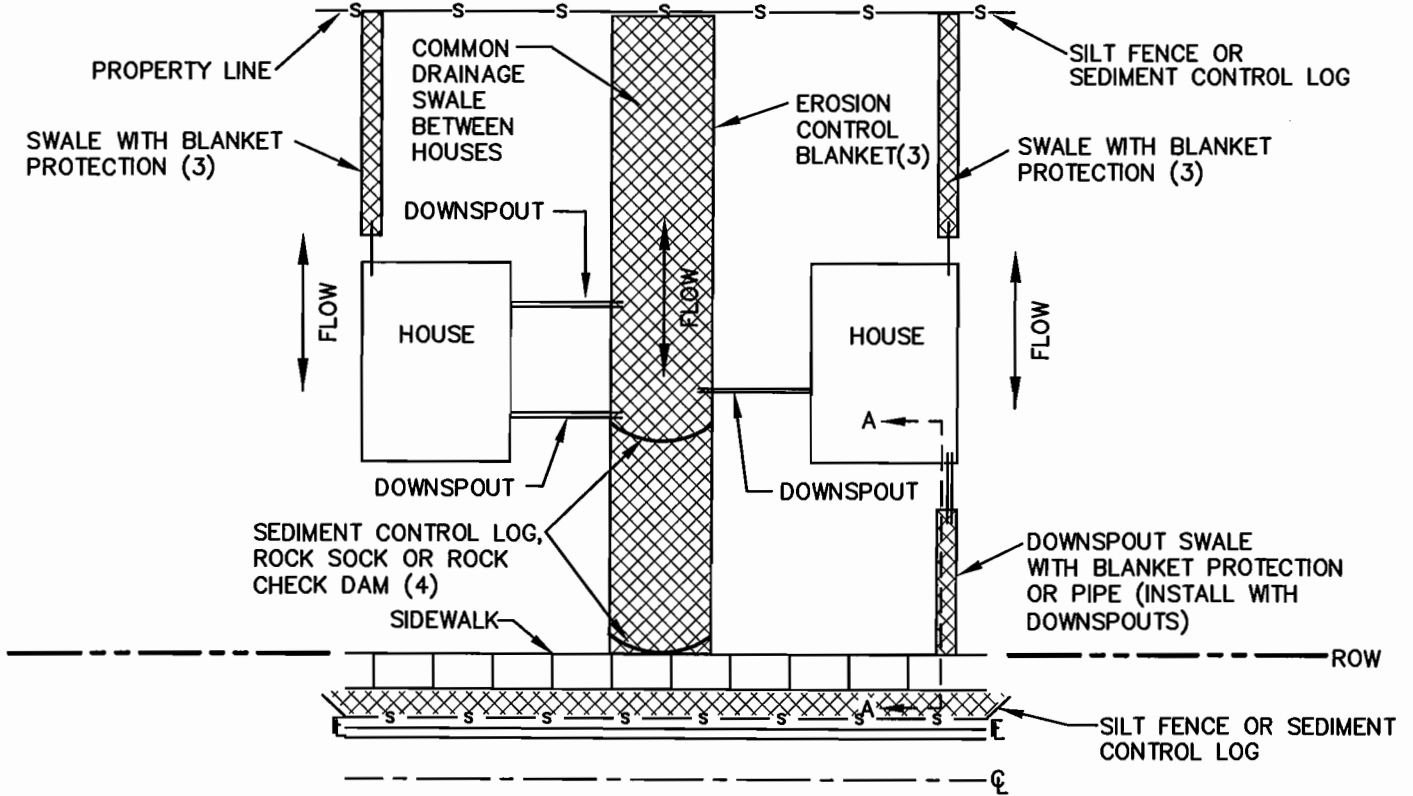

NOTE: EROSION CONTROLS MUST BE IMPLEMENTED AT THE TIME DOWNSPOUTS ARE INSTALLED ON HOUSE

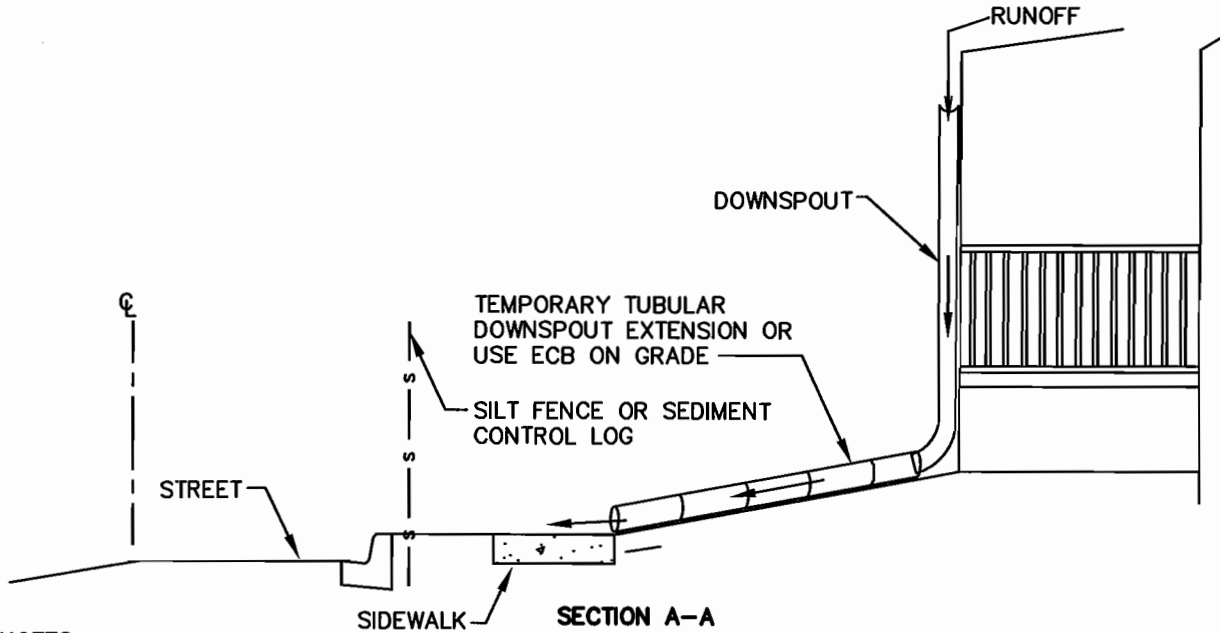

NOTES:

1. ALTERNATIVE METHODS OF EROSION PROTECTION FROM DOWNSPOUTS MAY BE APPROVED BY THE COA INSPECTOR. ALTERNATIVE METHODS MUST DIRECT FLOW FROM DOWNSPOUTS TO WALK, GUTTER OR OTHER STABILIZED AREA WITHOUT CAUSING EROSION.
2. OTHER PERIMETER CONTROLS MAY BE APPROVED BY A C.O.A. ENVIRONMENTAL INSPECTOR/SUPERVISOR.
3. ECB FOR SWALES TO BE INSTALLED WITHIN 72 HOURS AFTER FINE GRADING IS COMPLETE.
4. SURFACE ROUGHENING IS REQUIRED AS AN INTERIM STABILIZATION WHEN ACTIVE GRADING CEASES, EVEN TEMPORARILY.
5. INSTALL SCL, RS, OR CD ONCE SWALE IS GRADED. EACH INDIVIDUAL LOT WILL VARY AND THIS DETAIL IS INTENDED AS A GENERAL GUIDELINE.
6. INTENDED AS A GENERAL GUIDELINE.

CITY OF AURORA, COLORADO
Clim 2 Star 11/5/10
 AURORA WATER DEPARTMENT DATE
Klein Wegener 11.9.10
 CITY ENGINEER DATE

SINGLE FAMILY LOT
 EROSION CONTROL PLAN
 DETAILS

9 OF 11

STANDARD

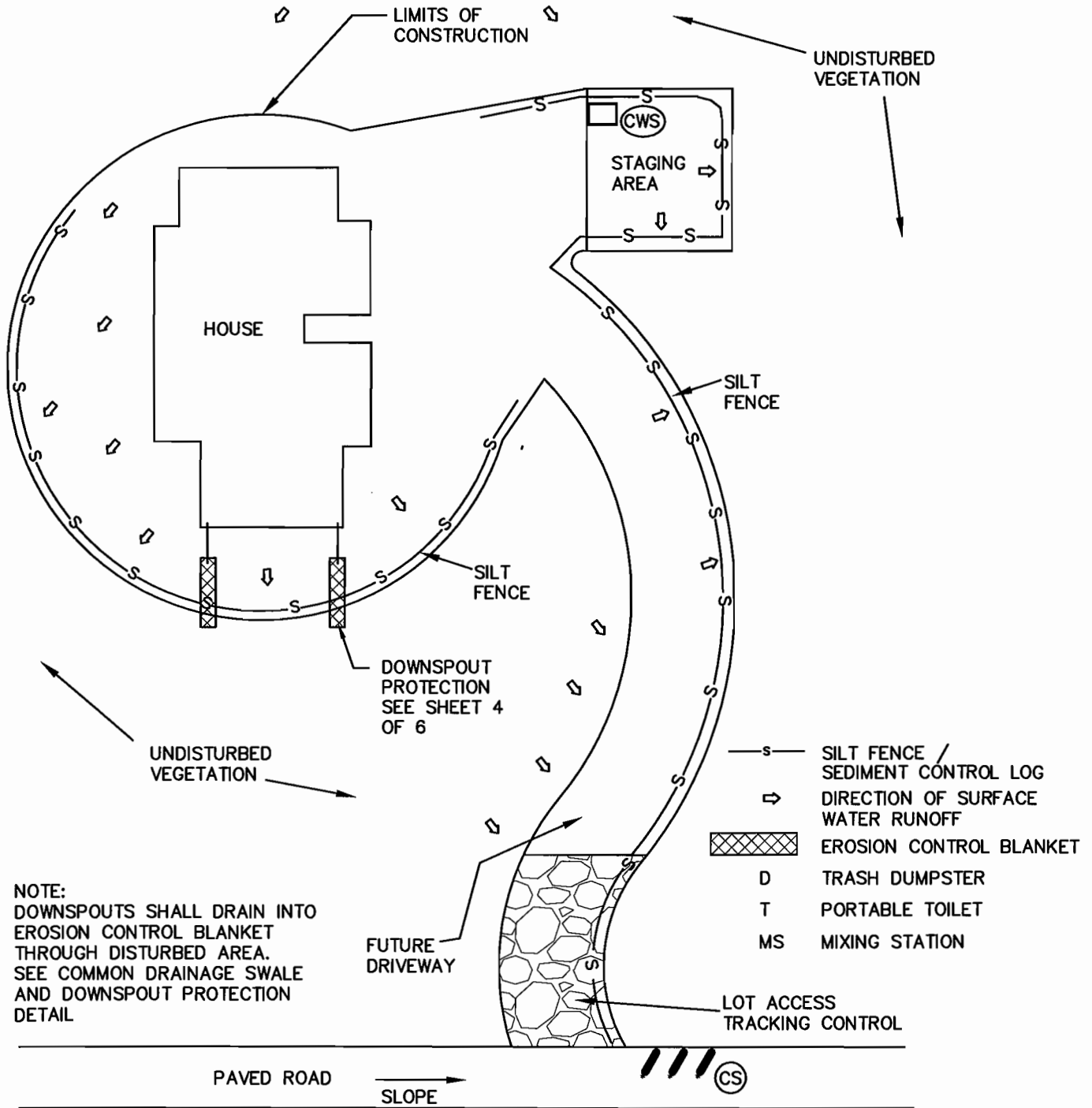

NOTES:

1. MASONRY MIXERS AND MATERIALS AND LIQUID WASTE WASHOUTS SHALL BE BEHIND PERIMETER CONTROLS AT ALL TIMES, AND PROVIDED WITH SECONDARY CONTAINMENT.
2. OTHER PERIMETER CONTROLS MAY BE APPROVED BY A C.O.A. ENVIRONMENTAL INSPECTOR/SUPERVISOR.
3. ECB TO BE INSTALLED AFTER FINE GRADING IS COMPLETE.
4. SURFACE ROUGHENING IS REQUIRED AS AN INTERIM STABILIZATION WHEN ACTIVE GRADING CEASES, EVEN TEMPORARILY.
5. THIS PLAN MAY BE USED WHEN ONLY PART OF THE LOT IS DISTURBED.
6. SILT FENCE MUST BE PLACED DOWN STREAM FROM ALL AREAS TO BE DISTURBED.
7. EACH INDIVIDUAL LOT WILL VARY AND THIS DETAIL IS INTENDED AS A GENERAL GUIDELINE.

CITY OF AURORA, COLORADO

Clayton Stan 11/5/10
 AURORA WATER DEPARTMENT DATE

Kevin Wegener 11-9-10
 CITY ENGINEER DATE

SINGLE FAMILY LOT
 EROSION CONTROL PLAN
 LARGE LOT

10 OF 11

LC

STANDARD

Lot Perimeter Controls - shall be used during construction to assist in containing the site and controlling the migration of soils and other pollutants onto paved sections or off the boundary. These features will be installed on the roadway and paved surface facing boundaries of all construction sites where disturbed areas adjoin paved sections. Where sidewalks are present, installations are required on the property side of the sidewalk as well as at the curb. Perimeter controls are also required at the rear and side boundaries of lots where the grade is such that drainage will convey to those sections. These temporary boundaries may consist of sediment logs/wattles, silt fencing, erosion control blankets, or other installations that the COA accepts as effective. Installations of perimeter controls are required after new paved sections have been set. Installations of perimeter controls (interior or otherwise) are required to be maintained in place until vegetative cover has been adequately established in areas adjoining paved sections.

Post construction, when final grade has been achieved on the lot, erosion control blankets will be installed at all downspout locations and in drainage swales, if these areas are not immediately landscaped. If sod or other final landscaping is not installed, features shall be maintained in place and conveyed to the new owner.

Key Installation and Maintenance Requirements:

- Installation and maintenance guidelines for other approved features (silt fencing, erosion control mats or other) should be as directed for that feature in other standard details.



Areas of disturbance that do not have adequate sediment barriers installed at the perimeter can easily convey sediment onto paved sections or off-site. Features need to be installed and maintained in place to provide lot protection.

CITY OF AURORA, COLORADO

Clay 2 Str 11/5/10
AURORA WATER DEPARTMENT DATE

Kevin Wejener 11.9.10
CITY ENGINEER DATE

SINGLE FAMILY LOT
EROSION CONTROL PLAN
TYPE C

11 OF 11



STANDARD

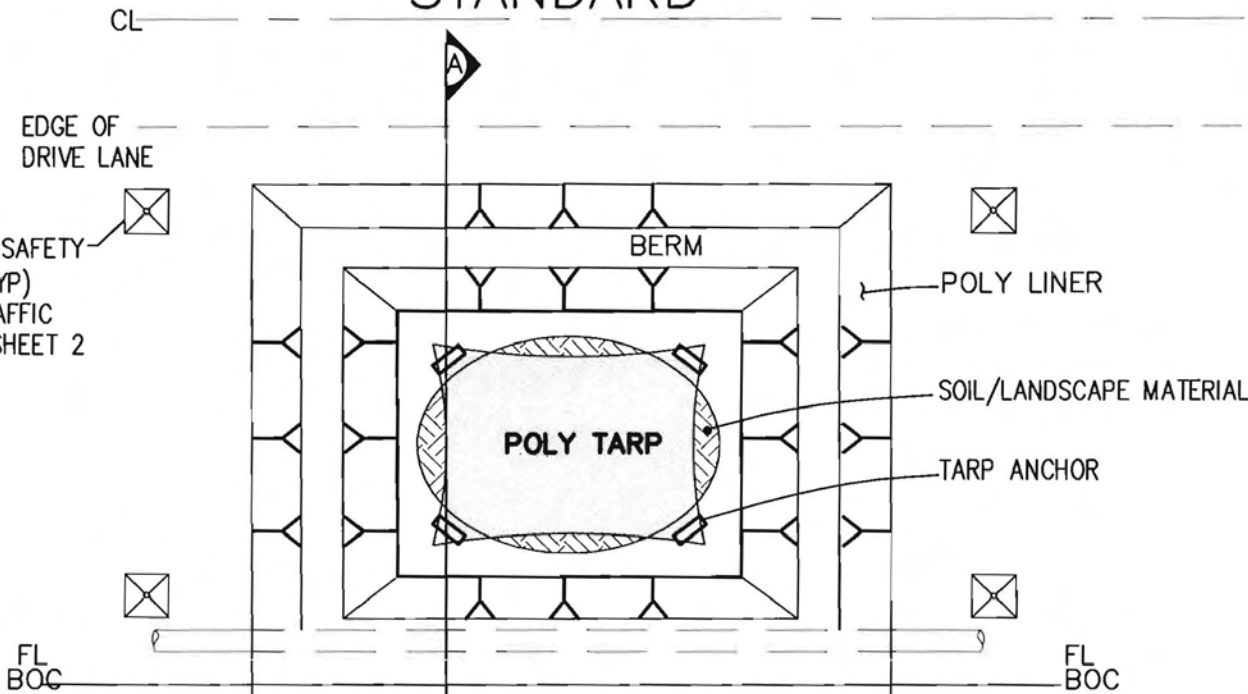

PLAN VIEW
NTS

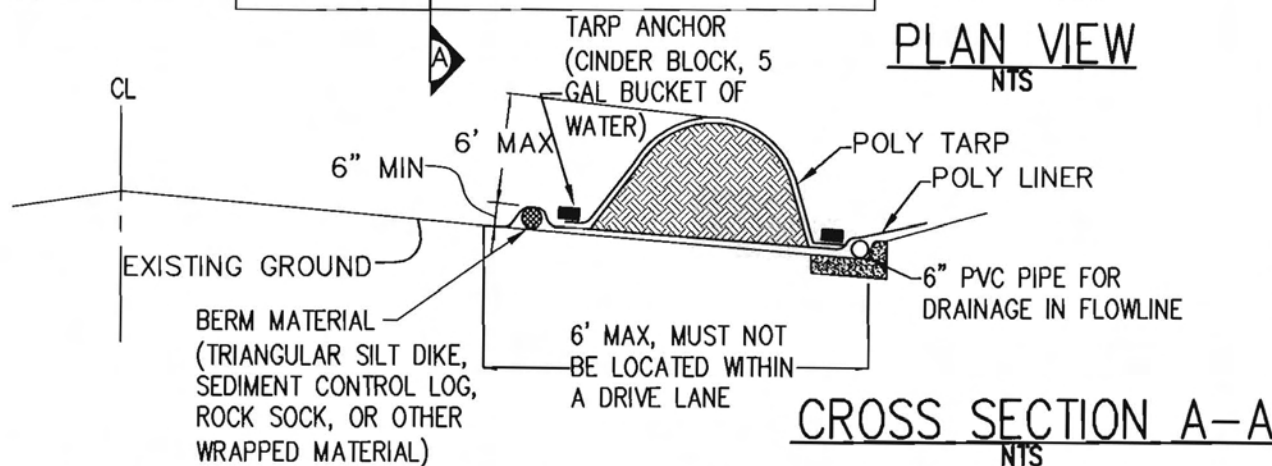

CROSS SECTION A-A
NTS

NOTES:

1. NOT FOR USE ON ARTERIAL ROADWAYS. FOR COLLECTOR STREETS, PUBLIC WORKS TRAFFIC DEPT. APPROVAL IS REQUIRED PRIOR TO PLACING MATERIALS IN THE ROADWAY.
2. FEATURE MUST BE CONSTRUCTED PRIOR TO EXCAVATION, EARTHWORK OR DELIVERY OF MATERIALS. FEATURE IS ALLOWED IN PARKING LANE ONLY.
3. MATERIALS MUST BE STATIONED ON THE POLY LINER. ANY INCIDENTAL MATERIALS DEPOSITED ON PAVED SECTION OR CURB FLOWLINE MUST BE CLEANED UP IMMEDIATELY.
4. FEATURE IS NOT INTENDED FOR USE WITH WET MATERIAL THAT WILL BE DRAINING AND/OR SPREADING OUT ON THE POLY LINER OR FOR DEMOLITION MATERIALS.
5. POLY LINER AND TARP COVER SHOULD BE OF SIGNIFICANT THICKNESS TO PREVENT DAMAGE OR LOSS OF INTEGRITY.
6. SAND BAGS MAY BE SUBSTITUTED TO ANCHOR THE COVER TARP OR PROVIDE BERMING UNDER THE BASE LINER.
7. THIS APPLICATION SHOULD BE USED:
 - FOR UTILITY REPAIRS
 - WHEN OTHER STAGING LOCATIONS ARE LIMITED
 - FOR OTHER LIMITED APPLICATIONS AND SHORT DURATION STAGING.
 - UNLESS ALTERNATIVE METHODS HAVE BEEN APPROVED ON THE SWMP OR BY WRITTEN CITY APPROVAL OF THE WATER DEPT. AND PUBLIC WORKS.

CITY OF AURORA, COLORADO
Chris [Signature] 1/15/10
 AURORA WATER DEPARTMENT DATE
Kevin [Signature] 1-15-10
 CITY ENGINEER DATE

**MATERIALS STAGING
IN ROADWAY**

1 OF 2

STANDARD

Materials Staging In Roadway - Control features are installed to provide containment and control for earthen, excavation, landscaping, and etc. materials on paved sections. These features should be used sparingly and for very short durations.

Traffic Issues

- Material staging in the travel lane of a street is NOT allowed. Staging in a legal parking lane is allowed (Collector streets require approval).
- Provide 4 MUTCD approved drums, tubular markers, or vertical panels to mark the outer boundaries of the feature.
- Construction requiring lane closures shall have an approved traffic plan, alternative BMP method approval, and is not covered under this detail. Contact the Public Works, Engineering Division 48 hours in advance.



Key Installation and Maintenance Requirements:

- These features should only be used when other options have been exhausted
- Integrity of feature(s) must be maintained to ensure adequate containment and function
- Locations where run-on may be encountered should be avoided
- It is the operators responsibility to ensure that the surrounding paved surfaces and curb flowlines are not impacted by the work or materials.

It is never acceptable to stage stockpiles or place earthen materials on paved sections or in curb flowlines without appropriate controls to contain the material and prevent migration.



CITY OF AURORA, COLORADO

Clay 2010 1/12/10
AURORA WATER DEPARTMENT DATE

Kevin Wegener 1.15.10
CITY ENGINEER DATE

MATERIALS STAGING
IN ROADWAY

2 OF 2



STANDARD

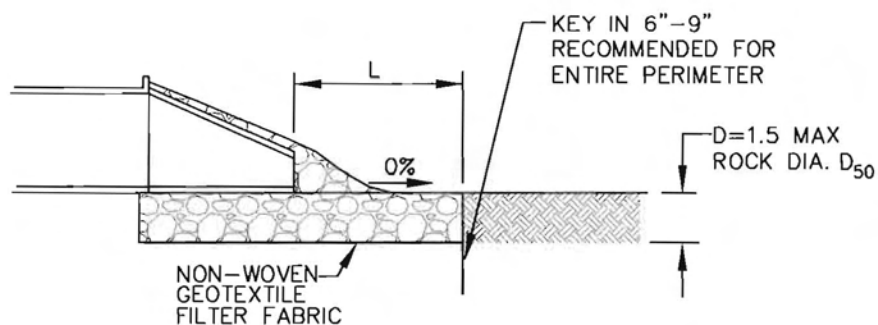
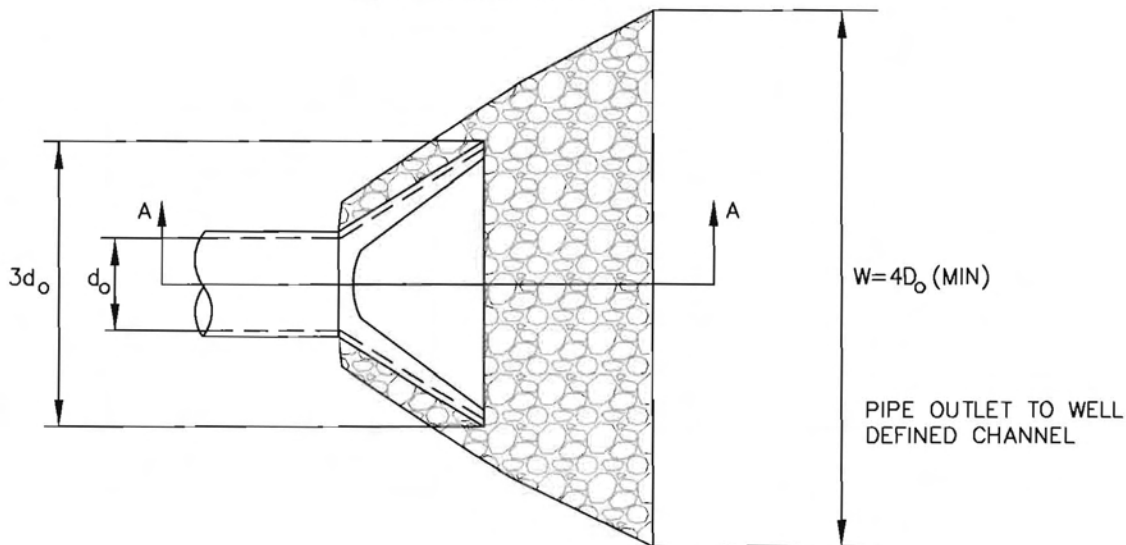
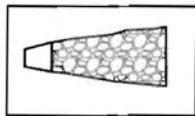

PIPE DIAMETER, D_o INCHES	DISCHARGE, Q CFS	APRON LENGTH, L FT	RIPRAP D_{50} DIAMETER MIN INCHES
8	2.5	5	4
	5	10	6
12	5	10	4
	10	13	6
18	10	10	6
	20	16	9
	30	23	12
24	40	26	18
	30	16	9
	40	26	9
	50	26	12
	60	30	18

NOTES:

1. OUTLET PIPE MUST BE AT 10% OR LESS.
2. TEMPORARY OUTLET PROTECTION INFORMATION IS FOR OUTLETS INTENDED TO BE UTILIZED LESS THAN 2 YEARS
3. FOR OUTLET PROTECTION THAT DOES NOT MEET THESE CRITERIA, DESIGN PER UDFCD, LATEST REVISION.
4. ENGINEER TO PROVIDE ALL DIMENSIONS ON PLANS FOR EACH OUTLET PROTECTION. A DESIGN TABLE MAY BE USED.

CITY OF AURORA, COLORADO

Clay D. [Signature] 1/24/10
AURORA WATER DEPARTMENT DATE

Kevin W. [Signature] 1.15.10
CITY ENGINEER DATE

TEMPORARY
OUTLET PROTECTION

1 OF 2



STANDARD

Outlet Protection - is installed to protect surfaces at pipe, culvert, drain, rundown and other discharge points from erosion and scour due to high and/or persistent flow velocities. Installed outlet protection functions as a flow control feature, reducing the velocity of concentrated flows and provide stabilized cover to prevent erosion. Installations may include riprap aprons or check dams.

Key Installation and Maintenance Requirements:

- Riprap aprons will be of an appropriate size, coverage and rock classification to maintain integrity and function to protect the immediate and adjoining areas at the discharge point.
- Recycled or demolished concrete material is not an acceptable substitute for rock
- Sediment accumulations need to be cleaned out to prevent re-suspension and conveyance downgradient



Features that are not adequately sized and installed for the outlet discharge volume can fail and cause property damage.

CITY OF AURORA, COLORADO

[Signature] 1/12/10
AURORA WATER DEPARTMENT DATE

[Signature] 1-15-10
CITY ENGINEER DATE

TEMPORARY
OUTLET PROTECTION

2 OF 2



STANDARD

ALTERNATIVE TO STEPS ON BANKS ABOVE CREST: DEFORM GABIONS AS NECESSARY TO ALIGN TOP OF GABIONS WITH GROUND SURFACE: AVOID GAPS BETWEEN GABIONS.

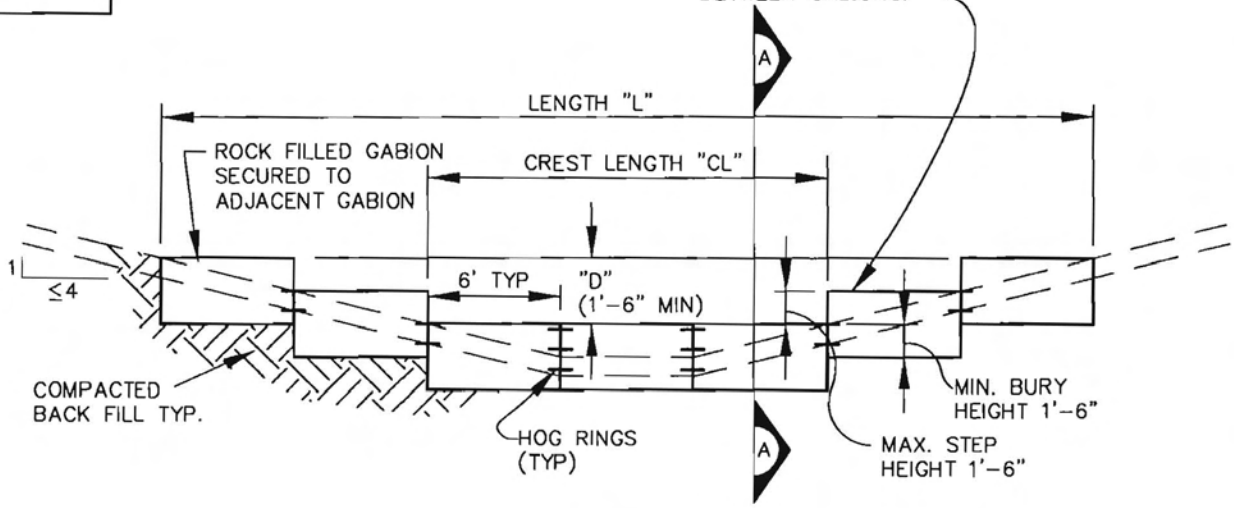

REINFORCED - ELEVATION

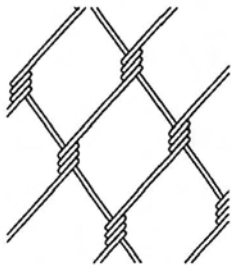

BLOW UP OF TWISTED WIRE GABION

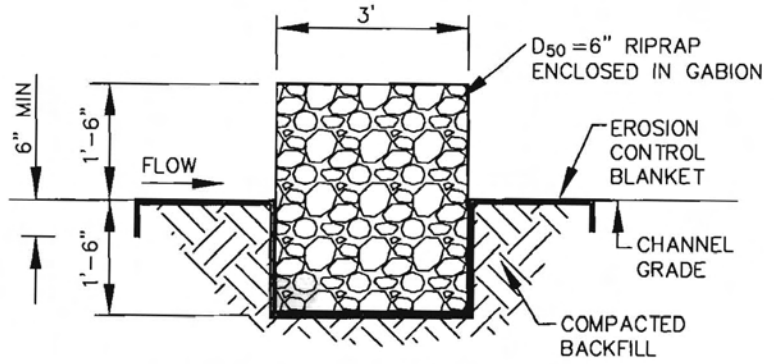

REINFORCED - SECTION

NOTES:

1. CHECK DAMS INDICATED ON PLAN SHALL BE INSTALLED AFTER CONSTRUCTION FENCE. BUT PRIOR TO ANY UPSTREAM LAND-DISTURBING ACTIVITIES.
2. REINFORCED CHECK DAMS, GABIONS SHALL HAVE GALVANIZED TWISTED WIRE NETTING WITH A MAXIMUM OPENING DIMENSION OF 4-1/2" AND MINIMUM WIRE THICKNESS OF 0.10". WIRE "HOG RINGS" AT 4" SPACING OR OTHER APPROVED MEANS SHALL BE USED AT ALL GABION SEAMS AND TO SECURE THE GABION TO THE ADJACENT GABION.
3. RIPRAP UTILIZED FOR CHECK DAMS SHALL HAVE A D₅₀ MEDIAN STONE SIZE OF 6".
4. THE CHECK DAM SHALL BE TRENCHED INTO THE GROUND A MINIMUM OF 1'-6".
5. EROSION BLANKET SHALL BE PLACED IN THE REINFORCED CHECK DAM TRENCH EXTENDING A MINIMUM OF 1'-6" ON BOTH THE UPSTREAM AND DOWNSTREAM SIDES OF THE REINFORCED CHECK DAM.
6. LENGTH, DEPTH AND CREST LENGTH SHALL BE PROVIDED ON PLANS.
7. USE OF RECYCLED CONCRETE IS NOT ACCEPTABLE.

SOURCE: ADAPTED FROM DOUGLAS COUNTY GESC STANDARD DETAILS

CITY OF AURORA, COLORADO

Joseph J. Wray 6-5-09
AURORA WATER DEPARTMENT DATE

Kevin W. Geiger 6-4-09
CITY ENGINEER DATE

REINFORCED CHECK DAM

1 OF 1



STANDARD

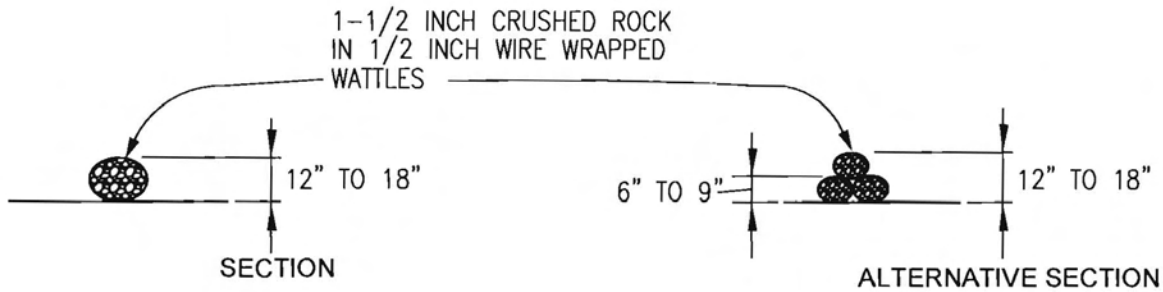
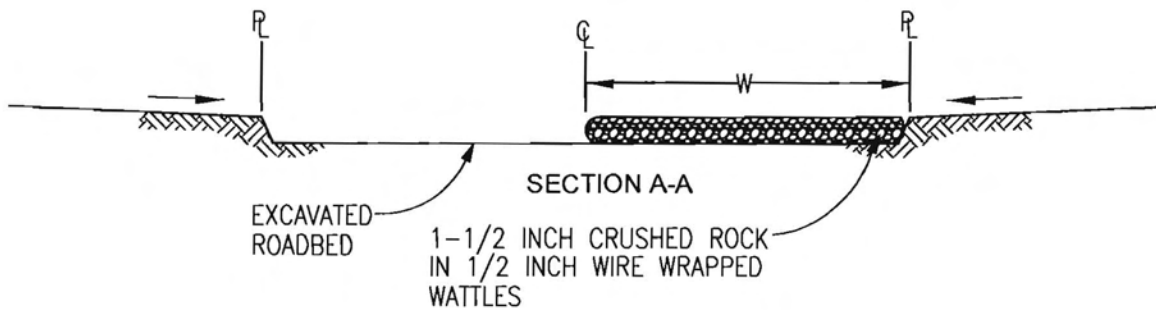
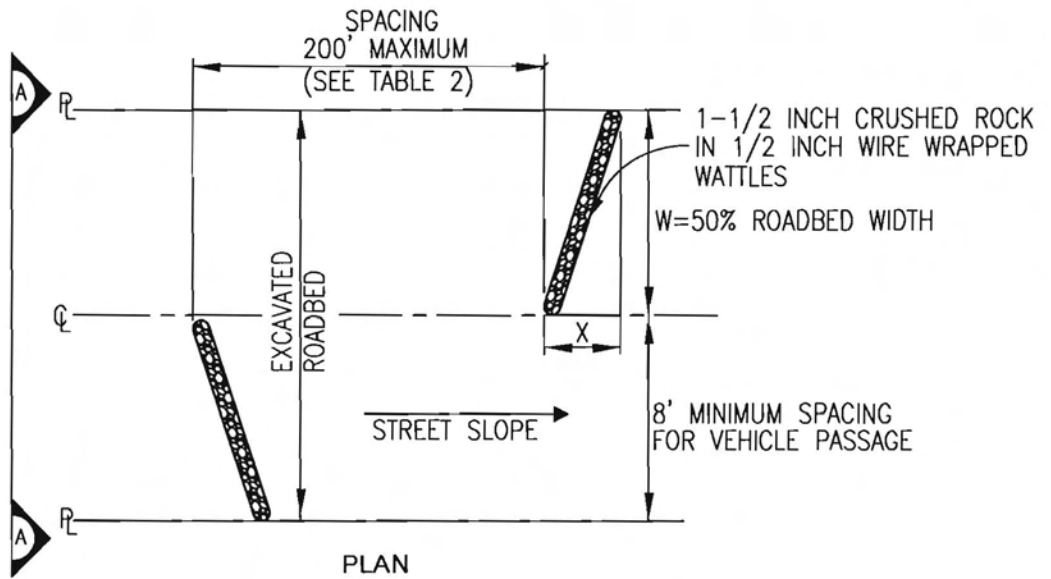
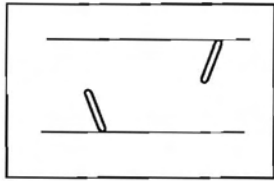

TABLE 1

W	X
20'-30'	5'
31'-40'	7'
41'-50'	9'
51'-60'	10.5'
61'-70'	12'

TABLE 2

STREET SLOPE	SPACING
<2%	NOT TYPICALLY NEEDED
2%	200 FT
3%	200 FT
4%	150 FT
5%	100 FT
6%	50 FT
7%	25 FT
8%	25 FT

CITY OF AURORA, COLORADO

Chris [Signature] 1/12/10
 AURORA WATER DEPARTMENT DATE

Kevin Wegener 1.15.10
 CITY ENGINEER DATE

ROUGH CUT
 STREET CONTROL

1 OF 2



STANDARD

Rough Cut Street Control - features are installed to prevent sheet flows from eroding temporary dirt roads or streets still under construction. Installing Rough Cut Street Control features will help to check the velocities of run-off and divert the flows from roadways under construction. These features are constructed of berms, placed along alternating sides of a roadway. They function to slow or capture street conveyed flows and divert them off the road. These features should be installed when a road is cut in, but will not be paved for 14-days or more.

Key Installation and Maintenance Requirements:

- Berms need to be adequately compacted
- Features need to be regroomed when integrity and function has been compromised.



Unpaved, temporary or haul roads can easily erode when no control features are installed.

CITY OF AURORA, COLORADO

[Signature] 1/12/10
AURORA WATER DEPARTMENT DATE
[Signature] 1-15-10
CITY ENGINEER DATE

ROUGH CUT
STREET CONTROL

2 OF 2



STANDARD

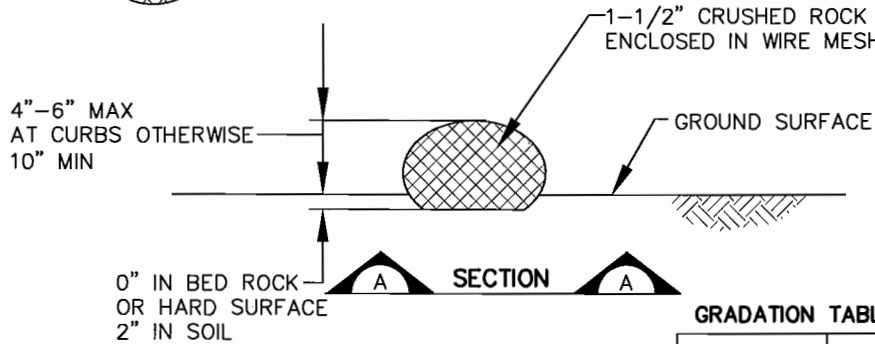
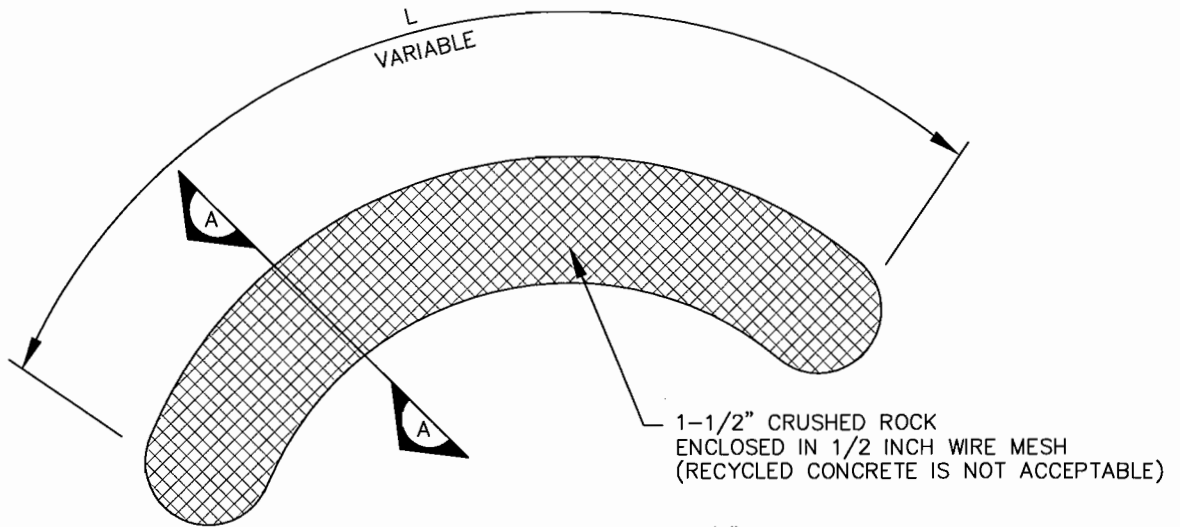
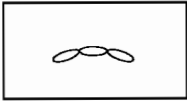

GRADATION TABLE

SIEVE SIZE	MASS PERCENT PASSING SQUARE MESH SIEVES
	NO. 4
2"	100
1 1/2"	90 - 100
1"	20 - 55
3/4"	0 - 15
3/8"	0 - 5

MATCHES SPECIFICATIONS FOR NO. 4 COARSE AGGREGATE FOR CONCRETE PER AASHTO M43. ALL ROCK SHALL BE FRACTURED FACE, ALL SIDES.

ANY GAP AT JOINT SHALL BE FILLED WITH 1-1/2" CRUSHED ROCK AND WRAPPED WITH ADDITIONAL WIRE MESH SECURED TO ENDS OF ROCK SOCK.

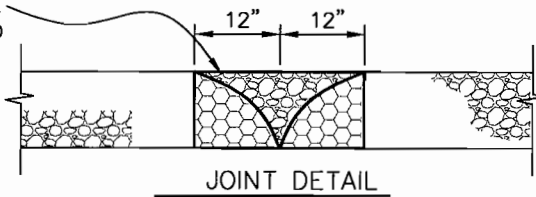

NOTES:

1. SEE PLAN VIEW FOR:
-LOCATIONS OF ROCK SOCKS
2. ROCK SOCK SECTION APPLIES TO CULVERT INLET FILTER AND INLET PROTECTION.
3. CRUSHED ROCK SHALL BE FRACTURED FACE (ALL SIDES) AND SHALL COMPLY WITH GRADATION SHOWN ON SHEET 1 (1-1/2" MINUS).
4. WIRE MESH SHALL BE FABRICATED OF 16-20 GAUGE WIRE TWISTED INTO A MESH WITH A MAXIMUM OPENING OF 1/2" INCH. ROLL WIDTH SHALL BE 48". 16-20 GAUGE CHICKEN WIRE MAY BE USED IF DOUBLE WRAPPED WITH NO MORE THAN 1/2" OPENINGS.
5. WIRE MESH SHALL BE SECURED USING "HOG RINGS" OR WIRE TIES AT 6" CENTERS ALONG ALL JOINTS AND AT 2" CENTERS ON ENDS OF SOCKS
6. FOR CONCENTRATED FLOW AREAS THE ENDS OF THE ROCK SOCKS SHALL BE 12" HIGHER THAN THE CENTER OF THE SOCK.
7. SEDIMENT ACCUMULATED UPSTREAM OF THE ROCK SOCK SHALL BE REMOVED WHEN THE SEDIMENT DEPTH UPSTREAM OF THE FILTER IS AT HALF THE HEIGHT OF THE BMP.

CITY OF AURORA, COLORADO

Chris Steen 11/5/10
AURORA WATER DEPARTMENT DATE

Kevin Wegener 11-9-10
CITY ENGINEER DATE

ROCK SOCKS/
WATTLES

1 OF 2



STANDARD

Rock Sock - also known as Rock Wattle, can be installed to function as a check dam, culvert protection, topside protection (at an inlet), inlet protection, curb sock.

Key Installation and Maintenance Requirements:

- Rock wattles should be constructed and maintained to diameter of 4" to 6" when used at curbs, but in other applications 10" minimum is required.
- Broken or damaged rock wattles require replacement or repairs
- Enclosures other than wire mesh are not allowed.



Installed features need to be appropriate for the application, sized and installed to function as intended, and maintained in good operating condition. This feature is clogged with sediment and can no longer adequately function to filter flows.



CITY OF AURORA, COLORADO

Chris [Signature] 1/15/10
AURORA WATER DEPARTMENT DATE
Hein [Signature] 1-15-10
CITY ENGINEER DATE

ROCK SOCKS/
WATTLES

2 OF 2



STANDARD

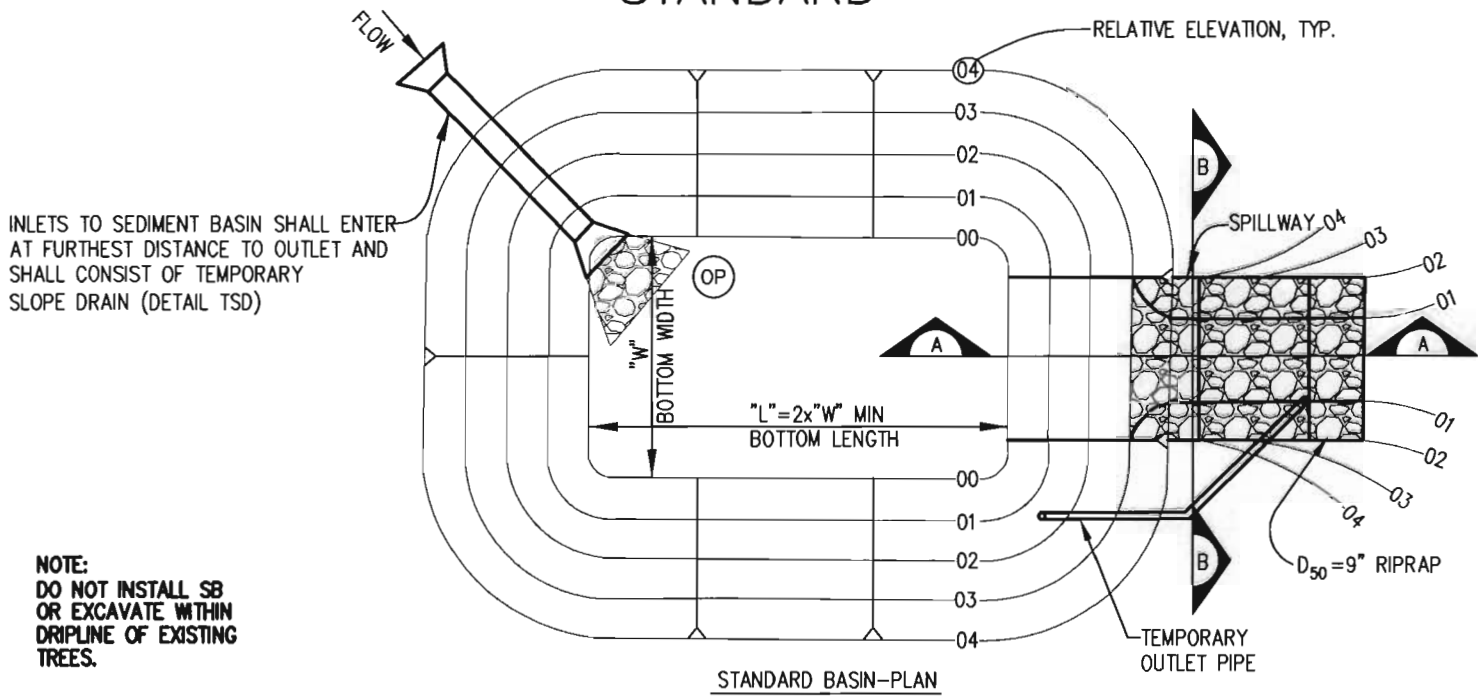

STANDARD BASIN-PLAN

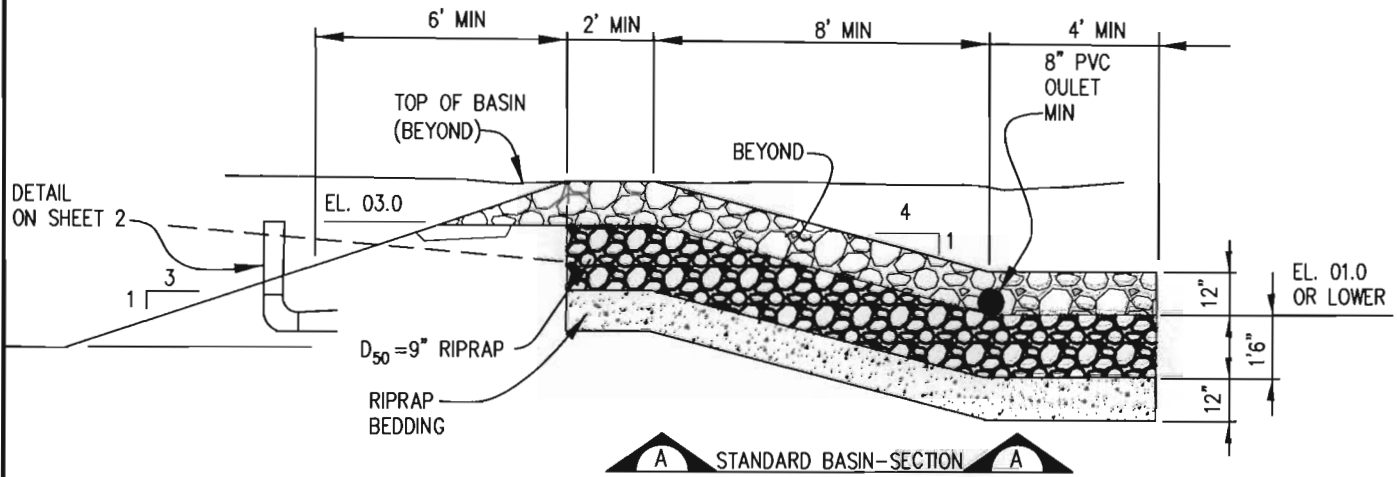

STANDARD BASIN-SECTION A

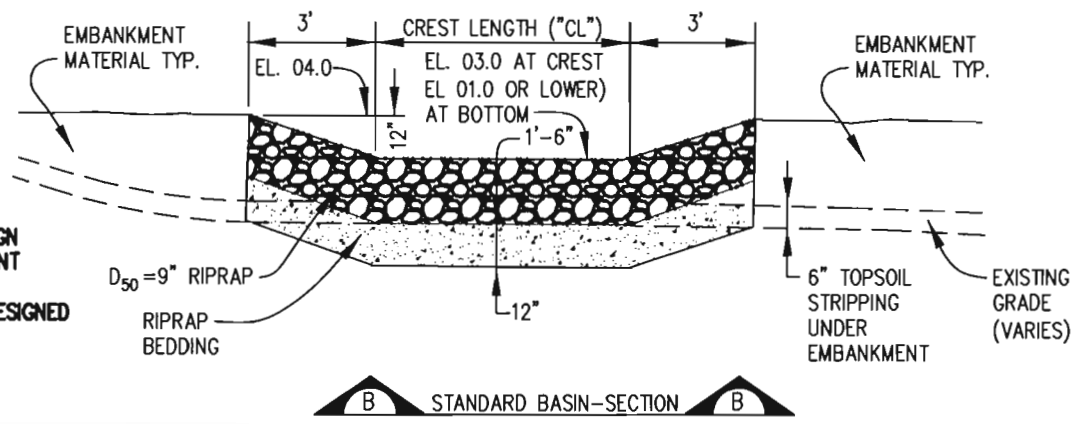

STANDARD BASIN-SECTION B

***THIS DETAIL IS A DESIGN GUIDELINE. ALL SEDIMENT BASINS ARE REQUIRED TO BE SPECIFICALLY DESIGNED FOR SITE CONDITIONS.**

SOURCE: ADAPTED FROM DOUGLAS COUNTY GESC STANDARD DETAILS

REQUIRED ON ALL DRAINAGE AREAS GREATER THAN 2 ACRES

CITY OF AURORA, COLORADO
Chris Zott 7/1/10
 AURORA WATER DEPARTMENT DATE
Jim Wegner 9-2-10
 CITY ENGINEER DATE

SEDIMENT
BASIN

1 OF 4

SB

STANDARD

NOTES:

1. SEE PLAN VIEW FOR:
-LOCATION OF SEDIMENT BASIN.
2. SEDIMENT BASINS INDICATED ON INITIAL PLAN SHALL BE INSTALLED PRIOR TO ANY OTHER LAND-DISTURBING ACTIVITY.
3. EMBANKMENT MATERIAL SHALL CONSIST OF SOIL FREE OF DEBRIS, ORGANIC MATERIAL, CONCRETE AND ROCKS GREATER THAN 3 INCHES AND SHALL HAVE A MINIMUM OF 15 PERCENT BY WEIGHT PASSING THE NO. 200 SIEVE.
4. EMBANKMENT MATERIAL SHALL BE COMPACTED TO AT LEAST 95 PERCENT OF MAXIMUM DENSITY WITHIN 2 PERCENTAGE POINTS OF OPTIMUM DENSITY IN ACCORDANCE WITH ASTM D898.
5. PIPE SCH 40 PVC OR GREATER SHALL BE USED.
6. NO HOLES ARE ALLOWED IN THE 90° BEND.
7. SEDIMENT BASINS SHALL BE DESIGNED IN ACCORDANCE WITH URBAN DRAINAGE AND FLOOD CONTROL DISTRICT'S STORM DRAINAGE CRITERIA MANUAL, VOLUME 3 UNLESS OTHERWISE SPECIFIED ON THESE DETAILS.

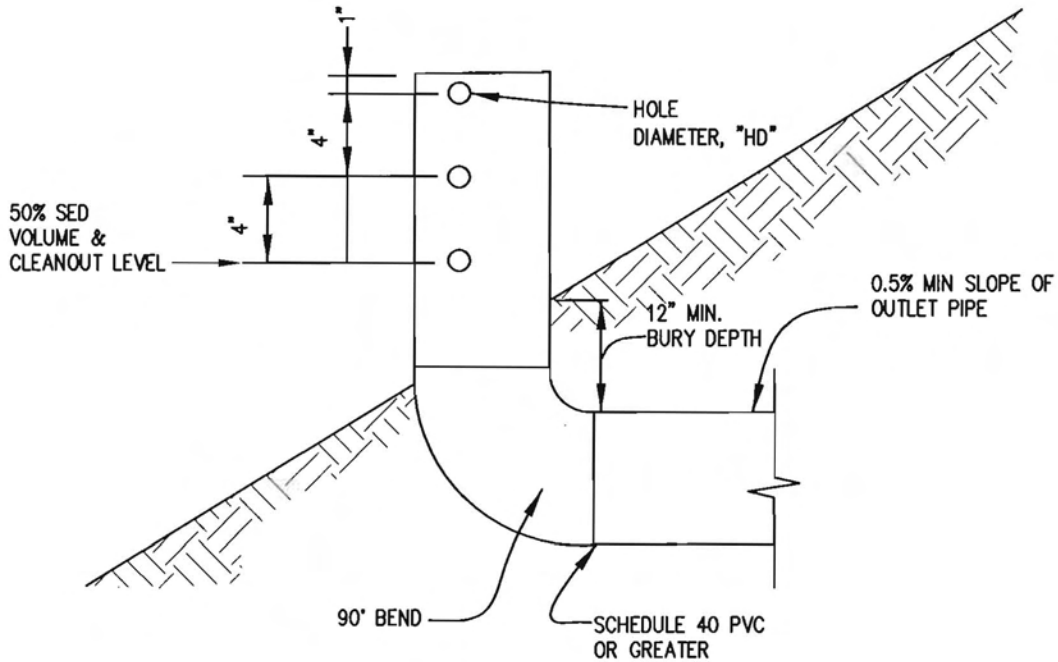

REQUIRED ON ALL DRAINAGE AREAS GREATER THAN 2 ACRES

CITY OF AURORA, COLORADO <i>Chad Stone</i> AURORA WATER DEPARTMENT DATE 1/12/10	SEDIMENT BASIN	2 OF 4 <div style="border: 1px solid black; border-radius: 50%; width: 40px; height: 40px; margin: 0 auto; display: flex; align-items: center; justify-content: center;"> SB </div>
<i>Kevin Wegener</i> CITY ENGINEER DATE 1-15-10		

STANDARD

FOR TRIBUTARY AREA > 15 ACRE
 -REQUIRED STORAGE VOLUME $V = 2,700$ CU-FT/AC
 -72-HOUR DRAIN TIME

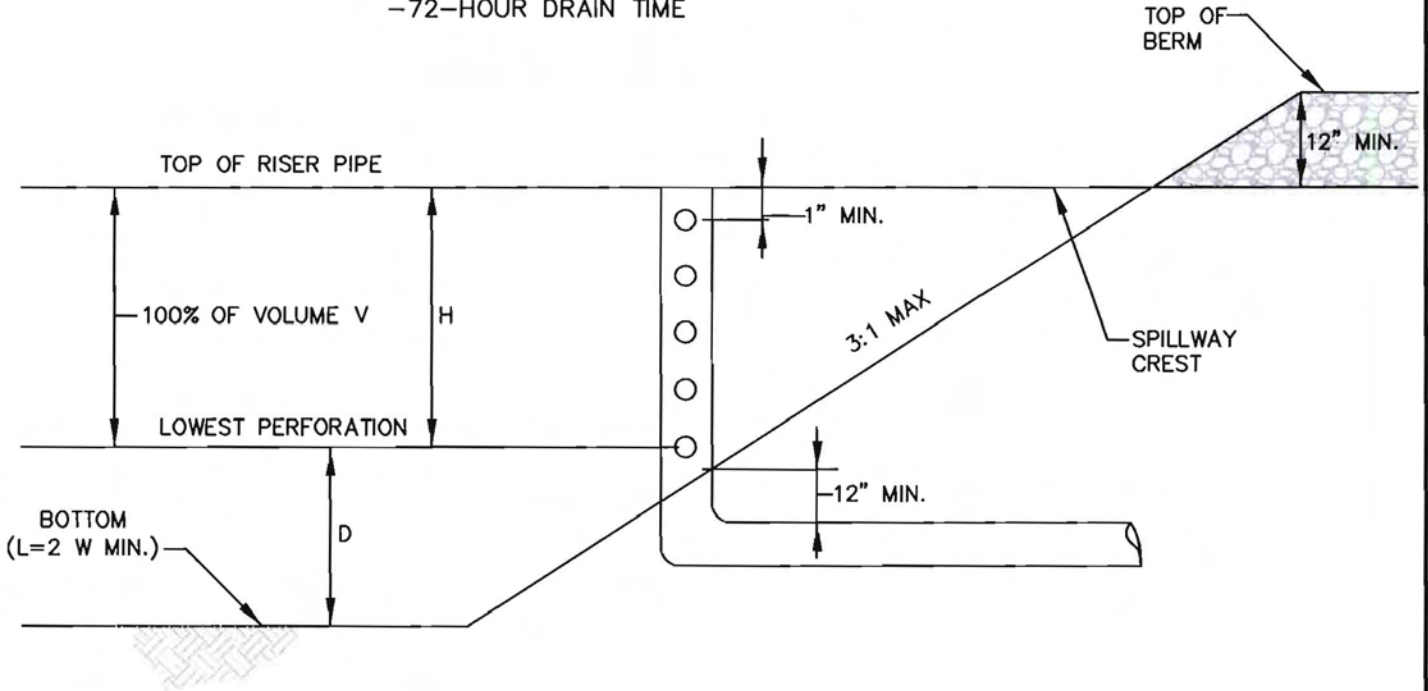

1. SUBSTITUTE V FOR "EURV" AND H FOR "H" IN EQUATION SQ-13A (PAGE SO-12, STORAGE CHAPTER UDFCD VOL. 2) TO DETERMINE "REQUIRED AREA PER ROW".
2. HOLES ARE LOCATED 4" ON CENTERS.
3. "D" CORRESPONDS TO $1/3 V$ OR 2.5' MINIMUM. REMOVE SEDIMENT WHEN SEDIMENT DEPTH IS 6" BELOW LOWEST PERFORATION.
4. SEDIMENT BASINS SHALL BE DESIGNED IN ACCORDANCE WITH URBAN DRAINAGE AND FLOOD CONTROL DISTRICT'S STORM DRAINAGE CRITERIA MANUAL, VOLUME 3 UNLESS OTHERWISE SPECIFIED ON THESE DETAILS.

CITY OF AURORA, COLORADO
[Signature] 1/12/10
 AURORA WATER DEPARTMENT DATE
[Signature] 1-15-10
 CITY ENGINEER DATE

TEMPORARY
 SEDIMENT BASIN

3 OF 4

SB

STANDARD

Sediment Basin - used as a run-off detention facility that captures sediment-laden runoff and release it slowly, providing detention time to facilitate the settling of soil and suspended particles.

Key Installation and Maintenance Requirements:

- Shall include an armored, emergency spillway feature (weir). Recycled concrete is not acceptable.
- A riprap apron shall be provided around the pipe outlet in conformance with the Outlet Protection detail.
- Sediment accumulated within the sediment basin should be removed when the sediment depth is 1 foot deep.
- After larger storm events the spillway shall be inspected for damage and repaired as needed.



Sediment Basins that are not installed correctly and/or not maintained are subject to embankment failure and by-pass.

CITY OF AURORA, COLORADO

Chris [Signature]
AURORA WATER DEPARTMENT

1/15/10
DATE

Kevin Wegener
CITY ENGINEER

1-15-10
DATE

SEDIMENT
BASIN

4 OF 4



STANDARD

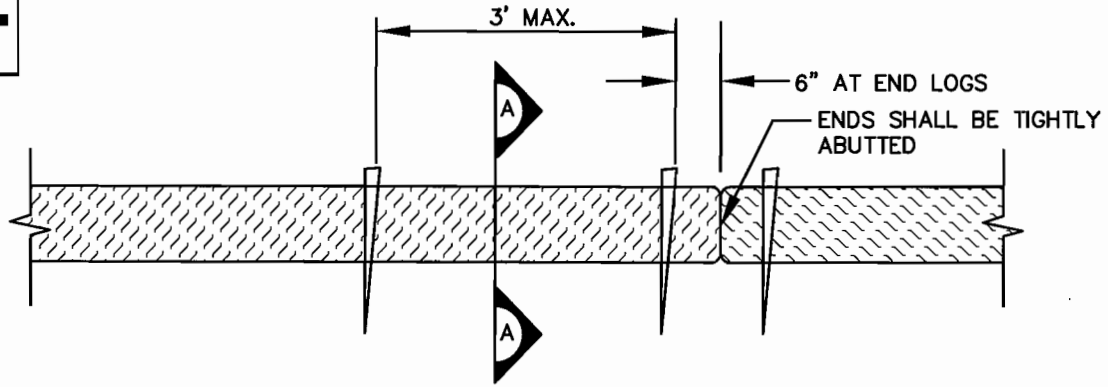
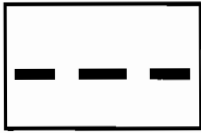

DETAIL

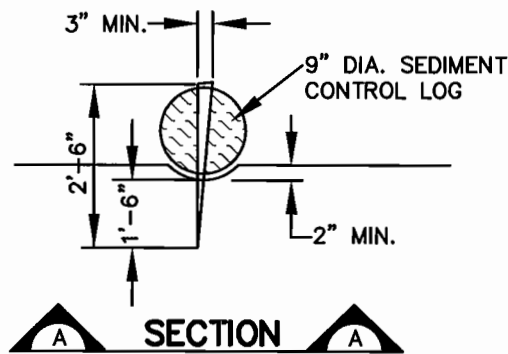

SECTION

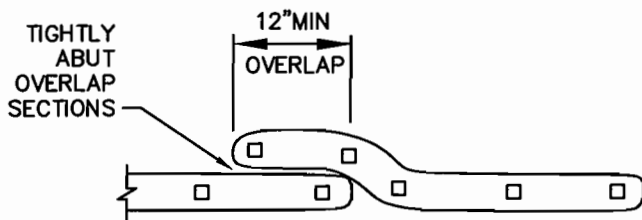

OVERLAP ALTERNATIVE JOINT DETAIL

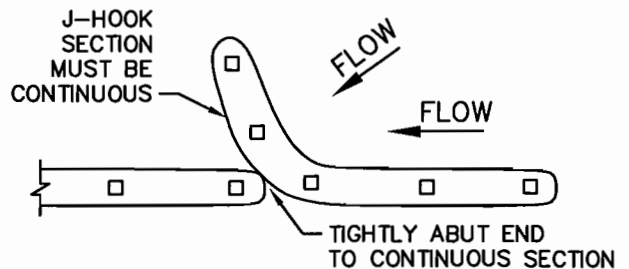

J-HOOK ALTERNATIVE JOINT DETAIL

NOTES:

1. SEE PLAN VIEW FOR LOCATION OF SEDIMENT CONTROL LOG.
2. SEDIMENT CONTROL LOGS SHALL CONSIST OF STRAW, EXCELSIOR, OR COCONUT FIBER.
3. NOT FOR USE IN CONCENTRATED FLOW AREAS.
4. THE SEDIMENT CONTROL LOG SHALL BE TRENCHED INTO THE GROUND A MINIMUM OF 2" AND SECURED TO THE GROUND.
5. 12" DIAMETER SEDIMENT CONTROL LOGS ARE REQUIRED IN AREAS WHERE THE SLOPE UPSTREAM OF THE LOG IS GREATER THAN 10%.

SOURCE: ADAPTED FROM
DOUGLAS COUNTY GESC
STANDARD DETAILS

CITY OF AURORA, COLORADO

Chris J. Stue 11/5/10
AURORA WATER DEPARTMENT DATE
Alan Wegener 11-9-10
CITY ENGINEER DATE

SEDIMENT CONTROL LOG

1 OF 2



STANDARD

Sediment Control Log – is a wattle with excelsior, straw, or coconut fill material constructed to create a pervious filter, able to facilitate overtopping. The log promotes sediment removal on the upgradient side and a reduction in flow velocities. Can be used for perimeter control, as a sediment barrier and as a slope break

Key Installation and Maintenance Requirements:

- The erosion control log should be trenched into the ground a minimum of 2 inches and staked or stapled through the feature and into the ground
- Sediment accumulated upstream of wattles should be removed when the sediment depth upgradient of the wattle is within 1/2 of the height of the crest or when debris accumulation compromises the effectiveness of the feature.



Sediment Control Logs are not appropriate in concentrated flow applications. They are easily overwhelmed, as depicted with this example.

CITY OF AURORA, COLORADO
Chris [Signature] 1/12/10
AURORA WATER DEPARTMENT DATE
Kevin Wegener 1-15-10
CITY ENGINEER DATE

SEDIMENT CONTROL LOG

2 OF 2



STANDARD

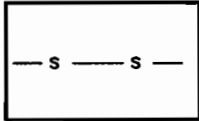

SOURCE: ADAPTED FROM DOUGLAS COUNTY GESC STANDARD DETAILS

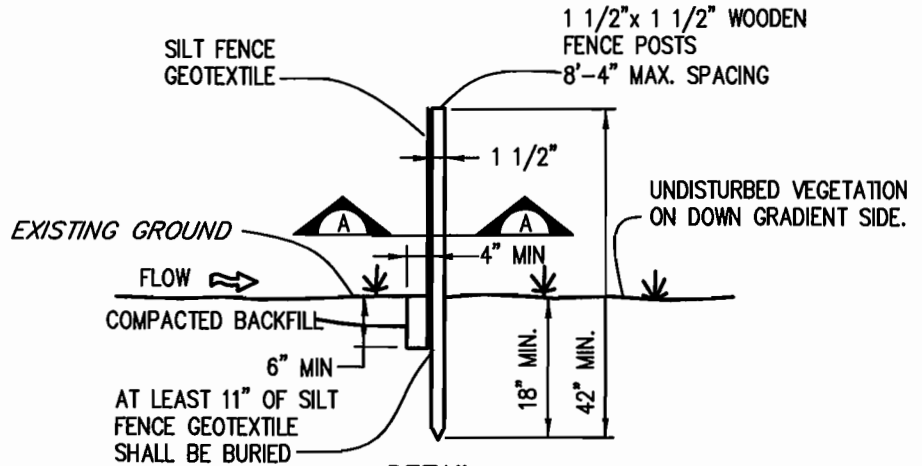

DETAIL
SCALE: 1/2" = 1'-0"

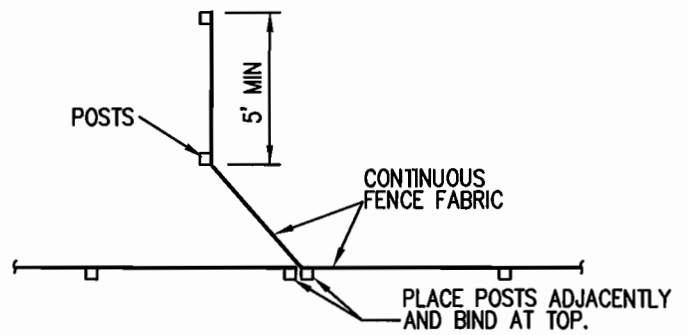
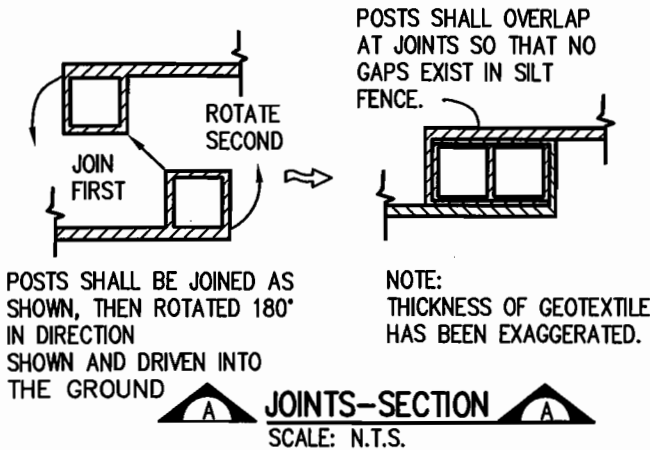

J-HOOK DETAIL
SCALE: NTS

SILT FENCE GEOTEXTILE SHALL MEET THE MANDATORY REQUIREMENTS LISTED BELOW

PROPERTIES	TEST METHOD	MANDATORY REQUIREMENTS
GRAB TENSILE STRENGTH	ASTM D 4632	≥124 LBS
MULLEN BURST STRENGTH	ASTM D 3786	≥300 PSI
PUNCTURE STRENGTH	ASTM D 4833	≥60 LBS
TRAPEZOID TEAR STRENGTH	ASTM D 4533	≥65 LBS
UV RESISTANCE	ASTM D 4355	≥80% AT 500 HOURS OF UV EXPOSURE
FLOW RATE	ASTM D 4491	≥10 GAL/MIN/FT ²
MINIMUM TENSILE STRENGTH		0.45 kN

NOTES:

- SILT FENCE MUST BE PLACED AWAY FROM TOE OF SLOPE TO ALLOW FOR WATER PONDING.
- SILT FENCE MAY BE USED ALONG PERIMETERS SO LONG AS SLOPES DO NOT EXCEED 5%. IF SLOPE IS GREATER THAN 5%, THEN SILT FENCE MAY BE INSTALLED ALONG THE CONTOUR OR A DIVERSION DIKE MAY BE REQUIRED.
- ANCHOR TRENCH SHALL BE EXCAVATED WITH TRENCHER, OR WITH SILT FENCE INSTALLATION MACHINE: NO ROAD GRADERS, BACKHOES, ETC. SHALL BE USED. TRENCH SHALL BE COMPACTED BY HAND WITH "JUMPING JACK", OR BY WHEEL ROLLING. COMPACTION SHALL BE SUCH THAT SILT FENCE RESISTS BEING PULLED OUT OF ANCHOR TRENCH BY HAND.
- SILT FENCE INDICATED ON PLAN SHALL BE INSTALLED PRIOR TO ANY LAND-DISTURBING ACTIVITIES UNLESS NOTED OTHERWISE.
- SEDIMENT ACCUMULATED UPSTREAM OF SILT FENCE SHALL BE REMOVED WHEN THE UPSTREAM SEDIMENT REACHES A DEPTH OF 6-INCHES.
- ADDITIONAL STAKES MAY BE PLACED ON THE FRONT SIDE OF THE SILT FENCE FOR ADDED STABILITY.
- DO NOT INSTALL WITHIN DRIPLINE OF EXISTING TREES.

CITY OF AURORA, COLORADO

Clyde Ste... 11/6/10
AURORA WATER DEPARTMENT DATE

Kevin Wegener 11.9.10
CITY ENGINEER DATE

SILT FENCE

1 OF 3



STANDARD

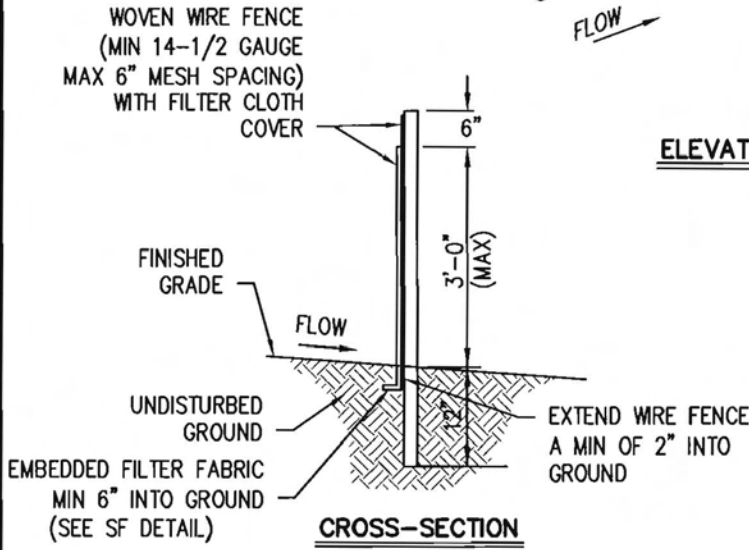
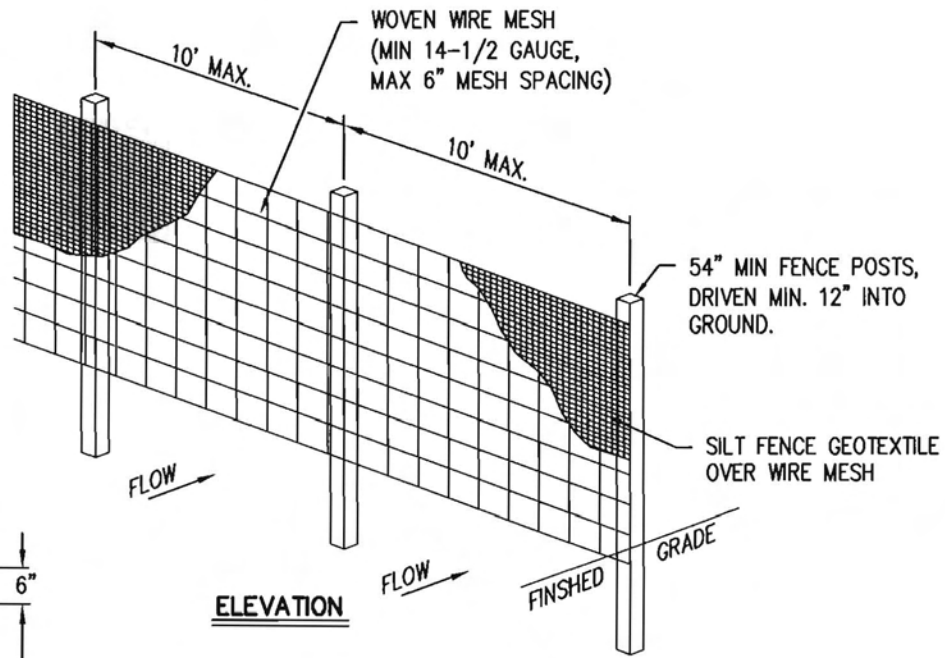
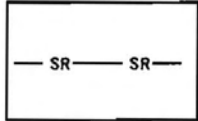

POSTS: STEEL EITHER "T" OR "U" TYPE
 FENCE: WOVEN WIRE, 14-1/2 GA.
 6" MAX MESH OPENINGS.
 FILTER: SILT FENCE GEOTEXTILE

NOTES:

1. SILT FENCE MUST BE PLACED AWAY FROM TOE OF SLOPE TO ALLOW FOR WATER PONDING.
2. SILT FENCE MAY BE USED ALONG PERIMETERS SO LONG AS SLOPES DO NOT EXCEED 5%. IF SLOPE IS GREATER THAN 5%, THEN SILT FENCE MAY BE INSTALLED ALONG THE CONTOUR OR A DIVERSION DIKE MAY BE REQUIRED.
3. ANCHOR TRENCH SHALL BE EXCAVATED WITH TRENCHER, OR WITH SILT FENCE INSTALLATION MACHINE: NO ROAD GRADERS, BACKHOES, ETC. SHALL BE USED. TRENCH SHALL BE COMPACTED BY HAND WITH "JUMPING JACK", OR BY WHEEL ROLLING. COMPACTION SHALL BE SUCH THAT SILT FENCE RESISTS BEING PULLED OUT OF ANCHOR TRENCH BY HAND.
4. SILT FENCE INDICATED ON PLAN SHALL BE INSTALLED PRIOR TO ANY LAND-DISTRUBING ACTIVITIES UNLESS NOTED OTHERWISE.
5. SEDIMENT ACCUMULATED UPSTREAM OF SILT FENCE SHALL BE REMOVED WHEN THE UPSTREAM SEDIMENT REACHES A DEPTH OF 6-INCHES.
6. ADDITIONAL STAKES MAY BE PLACED ON THE FRONT SIDE OF THE SILT FENCE FOR ADDED STABILITY.
7. WOVEN WIRE FENCE TO BE FASTENED SECURELY TO FENCE POSTS WITH WIRE TIES.
8. SILT FENCE TO BE FASTENED SECURELY TO WOVEN WIRE FENCE WITH TIES EVERY 24" AT TOP AND MID SECTION.
9. SEE SF DETAIL 1 OF 3 FOR WHEN TWO SECTIONS OF SILT FENCE ADJOIN EACH OTHER.

CITY OF AURORA, COLORADO
Chris 2 Co 1/15/10
 AURORA WATER DEPARTMENT DATE
Kevin Wegener 1.15.10
 CITY ENGINEER DATE

SILT FENCE—
 REINFORCED

2 OF 3



STANDARD

Silt Fence - is a temporary sediment barrier constructed of woven fabric stretched across and secured to supporting posts. The bottom edge of the fabric is buried and secured in an anchor trench that is backfilled with soil and compacted.

Key Installation and Maintenance Requirements:

- The bottom portion of the silt fence should be adequately trenched in and compacted so that silt-fencing filter fabric is buried and cannot be easily pulled out by hand. Silt fence installation machines that use trenching or slicing may be utilized to install silt fence
- When joints are necessary, filter cloth should be spliced together only at support posts and securely sealed
- Holes and other areas of compromise shall be promptly repaired, or sections replaced to maintain integrity of installed features
- Additional posts may be added if necessary. Steel or larger posts may be substituted
- Silt fences shall be removed when they have served their useful purpose. The area impacted by the installation and removal of the silt fence shall be stabilized after removal of the fencing.



J-Hooks should be added in applications when the fencing cannot be installed along the contour of the grade.

Silt Fencing has limited applications and its use should be avoided in locations where concentrated flows exist. Features cannot function as intended if they are not appropriate for the location, not installed correctly and/or are not maintained in a continuously good operating condition. Failures, such as this, can lead to off-site releases of sediment.



CITY OF AURORA, COLORADO
Chris 2/10 1/12/10
AURORA WATER DEPARTMENT DATE
Kevin Wegman 1.15.10
CITY ENGINEER DATE

SILT FENCE

3 OF 3



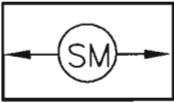

Final soil stabilization shall be the final ground cover defined by the site plan or associated documents. Temporary soil stabilization shall include grasses from seed and mulching as described below:

The seedbed shall be well settled and firm, but friable enough that seed can be placed at the seeding depth specified. The seedbed shall be reasonably free of weeds. Soils that have been over-compacted by traffic or equipment, especially when wet, shall be tilled or ripped to breakup rooting restrictive layers and then harrowed, rolled or packed to prepare the required firm seedbed. Mulch shall be applied at a rate of 2 ½ tons per acre and shall be attached by an approved method suitable for the type of mulch used. Mulch shall be spread uniformly, in a continuous blanket, after seeding is complete. Mulch shall be clean, weed and seed free, long stemmed straw of oats, wheat or rye. At least 50% of mulch, by weight, shall be ten inches or longer. Mulch shall be spread by hand or blower-type mulch spreader. Mulching shall be started on the windward side of relatively flat areas or on the upper part of a steep slope and continued uniformly until the area is covered. The mulch shall not be bunched. Immediately following spreading, the mulch shall be anchored to the soil by a v-type wheel land packer or a scalloped-disk land packer designed to force mulch into the soil surface a minimum of 3 inches. It is the contractor's responsibility to adjust the weights used by the equipment in order to achieve the required crimping depth. All seeded areas shall be mulched after seeding on the same day as the seeding. The type of a seed mix used will depend upon the following factors: temporary vs. permanent revegetation; time of year; soil type and slope. As a general rule, temporary revegetation will utilize annual grasses while permanent revegetation should utilize perennial grasses. The seed mix and rate of application shall be as follows:

Minimum Drill Seeding Rates for Annual Grasses

Species (Common Name)	Growth Season	Pounds of Pure Live Seed (PLS)/acre	Planting Depth (inches)
1. Oats	Cool	35-50	1-2
2. Spring Wheat	Cool	25-35	1-2
3. Spring Barley	Cool	25-35	1-2
4. Annual ryegrass	Cool	10-15	½
5. Millet	Warm	3-15	½-¾
6. Sudangrass	Warm	5-10	½-¾
7. Sorghum	Warm	5-10	½-¾
8. Winter Wheat	Cool	20-35	1-2
9. Winter Barley	Cool	20-35	1-2
10. Winter Rye	Cool	20-35	1-2
11. Triticale	Cool	25-40	1-2

NOTE:
HAND BROADCASTING MAY BE
REQUESTED BY VARIANCE, BUT
SEED RATES MUST BE
DOUBLED.

CITY OF AURORA, COLORADO

Chris J. [Signature] 9/1/10
AURORA WATER DEPARTMENT DATE
Kevin Wagner 9-2-10
CITY ENGINEER DATE

SEEDING & MULCHING

1 OF 7



STANDARD



Minimum Drill Seeding Rates for Perennial Grasses

Alkali Soil Seed Mix

Common Name	Botanical Name	Growth Season	Growth Form	Seeds/ Pound	Pounds of PLS/acre
Alkali sacaton	<i>Sporobolus airoides</i>	Warm	Bunch	1,750,000	2.0
Blue grama	<i>Bouteloua gracilis</i> 'Hachita'	Warm	Sod-forming bunchgrass	825,000	3.0
Akali grass	<i>Puccinella distans</i>	Cool	Sod	1,200,000	1.0
Sideoats grama	<i>Bouteloua curtipendula</i> 'Butte'	Warm	Sod	191,000	2.0
Sodar streambank wheatgrass	<i>Agropyron riparium</i>	Cool	Sod	170,000	1.0
Inland Saltgrass	<i>Distichlis stricta</i>	Warm	Sod	613,200	5.0
Arriba western wheatgrass	<i>Agropyron smithii</i>	Cool	Sod	110,000	6.0
Buffalograss	<i>Dactyloides</i> 'Sharp's Improved'	Warm	Sod	52,000	10.0
Total					30.0

Sandy Soil Seed Mix

Common Name	Botanical Name	Growth Season	Growth Form	Seeds/ Pound	Pounds of PLS/acre
Blue grama	<i>Bouteloua gracilis</i> 'Hachita'	Warm	Sod-forming bunchgrass	825,000	4.0
Little bluestem	<i>Schizachyrium scoparium</i> 'Pastura'	Warm	Bunch	240,000	3
Prairie sandreed	<i>Calamovilfa longifolia</i>	Warm	Open sod	274,000	3
Sand dropseed	<i>Sporobolus cryptandrus</i>	Warm	Bunch	5,298,000	2
Sideoats grama	<i>Bouteloua curtipendula</i> 'Butte'	Warm	Sod	191,000	3
Western wheatgrass	<i>Agropyron smithii</i> "Arriba"	Cool	Sod	110,000	4.0
Sand Bluestem	<i>Andropogon hallii</i> 'Garden'	Warm	Sod	113,300	2.0
Switchgrass	<i>Panicum virgatum</i>	Warm	Sod	389,000	6.0
Indian Ricegrass	<i>Oryzopsis hymenoides</i>	Cool	Bunch	141,000	4.0
Total					31.0

CITY OF AURORA, COLORADO

Chris S. St. 9/1/10
 AURORA WATER DEPARTMENT DATE
Kevin W. Jensen 9-2-10
 CITY ENGINEER DATE

SEEDING & MULCHING

2 OF 7



STANDARD

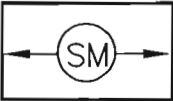

Sandy Loam to Clay Loam Soil Seed Mix					
Common Name	Botanical Name	Growth Season	Growth Form	Seeds/Pound	Pounds of PLS/acre
Blue Grama	<i>Bouteloua gracilis</i> 'Hachita'	Warm	Sod-forming bunch grass	825,000	4.0
Buffalograss	<i>Dactyloides</i> "Sharps Improved"	Warm	Sod	52,000	4.0
Sideoats grama	<i>Bouteloua curtipendula</i> 'Butte'	Warm	Sod	191,000	6.0
Sand dropseed	<i>Sporobolus cryptandrus</i> "Native"	Warm	Bunch	5,298,000	1.0
Western wheatgrass	<i>Agropyron smithii</i> "Arriba"	Cool	Sod	110,000	7.0
Junegrass	<i>Koeleria cristata</i>	Cool	Bunch	2,315,400	1.0
Little Bluestem	<i>Schizachyrium Scoparium</i> 'Blaze'	Warm	Bunch	260,000	2.0
Green Needlegrass	<i>Stipa Viridula</i> 'Lodorn'	Cool	Bunch	181,000	5.0
Total					30

CITY OF AURORA, COLORADO

Chris 2 str 9/1/10
 AURORA WATER DEPARTMENT DATE
Kevin Wegner 9-2-10
 CITY ENGINEER DATE

SEEDING & MULCHING

3 OF 7



STANDARD

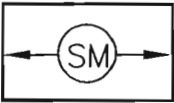

Damp or low areas, Ditches, Detention Ponds

Common Name	Botanical Name	Growth Season	Growth Form	Seeds/Pound	Pounds of PLS/acre
Buffalograss	<i>Buchloe dactyloides</i>	Warm	Sod	52,000	2.0
Blue grama	<i>Bouteloua gracilis</i> (<i>Chondrosium gracilis</i>) 'Hachita'	Warm	Sod-forming bunch grass	825,000	3.0
Switchgrass	<i>Panicum virgatum</i> 'Blackwell'	Warm	Sod	389,000	6.0
Western Wheatgrass	<i>Pascopyrum smithii</i>	Cool	Sod	110,000	6.0
Sand dropseed	<i>Sporobolus cryptandrus</i>	Warm	Bunch	5,298,000	1.0
Inland saltgrass	<i>Distichlis stricta</i>	Warm	Sod	613,200	3.0
Prairie cordgrass	<i>Spartina pectinata</i>	Warm	Sod	183,000	1.0
Little Bluestem	<i>Schizachyrium scoparium</i> 'Blaze'	Warm	Bunch	260,000	2.0
Sideoats Grama	<i>Bouteloua curtipendula</i>	Warm	Sod	191,000	3.0
Green Needlegrass	<i>Stipa viridula</i> 'Lodorn'	Cool	Bunch	181,000	1.0
Big Bluestem	<i>Andropogon gerardi</i> 'Pawnee'	Warm	Bunch	144,240	1.0
Yellow Indiangrass	<i>Sorghastrum nutans</i> 'Holt'	Warm	Bunch	174,720	1.0

Total 30.0

Where there is persistent water, add the following:

Wooly sedge	<i>Carex lanuginose</i>			322,340	4 ounces
Nebraska sedge	<i>Carex nebrascensis</i>			534,100	8 ounces
Baltic rush	<i>Juncus balticus</i>			12,300,000	4 ounces
Aster	<i>Aster laevis</i>			1,216,000	3 ounces
Showy milkweed	<i>Asclepias speciosa</i>			58,112	5 ounces
Wild Bergamot	<i>Monarda fistulosa</i>			1,400,136	3 ounces
Yarrow	<i>Achillea millefolium</i>			2,770,000	1 ounces
Subtotal					28 ounces/acres

Total 31.75 pls lbs/acre

Annual Grasses Perennial Grasses

Seeding Dates	Warm	Cool	Warm	Cool
January 1-March 15				
March 16-April 30	4	1, 2, 3		
May 1-May 15	4			
May 16-June 30	4, 5, 6, 7			
July 1-July 15	5, 6, 7			
July 16-August 31				
September 1-September 30		8, 9, 10, 11		
October 1-December 31		8		

CITY OF AURORA, COLORADO

Chris J. Ste... 9/1/10
 AURORA WATER DEPARTMENT DATE
Kevin W. Geyer 9-2-10
 CITY ENGINEER DATE

SEEDING & MULCHING

4 OF 7



STANDARD

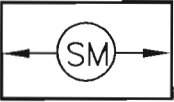

Number codes for annual species refer to specific seeding periods for: (1) oats; (2) Spring wheat; (3) spring barley; (4) annual ryegrass; (5) millet; (6) sundangrass; (7) sorghum; (8) winter wheat; (9) winter barley; (10) winter rye; and (11) triticale.

To provide temporary erosion control between the seeding dates specified, utilize surface roughening (on the contour or perpendicular to prevailing winds) and/or apply a mulch.

The seeding dates for perennial species are generally in the spring from March through early May, and in the fall after mid-October until snow cover or frozen soil precludes planting. Fall seeding is referred to as "dormant seeding" because the seeds will lie dormant through the winter and germinate in the spring. When "dormant seeding", add a nurse crop to the mix to provide some vegetative cover during the fall and Winter months. Acceptable nurse crops are Winter Wheat (5 lbs PLS/acre) or Regreen (5 lbs/acre).

Perennial grasses can be seeded using a drill seeder in areas previously planted with temporary grass cover. In this case, the annual grass shall be mowed prior to seeding. Broadcast seeding of permanent grasses should not be done with a live or dead crop of annual grasses without first reworking and preparing the topsoil.

Seed mixes for projects including or adjacent to Parks, Recreation & Open Space Department properties and facilities (existing and future) will be determined by the Parks, Recreation & Open Space Department. Projects funded by the Parks, Recreation & Open Space Department will be required to comply with the Department's standard specifications regarding seeding, mulching and maintenance. All projects including Parks, Recreation & Open Space Department properties and facilities will be required to receive approval of the Department prior to final acceptance of the vegetative cover.

CITY OF AURORA, COLORADO

Clay 2 Jts 7/1/10
AURORA WATER DEPARTMENT DATE

Kevin Wegener 9-2-10
CITY ENGINEER DATE

SEEDING & MULCHING

5 OF 7



STANDARD

Temporary Seeding - should be established as quickly as possible in areas where work has been completed or when there will be no work for an extended period of time. Site planning and phasing should include measures to ensure that disturbed areas are seeded within fourteen (14) calendar days after final grading, earth disturbance activities have been completed or when work is suspended for longer than thirty (30) days.

Key Installation and Maintenance Requirements:

- Seeding should only be applied after appropriate seedbed and soil preparations have been made to ensure the seedbed is conducive to plant growth. This may include soil amendments and/or grading and tilling
- Seed shall only be applied by drill seeding equipment.
- Seeded areas shall be covered with crimped straw mulch or erosion blankets to protect the seedbed and facilitate germination.
- Seeded areas shall be inspected to verify germination, vegetative growth, and adequate ground cover. Seeded areas that fail to develop uniform, established cover shall be reseeded



Disturbed areas without adequate vegetative cover (temporary or permanent) are vulnerable to surface erosion, such as this example.

CITY OF AURORA, COLORADO

Chris S. [Signature] 1/15/10
AURORA WATER DEPARTMENT DATE

Kevin [Signature] 1-15-10
CITY ENGINEER DATE

SEEDING & MULCHING

6 OF 7



STANDARD

Mulching - consists of evenly distributing straw over a disturbed area to provide for temporary stabilization or protection for a seed bed. The straw must be adequately secured by crimping the mulch into the ground to provide immediate protection against raindrop and wind erosion for exposed soils and promote the growth of vegetation by providing moisture retention and protection of seedbeds against extremes in temperature.

Key Installation and Maintenance Requirements:

- Mulch should be applied along the contour of the grade or slope and mechanically anchored to a depth of at least 3-inches. Mulch should be applied uniformly, and maintained at a rate of coverage that will allow no more than 10% of the surface to be exposed (2 ½ tons per acre minimum). In other words, 90% of the area shall be properly crimped with the mulch standing vertically. Mulch that is simply lying on the ground does not meet the City's requirements.
- Inspections should verify the integrity of the mulch application, installation and the need for re-application. For temporary stabilization and for applications to protect seed bed, mulch should be reapplied when coverage does not meet the installation criteria.
- Hydro mulching is not appropriate unless an irrigation system is operated to facilitate germination.



Steep slopes (such as the example below) and active drainage swales are not appropriate applications for mulching. Installations need to be evaluated for density and uniformity of cover, and proper anchoring. Areas with poor coverage and sparse vegetative cover need to be evaluated for re-application.



CITY OF AURORA, COLORADO

Chris 2 Str 9/1/10
AURORA WATER DEPARTMENT DATE
Kevin W. Jensen 9-2-10
CITY ENGINEER DATE

SEEDING & MULCHING

7 OF 7



STANDARD

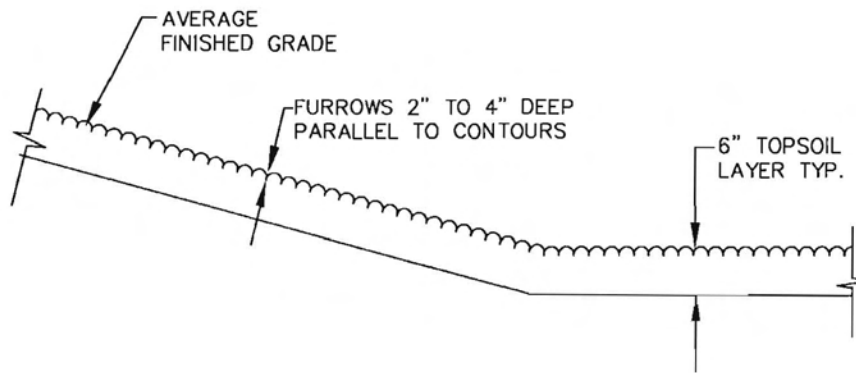
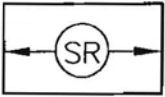

NOTES:

1. SURFACE ROUGHENING SHALL BE PROVIDED ON ALL FINISHED GRADES (SLOPES AND "FLAT" AREAS) WITHIN 2 DAYS OF COMPLETION OF FINISHED GRADE (FOR AREAS NOT RECEIVING TOPSOIL) OR WITHIN 2 DAYS OF TOPSOIL PLACEMENT.
2. SHALL BE INSTALLED AS AN INTERIM EROSION CONTROL MEASURE ON DISTURBED AREAS THAT ARE NOT CURRENTLY BEING WORKED.
3. AREAS WHERE BUILDING FOUNDATIONS, PAVEMENT, OR SOD IS TO BE PLACED WITHIN 7-DAYS OF FINISHED GRADING DO NOT NEED TO BE SURFACE ROUGHENED.
4. DISTURBED SURFACES SHALL BE ROUGHENED USING RIPPING OR TILLING EQUIPMENT ALONG THE CONTOUR OR TRACKING UP AND DOWN A SLOPE USING EQUIPMENT TREADS.
5. VEHICLES AND EQUIPMENT SHALL GENERALLY BE CONFINED TO ACCESS DRIVES AND SHALL NOT BE DRIVEN OVER AREAS THAT HAVE BEEN SURFACE ROUGHENED.
6. IN NON-TURF GRASS FINISHED AREAS, SEEDING AND MULCHING SHALL TAKE PLACE DIRECTLY OVER SURFACE ROUGHENED AREAS WITHOUT FIRST SMOOTHING OUT THE SURFACE.
7. IN AREAS NOT SEEDED AND MULCHED AFTER SURFACE ROUGHENING, SURFACES SHALL BE RE-ROUGHENED AS NECESSARY TO MAINTAIN GROOVE DEPTH AND SMOOTH OVER ANY RILL EROSION.

SOURCE: ADAPTED FROM
DOUGLAS COUNTY GESC
STANDARD DETAILS

CITY OF AURORA, COLORADO

[Signature] 6-5-09
AURORA WATER DEPARTMENT DATE

[Signature] 6-4-09
CITY ENGINEER DATE

SURFACE ROUGHENING

1 OF 4



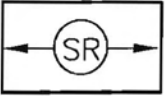

STAIR STEPPING CUT SLOPES

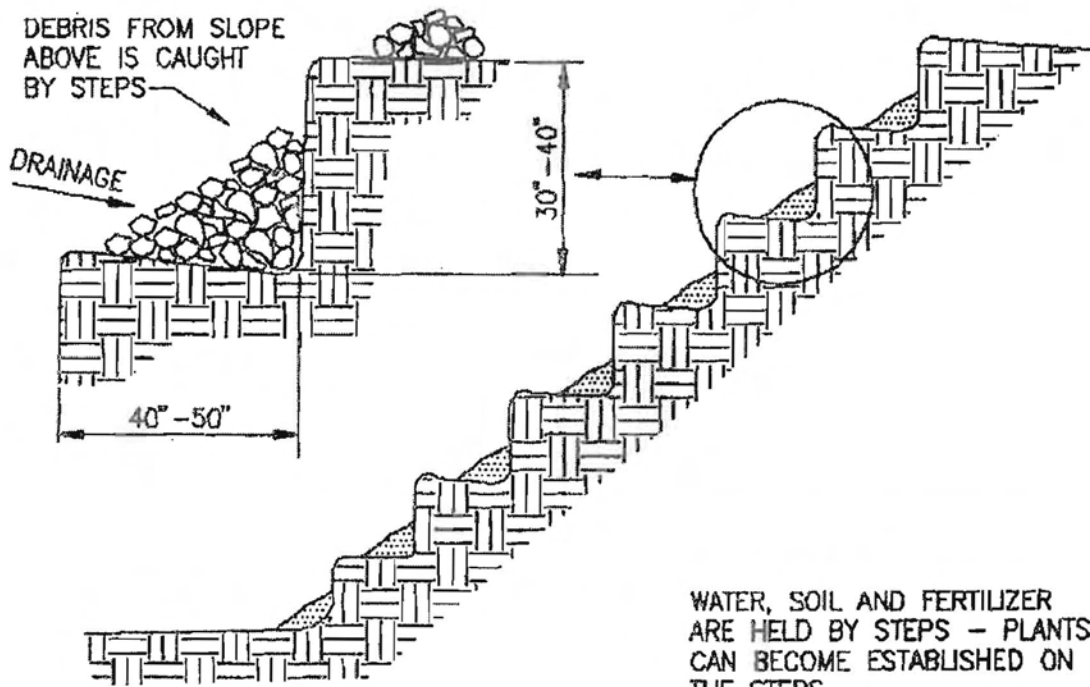

SOURCE: VA. DSWC

CITY OF AURORA, COLORADO
Joseph J. W... 6-5-09
AURORA WATER DEPARTMENT DATE
Kevin Wegener 6-4-09
CITY ENGINEER DATE

SURFACE ROUGHENING

2 OF 4
SR

STANDARD
GROOVING SLOPES

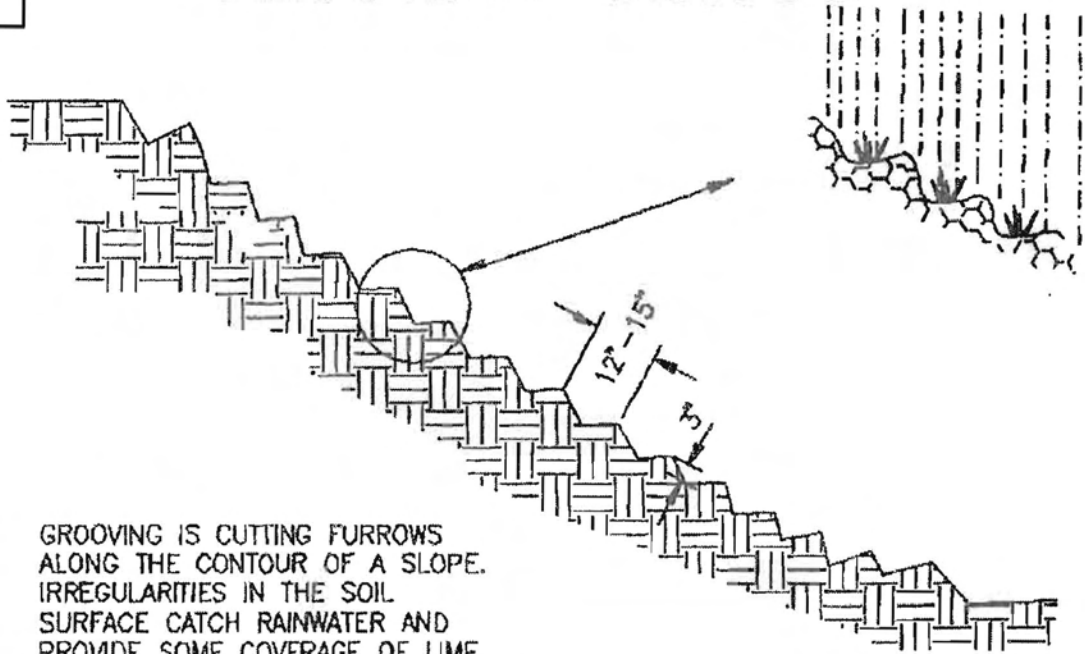
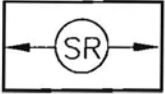

GROOVING IS CUTTING FURROWS ALONG THE CONTOUR OF A SLOPE. IRREGULARITIES IN THE SOIL SURFACE CATCH RAINWATER AND PROVIDE SOME COVERAGE OF LIME, FERTILIZER AND SEED.

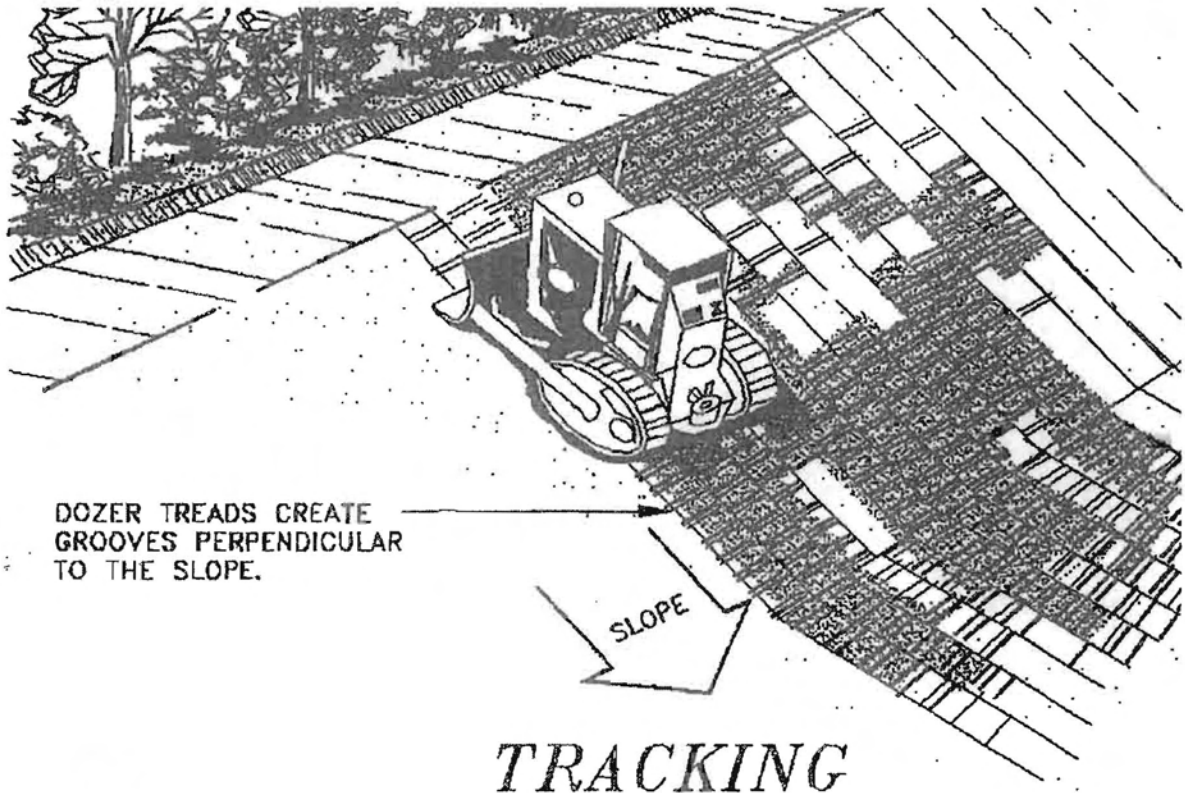

DOZER TREADS CREATE GROOVES PERPENDICULAR TO THE SLOPE.

TRACKING

SOURCE: VA. DSWC

CITY OF AURORA, COLORADO

John J. W. [Signature] 6-5-09
 AURORA WATER DEPARTMENT DATE
Kevin Wegener 6-4-09
 CITY ENGINEER DATE

SURFACE ROUGHENING

3 OF 4



STANDARD

Surface Roughening – installed by ripping, scarifying or disking along the contour of disturbed, graded areas. The function of this procedure is to increase the surface area and create variations in the soil surface to facilitate plant establishment, moisture retention and minimize wind and soil erosion. Roughening shall be used as a short-term, temporary means of stabilization and erosion control for dormant areas, or areas that have no activity and are in queue for future work.

Key Installation and Maintenance Requirements:

- Disturbed surfaces shall be roughened using ripping or tilling equipment on the contour of the grade
- Inspections shall be conducted to verify the integrity of controls. Areas where roughening has lost ability to function effectively shall be re-groomed/graded to redefine grooves, steps or furrows.



Disturbed areas with inappropriate grading controls are susceptible to erosion, such as this example on the right. Grooving running up and down a grade will facilitate erosion.



CITY OF AURORA, COLORADO

Chris 28th 1/12/10
AURORA WATER DEPARTMENT DATE

Kevin Wegener 1-15-10
CITY ENGINEER DATE

SURFACE ROUGHENING

4 OF 4



STANDARD

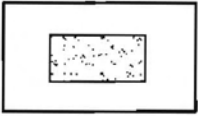

SOURCE: ADAPTED FROM
DOUGLAS COUNTY GESC
STANDARD DETAILS

STAGING AREA IS FOR PARKING,
STORAGE, LOADING AND
UNLOADING LANDSCAPE MATERIALS
AND EQUIPMENT. STABILIZE WITH
3" MIN. THICKNESS CRUSHED ROCK
MATERIAL (RECYCLED CONCRETE
AND RECYCLED ASPHALT
ARE NOT ACCEPTABLE).

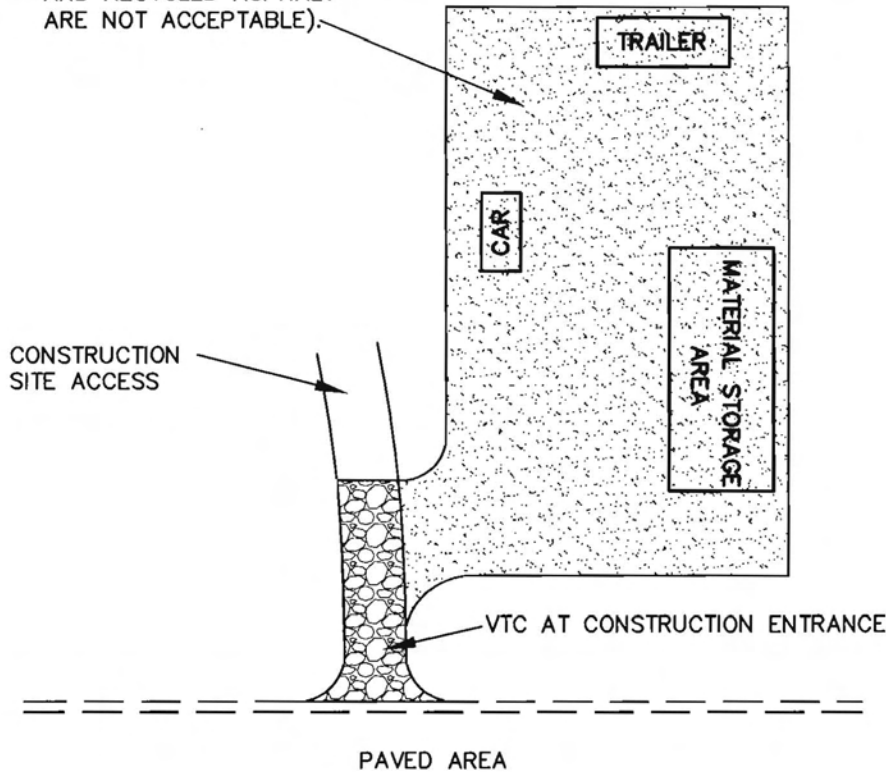

NOTES:

1. SEE PLAN VIEW FOR GENERAL LOCATION OF STAGING AREA. CONTRACTOR MAY MODIFY LOCATION AND SIZE OF STABILIZED STAGING AREA WITH CITY APPROVAL.
2. STABILIZED STAGING AREA SHALL BE LARGE ENOUGH TO FULLY CONTAIN PARKING, STORAGE, AND UNLOADING AND LOADING OPERATIONS.
3. IF REQUIRED BY THE CITY, SITE ACCESS ROADS SHALL BE STABILIZED IN THE SAME MANNER AS THE STAGING AREA.
4. STAGING AREA SHALL BE STABILIZED PRIOR TO ANY OTHER OPERATIONS ON THE SITE.
5. THE STABILIZED STAGING AREA SHALL CONSIST OF A MINIMUM OF 3" OF 1 1/2" OR LARGER CRUSHED ROCK MATERIAL (RECYCLED CONCRETE AND RECYCLED ASPHALT ARE NOT ACCEPTABLE).
6. ADDITIONAL CONSTRUCTION FENCE AND OR PERIMETER BMP'S MAY BE REQUIRED.
7. GEOTEXTILE FABRIC UNDERLAYMENT IS REQUIRED ON ALL CITY OF AURORA PARKS, RECREATION & OPEN SPACE PROJECTS AND RECOMMENDED ON ALL OTHER PROJECTS. GEOTEXTILE SHALL EXTEND A MINIMUM OF 5 FEET BEYOND CRUSHED ROCK MATERIAL.

CITY OF AURORA, COLORADO

Chris P... 5/12/10
AURORA WATER DEPARTMENT DATE
Kevin W... 1-15-10
CITY ENGINEER DATE

STABILIZED
STAGING AREA

1 OF 2



STANDARD

Stabilized Staging Area - consists of installing a layer of rock in areas to be used for trailers, personnel parking, and/or material storage. A stabilized staging area reduces the likelihood that the vehicles entering and exiting a site are going to come in contact with mud, sediment, and/or debris and subsequently transport them onto paved surfaces, as well as minimizing runoff leaving the construction site.

Key Installation and Maintenance Requirements:

- Staging areas should be large enough to fully contain parking, storage, and unloading and loading operations
- Use of recycled concrete or asphalt is not an acceptable substitute for rock
- Staging areas should be refreshed with new rock, as needed, to adequately maintain a stabilized surface.



Driving and parking on disturbed areas should be discouraged, as it can contribute to sediment tracking, especially during inclement conditions as shown here.

CITY OF AURORA, COLORADO

Chris 2/8/10
AURORA WATER DEPARTMENT DATE

Kevin Wegener
CITY ENGINEER DATE

STABILIZED
STAGING AREA

2 OF 2



STANDARD

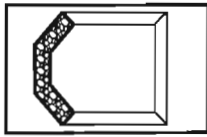

FLOW →

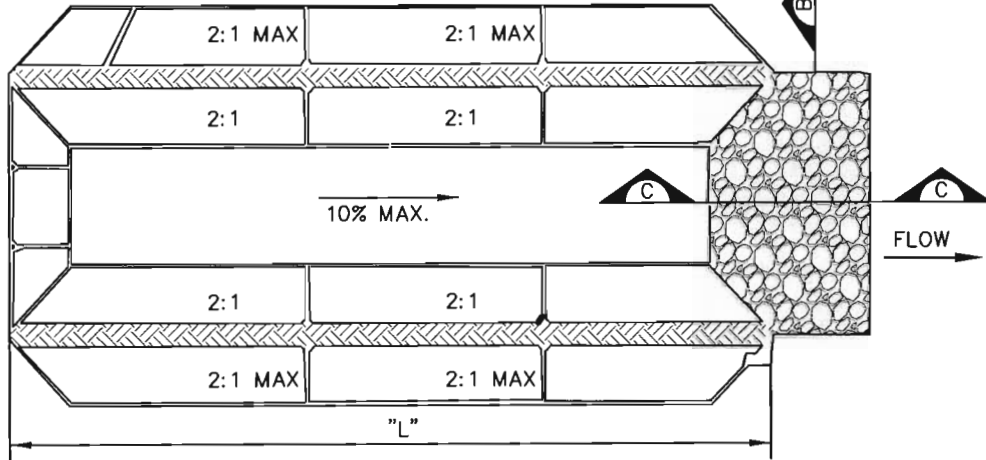

SOURCE: ADAPTED FROM
DOUGLAS COUNTY GESC
STANDARD DETAILS

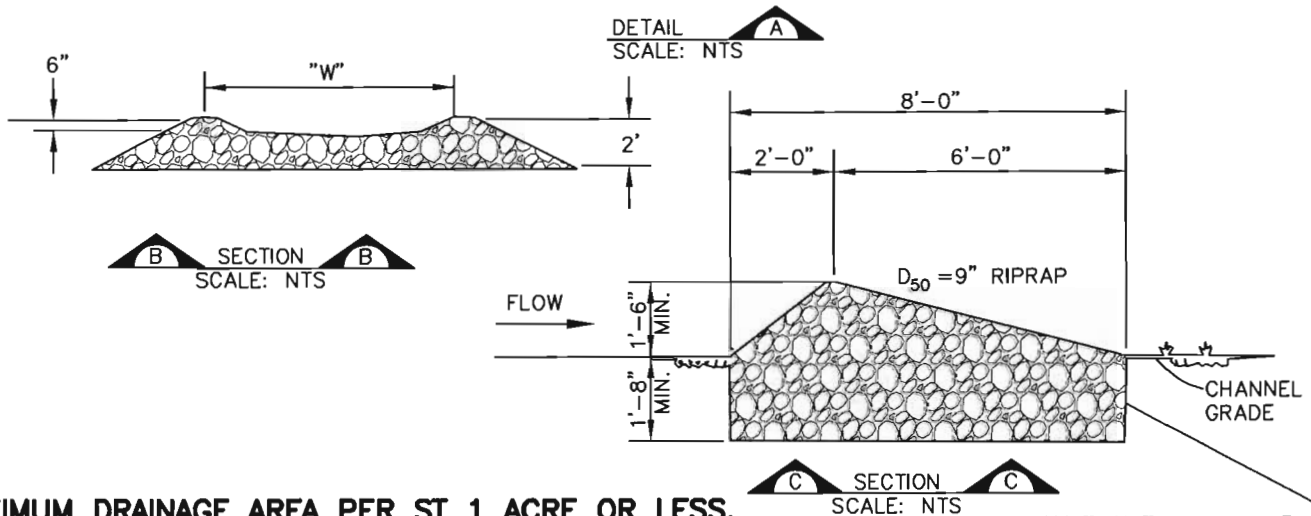

MAXIMUM DRAINAGE AREA PER ST 1 ACRE OR LESS.

NOTES:

1. SEE PLAN VIEW FOR: -LOCATION, LENGTH, SLOPE AND WIDTH OF SEDIMENT TRAP.
2. SEDIMENT TRAPS SHALL BE INSTALLED PRIOR TO ANY LAND DISTURBING ACTIVITIES.
3. SEDIMENT TRAP BERM SHALL BE CONSTRUCTED FROM MATERIAL FROM EXCAVATION. THE BERM SHALL BE COMPACTED TO 95% OF THE MAXIMUM DENSITY IN ACCORDANCE WITH ASTM D698.
4. RIPRAP OUTLET SHALL BE CONSTRUCTED WITH $D_{50}=9"$ RIPRAP WITH A MINIMUM OVERFLOW OF 6". RECYCLED CONCRETE IS NOT ACCEPTABLE.
5. THE TOP OF THE EARTHEN BERM SHALL BE A MINIMUM OF 6" HIGHER THAN THE TOP OF THE RIPRAP OUTLET STRUCTURE.
6. THE ENDS OF THE RIPRAP OUTLET STRUCTURE SHALL BE MINIMUM OF 6" HIGHER THAN THE CENTER OF THE OUTLET STRUCTURE.
7. SEDIMENT ACCUMULATED UPSTREAM OF RIPRAP SHALL BE REMOVED WHEN THE UPSTREAM SEDIMENT DEPTH IS WITHIN $\frac{1}{2}$ THE HEIGHT OF THE RIPRAP OUTLET.
8. SEDIMENT TRAPS SHALL REMAIN IN PLACE UNTIL THE UPSTREAM DISTURBED AREA IS STABILIZED AND GRASS COVERAGE IS APPROVED.
9. IN APPLICATIONS WHERE DISTURBED AREAS ARE GREATER THAN 1 ACRE, MULTIPLE TRAPS OR A SEDIMENT BASIN IS REQUIRED.
10. DO NOT INSTALL WITHIN DRIPLINE OF EXISTING TREES.

EXCAVATION TO NEXT LINE
AVOID OVEREXCAVATION(TYP.)

CITY OF AURORA, COLORADO

Mary 28th 9/1/10
AURORA WATER DEPARTMENT DATE
Kevin Wegener 9.2.10
CITY ENGINEER DATE

SEDIMENT TRAP

1 OF 2



STANDARD

Sediment Trap – is constructed with an earthen berm, creating a small upstream basin that acts to trap runoff and facilitate the settling of suspended particles, similar to a sediment basin. The discharge or outlet point is established with a riprap armored weir, to stabilize the discharge section. Traps can be used when upstream drainage areas are less than 1 acre. In applications where disturbed areas are greater than 1 acre, multiple Traps or a Sediment Basin is required.

Key Installation and Maintenance Requirements:

- Traps need to be installed with other appurtenant features such as berms or diversions to facilitate flows being conveyed to the trap
- Installed features need to be routinely inspected to ensure on-going good operating condition and that the features are maintained to coincide with the installation detail.



All entrapment facilities, such as Sediment Traps and Basins, require an adequate means to discharge. Features that are not installed correctly or not maintained in good operating condition are prone to failure, such as the example here. The embankment here failed after the accumulated runoff overtopped and eroded the berm.



CITY OF AURORA, COLORADO

[Signature]
AURORA WATER DEPARTMENT

1/2/10
DATE

[Signature]
CITY ENGINEER

1.15.10
DATE

SEDIMENT TRAP

2 OF 2



STANDARD

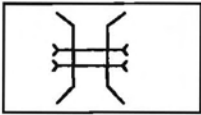

1/2 DIAMETER OF PIPE
OR 12", WHICHEVER IS
GREATER

COARSE AGGREGATE
6" DEEP
(1 1/2" MIN.)

CAPACITY OF PIPE CULVERTS
TOGETHER = BANK FULL FLOW

LARGE ANGULAR ROCK
OVER EARTHFILL, D₅₀

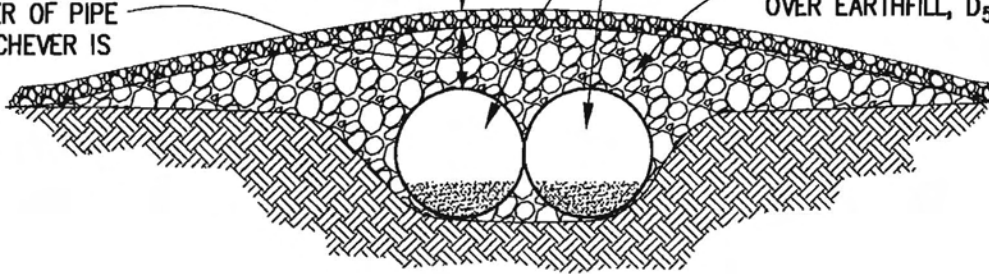

COARSE AGGREGATE

FLOW

LARGE ANGULAR
ROCK OVER EARTHFILL, D₅₀

← 25' MINIMUM →

TOP OF BANK

STREAM CHANNEL

← 25' MINIMUM →

TOP OF BANK

DESIGN CRITERIA:

- THIS DESIGN IS INTENDED FOR ALL STREAMS ONLY (SEE NOTES), INCLUDING DRY CREEK BEDS
- AS A MINIMUM, DESIGN THE STRUCTURE TO PASS BANKFULL FLOW OR PEAK FLOW WITHOUT OVERTOPPING.
- ENSURE THAT DESIGN FLOW VELOCITY AT THE OUTLET OF THE CROSSING STRUCTURE IS NONEROSIVE FOR THE RECEIVING STREAM CHANNEL. SEE VOL. II, MAJOR DRAINAGE, SECTION 5.3

NOTES:

1. SEE PLAN VIEW FOR:
 - LOCATIONS OF TEMPORARY STREAM CROSSING.
 - FOR CULVERT CROSSING: LENGTH, "L"; CREST LENGTH, "CL"; CROSSING HEIGHT, "H"; DEPTH, "D"; RIPRAP SIZE, D⁵⁰; CULVERT DIAMETER, "CD"; AND NUMBER, TYPE AND CLASS OR GAUGE OF CULVERTS.
2. ANY DAMAGE TO STREAM CROSSING OR EXISTING STREAM CHANNEL DURING BASEFLOW OR FLOOD EVENTS SHALL BE THE CONTRACTOR'S RESPONSIBILITY.
3. FOR A TEMPORARY STREAM CROSSING THAT WILL CARRY LOADS, THE TEMPORARY STREAM CROSSING MUST BE DESIGNED BY THE DESIGN ENGINEER.
4. SEDIMENT ACCUMULATED UPSTREAM OF STREAM CROSSINGS SHALL BE REMOVED WHEN THE SEDIMENT DEPTH UPSTREAM OF THE CROSSING IS AN AVERAGE DEPTH OF 12".
5. STREAM CROSSINGS ARE TO REMAIN IN PLACE UNTIL NO LONGER NEEDED, BUT SHALL BE REMOVED PRIOR TO THE END OF CONSTRUCTION.
6. WHEN STREAM CROSSINGS ARE REMOVED, THE DISTURBED AREA SHALL BE DRILL SEEDED AND COVERED WITH EROSION CONTROL BLANKET OR OTHERWISE STABILIZED IN A MANNER APPROVED BY THE CITY.
7. A TEMPORARY ACCESS BRIDGE MAY BE USED. MUST BE APPROVED BY ENVIRONMENTAL INSPECTOR PRIOR TO INSTALLATION.
8. CULVERTS MUST BE SIZED BY THE STATE OF DESIGN ENGINEER LICENSED IN THE STATE OF COLORADO. SIZE CALCULATIONS MUST BE INCLUDED IN THE SWMP REPORT.
9. TEMPORARY STREAM CROSSINGS SHALL NOT BE LOCATED WITHIN THE DRIFLINE OF AN EXISTING TREE TO BE PRESERVED, WITHOUT THE WRITTEN APPROVAL OF THE CITY ARBORIST.

CITY OF AURORA, COLORADO

Jon Z. Weger 6-5-09
AURORA WATER DEPARTMENT DATE
Kevin Weger 6-4-09
CITY ENGINEER DATE

TEMPORARY
STREAM CROSSING

1 OF 2



STANDARD

Stream Crossing - features are installed to prevent construction equipment from damaging the waterway, blocking fish migration, and tracking sediment and other pollutants into the waterway. Culvert crossings will be established with a temporary, structural span that will permit the uninterrupted flow of the watercourse. In either instance, excavation of the existing channel banks is not allowed and, in general, disturbances are to be kept to a minimum.

Key Installation and Maintenance Requirements:

- Contractor should confirm that all related in-stream permitting is obtained prior to installing temporary stream crossings and that all work will be in compliance with such permitting
- These features will be installed at all stream, gulch and creek crossings, even if the drainage way or watercourse is normally dry
- Ford style crossings are not allowed
- Rock cover must be maintained in place to cover the entire feature
- Use of recycled concrete or asphalt is not an acceptable substitute for rock.



Features must be designed and installed to be fully functional for predictable, seasonal weather patterns and live flows. This feature has been by-passed and overwhelmed, due to the installation of incorrectly sized piping.



CITY OF AURORA, COLORADO

[Signature]
AURORA WATER DEPARTMENT

1/12/10
DATE

[Signature]
CITY ENGINEER

1.15.10
DATE

TEMPORARY
STREAM CROSSING

2 OF 2



STANDARD

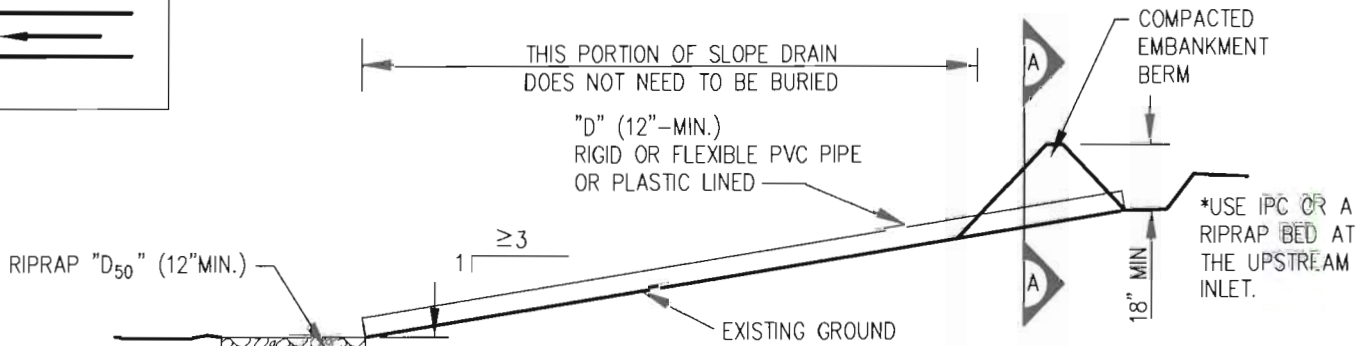
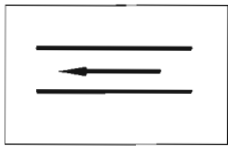

SIZE OF PVC PIPE

DRAINAGE AREA (ACRES)	PIPE SIZE (INCHES)
<1.5	12"
<5.0	18"
<10.0	24"

SLOPE DRAIN - DETAIL

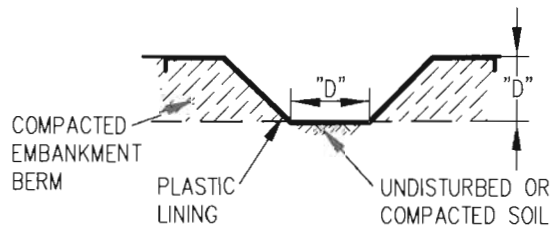
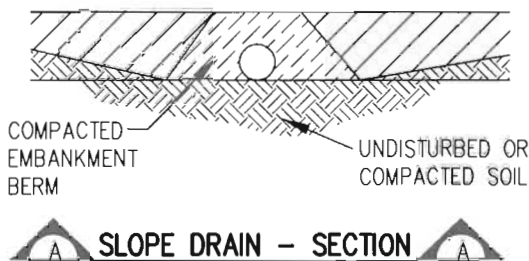

PLASTIC LINED DRAIN CHANNEL - SECTION

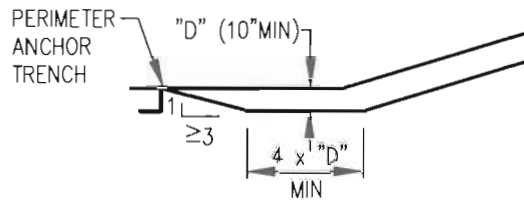
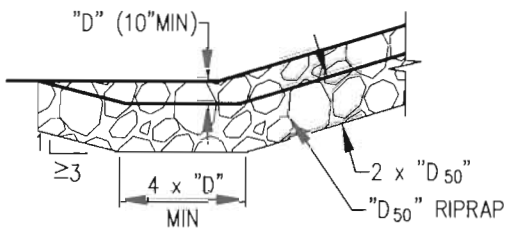

TERMINATION OF RIPRAP LINED SLOPE DRAIN - DETAIL

TERMINATION OF PLASTIC LINED SLOPE DRAIN CHANNEL - DETAIL

NOTES:

- SEE PLAN VIEW FOR:
 - LOCATION AND LENGTH OF SLOPE DRAIN
 - PIPE DIAMETER, "D", AND RIPRAP SIZE, "D₅₀" (TO BE SPECIFIED BY ENGINEER)
- SLOPE DRAIN DIMENSIONS SHALL BE CONSIDERED MINIMUM DIMENSIONS; CONTRACTOR MAY ELECT TO INSTALL LARGER FACILITIES. ANY DAMAGE TO SLOPE OR SLOPE DRAIN DURING RUNOFF EVENTS SHALL BE THE CONTRACTOR'S RESPONSIBILITY.
- SLOPE DRAINS INDICATED ON PLAN SHALL BE INSTALLED PRIOR TO ANY UPSTREAM LAND-DISTURBING ACTIVITIES.
- FOR TEMPORARY SLOPE DRAINS, PIPE MAY BE INSTALLED ON TOP OF SLOPE; HOWEVER, 12" MIN. COVER AT TOP OF SLOPE SHALL BE PROVIDED.
- A RIPRAP PAD SHALL BE PLACED AT THE OUTFALL OF THE SLOPE DRAIN, RECYCLED CONCRETE IS NOT ACCEPTABLE.
- ENTIRE CHANNEL MAY BE RIPRAP OR PLASTIC LINED IF DESIRED, IN LIEU OF PIPE DRAIN.
- DO NOT FILL OR EXCAVATE WITHIN DRIPLINE OF EXISTING TREES.

SOURCE: ADAPTED FROM DOUGLAS COUNTY GESC STANDARD DETAILS

CITY OF AURORA, COLORADO

City 2 9/1/10
 AURORA WATER DEPARTMENT DATE
Kevin W. Jensen 9.2.10
 CITY ENGINEER DATE

TEMPORARY SLOPE DRAIN

1 OF 2



STANDARD

Temporary Slope Drain - is a small culvert, pipe or plastic rundown installed to safely convey runoff down a grade, incline or channel bank to reduce the occurrence of rill and gully erosion. Also referred to as an Embankment Protector.

Key Installation and Maintenance Requirements:

- Features should be adequately installed to avoid by-pass
- Pipes, if used, shall be appropriately coupled and anchored to prevent disruption.



Slope Drains should be installed to safely convey run-off down a grade and protect unstabilized areas against erosion.

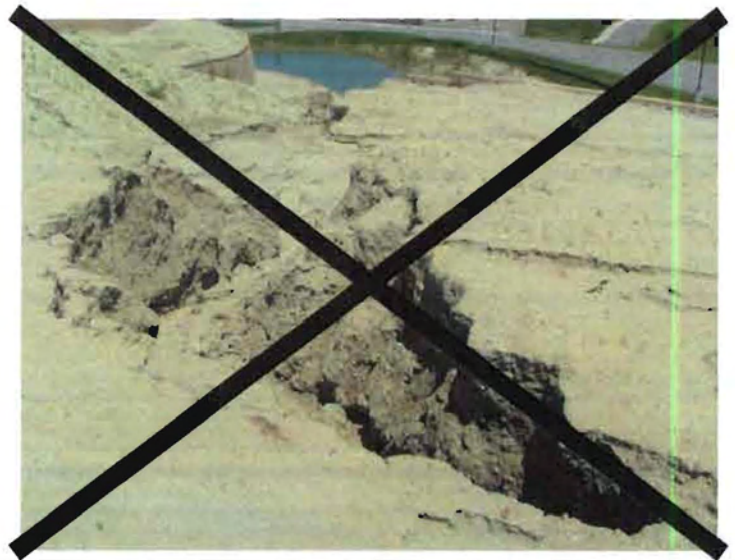

CITY OF AURORA, COLORADO
Chris J. [Signature] 1/12/10
AURORA WATER DEPARTMENT DATE
Kevin Wegener 1-15-10
CITY ENGINEER DATE

TEMPORARY
SLOPE DRAIN

2 OF 2



STANDARD

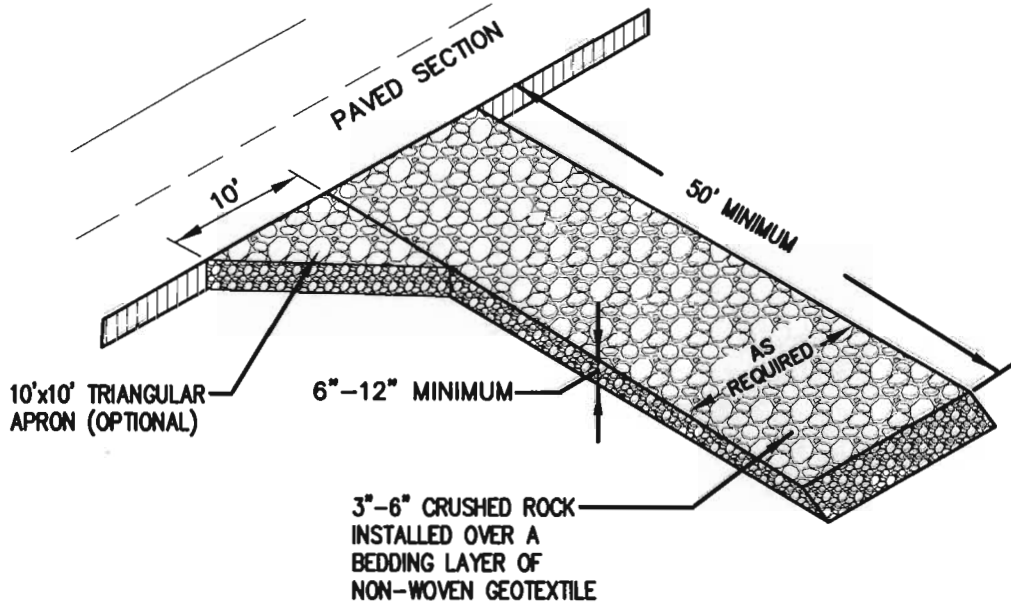
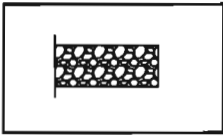

NOTES:

1. VEHICLE TRACKING CONTROL PADS SHALL BE INSTALLED AT ALL INGRESS/EGRESS POINTS WHERE VEHICULAR ACCESS TRANSITIONS FROM PAVED SECTIONS TO DISTURBED AREAS.
2. THE ROCK FOR THE VTC PAD SHALL CONSIST OF HARD, ANGULAR, DENSE AND DURABLE STONE. ROUNDED STONE, BOULDERS, RECYCLED CONCRETE AND RECYCLED ASPHALT ARE NOT ACCEPTABLE SUBSTITUTIONS. ROCK SHALL BE GROOMED IN PLACE SUCH THAT THE ROCK IS LOCKED DOWN, CREATING A PAVING EFFECT THAT DOES NOT DETER VEHICULAR TRAFFIC.
3. ANY CRACKED OR DAMAGED GUTTER OR CURB SECTIONS SHALL BE REPLACED BY THE PERMITTEE.
4. PAD WILL BE REPAIRED/REFRESHED AS NEEDED, TO MAINTAIN FUNCTION AND INTEGRITY OF THE FEATURE.
5. VTC PADS SHALL BE INSTALLED AT ALL CONCRETE WASHOUT AREAS AND AT STABILIZED STORAGE AND STAGING AREAS.
6. VEHICLE TRACKING CONTROL PADS SHALL CONSIST OF HARD DENSE, DURABLE STONE, ANGULAR IN SHAPE AND WITH A MAXIMUM SIZE OF 6" AND A MINIMUM SIZE OF 3". THE STONE SHALL HAVE A SPECIFIC GRAVITY OF AT LEAST 2.6. CONTROL OF GRADATION WILL BE BY VISUAL INSPECTION.
7. A STOP SIGN INSTALLED IN ACCORDANCE WITH THE MANUAL ON UNIFORM TRAFFIC CONTROL DEVICES (MUTCD), AS AMENDED, SHALL BE INSTALLED FOR EXISTING TRAFFIC AT THE VTC.
8. DO NOT INSTALL WITHIN DRIPLINE OF EXISTING TREES.

CITY OF AURORA, COLORADO <i>Clay 2 St</i> 8/1/10 AURORA WATER DEPARTMENT DATE	CITY ENGINEER DATE <i>Kevin Wegman</i> 9.2.10
--	---

VEHICLE TRACKING
CONTROL

1 OF 2



STANDARD

Vehicle Tracking Control – features and controls should be used to control sediment tracking from disturbed areas onto paved sections. Vehicle Tracking Control pads shall be provided at all entrance/exit points from paved sections to disturbed areas. A location should be selected that accounts for the safety of the traveling public and avoids disturbance of trees, desirable vegetation, and low-lying, wet areas. Steep grades (greater than eight percent) shall be avoided. These features are intended to reduce the likelihood that vehicles entering and exiting a site will come in contact with mud and help strip mud from tires prior to vehicles leaving the area of disturbance.

Key Installation and Maintenance Requirements:

- Vehicle Track Pads shall be installed at every access point to or from the site
- The use of recycled concrete or asphalt, is not an acceptable substitute for rock
- VTC Pads shall be maintained to continuously conform to this installation detail
- Whenever sediment is tracked onto a paved section, regardless of the size of the site, the section(s) shall be promptly cleaned
- No ramps of dirt, gravel, asphalt, or wood, are allowed in the curb flowline.



Installations of dirt ramps in the curb flowlines are not allowed. Paved sections and curb flowlines must be kept clean of debris and sediment.



CITY OF AURORA, COLORADO

Cathy 2/2/10
AURORA WATER DEPARTMENT DATE
Kevin Wegener 1.15.10
CITY ENGINEER DATE

VEHICLE TRACKING
CONTROL

2 OF 2



STANDARD

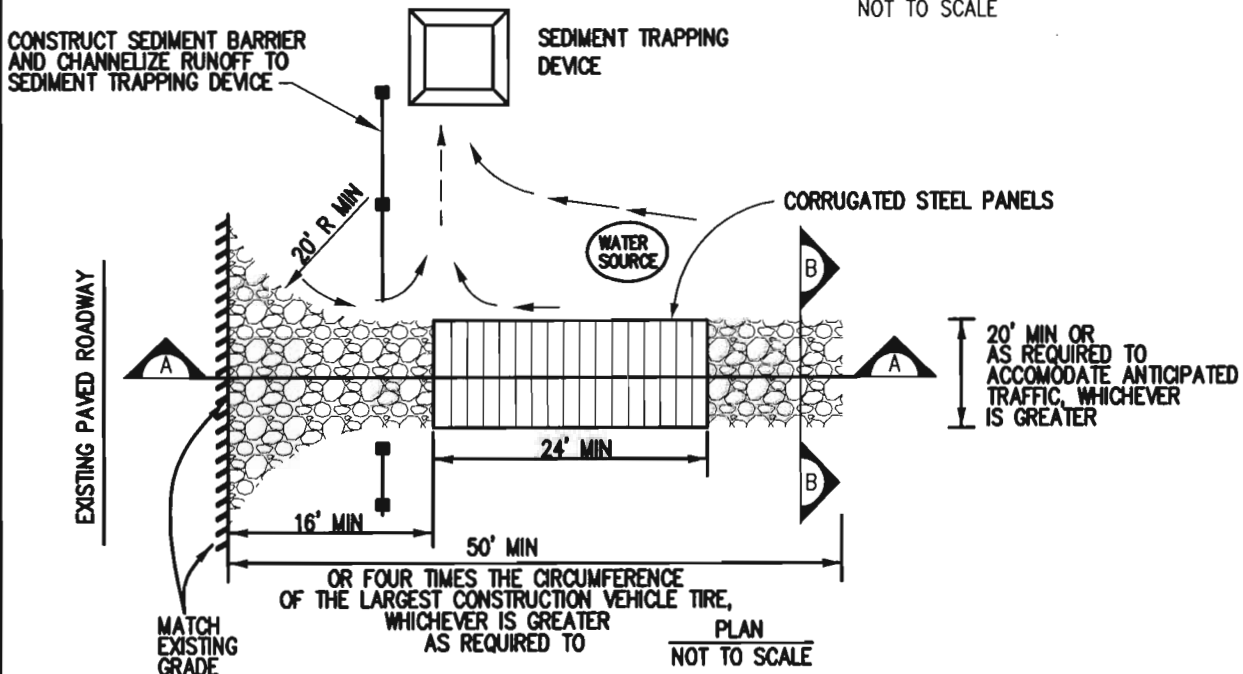
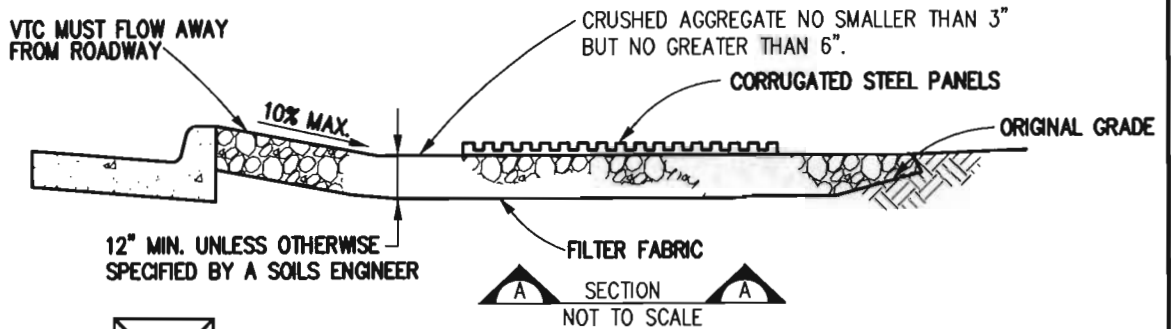
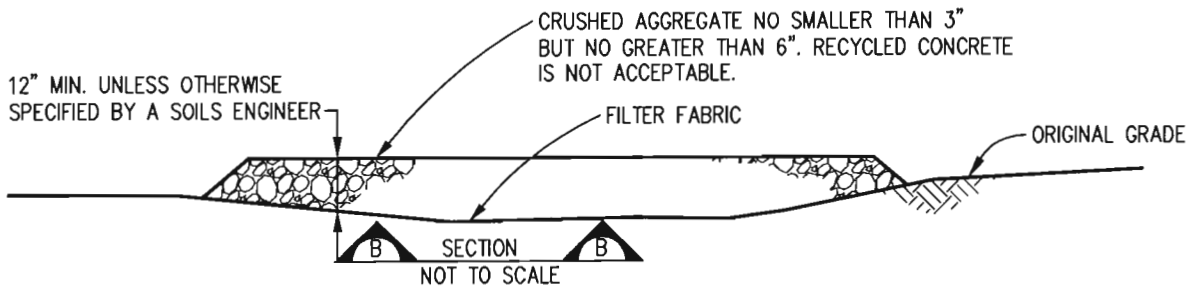

NOTES:

1. THE CITY RESERVES THE RIGHT TO REQUIRE VEHICLE TRACKING CONTROL WITH WHEEL WASH FACILITIES AT SITES WHERE TRACKING ONTO PAVED AREAS BECOMES A SIGNIFICANT PROBLEM.
2. WHEN VEHICLE TRACKING CONTROL WITH WHEEL WASH FACILITIES ARE USED, ALL WHEELS ON EVERY VEHICLE LEAVING THE SITE SHALL BE CLEANED OF MUD USING A PRESSURE-WASHER. THE CONTRACTOR SHALL BE RESPONSIBLE FOR OBTAINING A WATER SOURCE.
3. VEHICLE TRACKING CONTROL PADS SHALL CONSIST OF HARD, DENSE, DURABLE STONE, ANGULAR IN SHAPE, AND WITH A MAXIMUM SIZE OF 6" AND A MINIMUM SIZE OF 3". THE STONE SHALL HAVE A SPECIFIC GRAVITY OF AT LEAST 2.6. CONTROL OF GRADATION WILL BE BY VISUAL INSPECTIONS.
4. ANY CRACKED OR DAMAGED CURB AND GUTTER AND SIDEWALK SHALL BE REPLACED BY THE PERMITTEE.
5. A STOP SIGN INSTALLED IN ACCORDANCE WITH THE MANUAL ON UNIFORM TRAFFIC CONTROL DEVICES (MUTCD), AS AMENDED, SHALL BE INSTALLED FOR EXITING TRAFFIC AT THE VTC.
6. DO NOT INSTALL WITHIN DRIPLINE OF EXISTING TREES.

CITY OF AURORA, COLORADO

Chris J. St... 9/1/10
 AURORA WATER DEPARTMENT DATE
Kevin Wegener 9.2.10
 CITY ENGINEER DATE

VTC WITH WHEEL WASH

1 OF 2



STANDARD

Vehicle Tracking Control With Wheel Wash – is installed to facilitate washing sediment from vehicle tires when exiting a site or transitioning from a disturbed area onto a paved section. The wash rack enables the washed sediment to drop below the rack and then be conveyed to a sediment trap or basin. Tires should be adequately cleaned of sediment to prevent tracking onto the adjoining paved section. A power washer may be used to supply appropriate water pressure to dislodge and clean the tires of sediment.

Key Installation and Maintenance Requirements:

- Ensure rack under drain has positive drainage to an adjoining entrapment feature, such as a Sediment Trap
- Conveyed run-off, from the wash rack to the sediment trap, should be managed so as not to create surface erosion
- Feature should be maintained in a clean and sediment free condition to function adequately and not contribute sediment to tires
- Sediment Trap, or other entrapment feature, needs to be inspected regularly to ensure good working order and functional capacity. Sediment Trap should not be discharging sediment off-site, onto paved sections, into watercourses or stormdrain inlets



Wash Rack grid installed in a VTC Pad.
Note the culvert pipe, for carrying discharges to an adjoining Sediment Trap



CITY OF AURORA, COLORADO

[Signature] 1/2/10
AURORA WATER DEPARTMENT DATE

[Signature] 1.15.10
CITY ENGINEER DATE

VTC WITH WHEEL WASH

2 OF 2



THIS PAGE IS INTENTIONALLY BLANK

Appendix E – SWMP Narrative Report Template and Design Drawings Checklists

The SWMP Narrative Report template shall be used for all SWMPs. These checklists are provided as a guide in preparing and checking SWMP Design Drawings for completeness. These checklists should be completed, signed by a Colorado licensed professional engineer, and submitted with the SWMP Narrative Report and Design Drawings.

THIS PAGE IS INTENTIONALLY BLANK

Stormwater Management Plan

for:

Insert Subdivision Name and Filing No.

Insert Project Name

Insert Project Site Location/Address

Insert City, State, Zip Code

Insert Project Site Telephone Number (if applicable)

Owner/Operator(s):

Insert Company or Organization Name

Insert Name

Insert Address

Insert City, State, Zip Code

Insert Telephone Number

Insert Fax/Email

Engineer Contact(s):

Insert Company or Organization Name

Insert Name

Insert Address

Insert City, State, Zip Code

Insert Telephone Number

Insert Fax/Email

SWMP Preparation Date: __/__/__

Estimated Project Dates:

Project Start Date: __/__/__

Project Completion Date: __/__/__

APPROVED FOR ONE YEAR FROM THIS DATE	
City Engineer	Date
Aurora Water Department	Date

“THIS STORMWATER MANAGEMENT PLAN HAS BEEN PLACED IN THE CITY OF AURORA FILE FOR THIS PROJECT AND HAS BEEN DETERMINED TO COMPLY WITH THE APPLICABLE CITY OF AURORA STORMWATER MANAGEMENT CRITERIA. ADDITIONAL STORMWATER MANAGEMENT, EROSION AND SEDIMENT CONTROL MEASURES MAY BE REQUIRED OF THE OWNER OR HIS/HER AGENTS, DUE TO UNFORESEEN EROSION PROBLEMS OR IF THE SUBMITTED PLAN DOES NOT FUNCTION AS INTENDED.”

“REVIEW OF THIS PLAN BY THE CITY OF AURORA SHALL NOT IMPLY THAT IT HAS BEEN REVIEWED FOR COMPLIANCE WITH THE REQUIREMENTS SET FORTH BY THE STATE OF COLORADO DEPARTMENT OF PUBLIC HEALTH AND ENVIRONMENT GENERAL PERMIT FOR STORMWATER DISCHARGES ASSOCIATED WITH CONSTRUCTION ACTIVITY.”

“SEE APPROVED STORMWATER MANAGEMENT PLAN DESIGN DRAWINGS (SITE PLAN) FOR SITE SPECIFIC BEST MANAGEMENT PRACTICES.”

Project Owner/Developer Signature Block

I have reviewed the information contained within the Stormwater Management Plan and accept responsibility for the requirements set forth.

Permittee/Affiliation
(type actual name)

Date

Plan Preparer Signature Block

I acknowledge my responsibility for the preparation of the Stormwater Management Plan.

CO Professional Engineer
(type actual name and affix PE stamp)

Date

Table of Contents

SECTION 1 SITE DESCRIPTION

- i Site Location
- ii Description of Adjacent Areas
 - a) Nature and Purpose of Construction Activity
 - b) Construction Sequence
 - c) Area
 - d) Topography, Soils, and Rainfall Data
 - e) Existing Vegetation
 - f) Potential Sources of Pollution
 - g) Non Stormwater Discharges
 - h) Receiving Waters
 - i) Site Features and Sensitive Areas to be Protected
 - j) Other Applicable Federal, State or Local Programs, Regulations or Restrictions

SECTION 2 DESIGN DRAWINGS

SECTION 3 STORMWATER MANAGEMENT CONTROLS

- a) SWMP Administrator and Important Contacts
- b) Identification of Potential Pollutant Sources
- c) BMPs for Stormwater Pollution Prevention

SECTION 4 FINAL STABILIZATION AND LONG TERM STORMWATER MANAGEMENT

- a) Final Stabilization Measures
- b) Seed Mix Information
- c) Final Stabilization Notes

SECTION 5 INSPECTIONS AND MAINTENANCE

SECTION 6 PROBABLE COST FOR INSTALLATION OF BMPs

SECTION 7 CALCULATIONS MADE FOR THE DESIGN

SECTION 8 VARIANCE REQUESTS

REFERENCES

SWMP APPENDIX A – Floodplain Information

SWMP APPENDIX B – Soils Information

SWMP APPENDIX C – Probable Cost Forms

SWMP APPENDIX D – Calculations

SWMP APPENDIX E – Variance Request Details

SWMP APPENDIX F – Vertical Construction Matrix

"Pursuant to Sections 138-440 and 138-442 of the Aurora Municipal Code, the Permittee shall locate, install, and maintain all Best Management Practices, including, but not limited to, erosion controls, sediment controls, drainage controls, and water quality BMPs as indicated in the approved Stormwater Management Plan (SWMP). The following notes are a requirement and shall be included in the SWMP narrative developed for this project and submitted for approval by the City. BMP installations shall be installed per the COA Standard Detail in effect at the time of installation or per the approved SWMP design drawing, a COA approved variance, or a COA approved design drawing plan amendment."

COA Stormwater Management Standard Notes

1. A City of Aurora Stormwater Quality Discharge Permit for Construction Activities must be issued by the City and executed by a COA Erosion Control staff prior to any earthwork activities. An on-site inspection will be conducted to verify the correct installation and adequacy of initial BMPs for the site. No earthwork, including clearing and grubbing, or demolition activities are to begin until the project site has passed an inspection and the City of Aurora Stormwater Quality Discharge Permit for Construction Activities has been executed. The Permittee is required to present the project's CDPHE-WQCD Stormwater Discharges Associated with Construction Activity Permit to the Inspector during the initial inspection. The Permittee shall designate a Stormwater Management Plan (SWMP) Administrator on the application for the City of Aurora Stormwater Quality Discharge Permit for Construction Activities. The SWMP Administrator will act as the project representative for any concerns or issues regarding environmental controls and stormwater management.
2. These requirements shall be the obligation of the Permittee, until such time as the Permit is properly closed, or otherwise allowed by the City to be voided, modified, transferred, re-assigned or replaced.
3. This SWMP narrative, the SWMP design drawings, and the Permittee's inspection and maintenance records are all components of required record keeping and shall be kept on site at all times and updated as required. These and any other pertinent records shall be provided to the City when requested.
4. Any discrepancy between this SWMP and any other approved Stormwater Management Plan for this site shall require compliance with the more restrictive valid, approved plan.
5. Streets shall be constructed with Rough Cut Street Control measures, surface roughened or otherwise temporarily stabilized with rough cut street controls within seven (7) days of completion of grading in the appropriate phase. If paving is to occur within fourteen (14) days after final grading, rough cut street controls shall be waived.
6. Inspection and maintenance of erosion and sediment control Best Management Practices (BMPs) are the continuous obligations of the Permittee. BMPs shall be inspected at a minimum every seven (7) days and within 24-hours after the end of a precipitation event that produces run-off, and following snowmelt events. If a site is temporarily idle and no construction activities will occur during the 48 hours following a storm event, the post-precipitation event (including

snowmelt) inspection shall be conducted prior to commencing construction activities on the site, but no later than 72 hours following the storm event. All necessary maintenance and repairs shall be initiated and completed on an on-going basis, as features are required to operate continuously. Inspections may need to be conducted at a greater frequency than noted above, to ensure features and systems are operating adequately. Erosion and sediment control BMPs shall be maintained and functional for the entire duration of the project.

7. Ingress and egress vehicle access points onto disturbed areas shall be stabilized with Vehicle Tracking Control Pads (VTC) and shall be constructed with angular rock, 3" to 6" in size and to a depth of at least 9-inches. The use of recycled asphalt or concrete is not permitted. The VTC shall be installed over a liner of non-woven geotextile with a weight of at least 10 oz/yd² and a grab tensile strength of at least 250 pounds. No dirt or other materials shall be placed on paved surfaces or curb flow lines to act as curb ramps. Only metal ramps or rock wattles may be used in the curb flow line.

8. Fugitive dust emissions resulting from grading activities and/or wind shall be controlled using reasonably available control technology as defined by the Colorado Department of Public Health and Environment.

9. All potential pollution sources on-site shall be identified and control measures installed and practiced to minimize the likelihood of a release. Spill prevention controls shall be developed for the site with BMPs in place to respond to any spills, leaks or other releases.

10. Hydraulic mulching as a means to cover and protect seeding is not an acceptable means of applying mulch in the City of Aurora unless a previously installed irrigation system is used to aid germination and growth and where approved through variance. Hydraulic seeding is not permitted.

11. For all porous landscape detention facilities, in order to prevent clogging of filter medium, installation of the filtration system must be delayed until after the site is fully landscaped.

12. If stockpiles are located within 100 feet of a drainageway or a public storm sewer system, additional sediment controls such as temporary diversion dikes, silt fence, or sediment basin shall be required.

Page Intentionally Left Blank

SECTION 1 SITE DESCRIPTION

In this section, the preparer can gather some basic site information that will be helpful to the permittee later when you file for permit coverage.

- For more information, see City of Aurora *Rules and Regulations Regarding Stormwater Discharges Associated with Construction Activities, current revision* (also known as the *SWMP Manual*), Chapter 2
- Detailed information on determining your site's latitude and longitude can be found at www.epa.gov/npdes/stormwater/latlong

i Site Location

- Site location including, Section, township, range, and latitude/longitude to the nearest 15 seconds.
- Project street location or nearest major cross streets
- If applicable, specific acknowledgement that the land is currently, or will ultimately be owned or managed by the Parks, Recreation and Open Space Department.

Project/Site Name: _____	
Project Street/Location: _____	
City: _____	State: ____ ZIP Code: _____
County or Similar Subdivision: _____	
Latitude/Longitude (Use one of three possible formats, and specify method)	
Latitude:	Longitude:
1. ____° ____' ____" N (degrees, minutes, seconds)	1. ____° ____' ____" W (degrees, minutes, seconds)
2. ____° ____' ____" N (degrees, minutes, decimal)	2. ____° ____' ____" W (degrees, minutes, decimal)
3. ____° N (decimal)	3. ____° W (decimal)
Method for determining latitude/longitude:	
<input type="checkbox"/> USGS topographic map (specify scale: _____)	<input type="checkbox"/> EPA Web site <input type="checkbox"/> GPS
<input type="checkbox"/> Other (please specify): _____	

Is this land currently or will it ultimately be owned or managed by COA Parks, Recreation, and Open Space Department? Yes No

CDPS Permit #*: _____

COA SWQ Permit #*: _____

**(This is the unique identifying number assigned to your project by your permitting authority after you have applied for coverage under the appropriate construction permit.)*

ii Description of Adjacent Areas

- Provide a description of adjacent areas such as residential areas, roads, streams, lakes, etc, which might be affected by the proposed project’s land disturbing activity.

Provide adjacent area information

INSERT TEXT HERE

a) Nature and Purpose of Construction Activity

Describe of the nature and purpose of the construction activity, note any vertical construction.

INSERT TEXT HERE

- Residential
 Commercial
 Industrial
 Road Construction
 Linear Utility
 Overlot Grading
 Over-excavation
 Vertical Construction
 Other (please specify): [INSERT TEXT HERE](#)

b) Construction Sequence

The proposed sequence for major activities should be described, including:

- An estimated project start
- An estimated project end date
- The sequence of major construction activities (Initial, interim, final or overlot grading, utilities, vertical, paving, over – excavation, etc.). This is expected to be a brief overview of the project as more detailed phasing information and specific BMPs will be addressed in later sections of the SWMP narrative report.

Estimated Project Start Date: / /

Estimated Project Completion Date: / /

Describe the major phases of construction:

INSERT TEXT HERE

c) Area

The areas for the site should be described including any grading phasing which will need all of the information by phase, as well as for the overall project. This also includes overlot grading in

different phases to achieve the outcome of the project. This may be required to be modified by the contractor with a phasing plan submittal.

- Provide estimates of the total area of the site and the sub area within the site expected to undergo clearing, excavation or grading.
- Include an estimate of the excavation and fill volumes involved during the proposed construction.
- Include an estimate of how excavation and fill will be phased.
- Include an estimate of over-excavation areas and volumes (and type) and an estimate of offsite trucking volume (import and/or export).

Note: If exporting material to an area within the COA limits, the receiving site must have its own SWMP and may be required to have its own COA Stormwater Quality Discharge Permit. If the export site is outside of COA limits, then the requirements of that local jurisdiction must be met and proof of a valid permit for the site will be required.

Total project area:			acres	
Construction site area to be disturbed:			acres	
Construction site over excavation area to be disturbed:			acres	
Export/Import Volume				
Phase Area		Cut/Fill	Net	

Description of phasing for sites disturbing more than 40 acres.:

[INSERT TEXT HERE](#)

d) Topography, Soils, and Rainfall Data

- Provide a summary describing the soil, the soil type, and hydrologic soil group, permeability, texture, soil erosion potential, depth, soil structure, etc. and potential impacts of the soil type on the quality of any stormwater discharge from the site.

- A description of the topography of the site, existing site conditions, drainage patterns, and existing site slopes should also be included.

Note: A soils map showing the site limits and excerpts regarding the soils information shall be placed in the SWMP narrative report appendices.

Soil type(s):

INSERT TEXT HERE

Description	Result	Location of Occurrence
Highest Elevation:		
Lowest Elevation:		
Steepest Slope:		
Average Slope:		

Slopes (describe current slopes and note any changes due to grading or fill activities):

INSERT TEXT HERE

Drainage Patterns (describe current drainage patterns and note any changes dues to grading or fill activities):

INSERT TEXT HERE

Normal Monthly Precipitation Table in Inches

Jan	Feb	Mar	Apr	May	Jun	Jul	Aug	Sep	Oct	Nov	Dev
0.51	0.49	1.28	1.93	2.32	1.56	2.16	1.82	1.14	0.99	0.98	0.63

Adapted from: <http://www.ncdc.noaa.gov/oa/climate/online/ccd/nrmlprcp.html>

Imperviousness and Runoff Coefficients:

- Calculate the percentage of impervious surface area before and after construction
- Calculate the runoff coefficients before and after construction.

Percentage impervious area before construction:			%
Runoff coefficient before construction :			
Percentage impervious area after construction:			%
Runoff coefficient after construction:			

e) Existing Vegetation

- Provide a description of the existing vegetation at the site and an estimate of the percent vegetative cover density prior to disturbance in an average square yard of the site. This requirement does not encompass hard surfaces or damaged areas. The consultant may have to evaluate vegetation from a nearby area if there has already been disturbance.
- A plan showing the existing major trees (4" diameter trunks and larger), tree masses, and shrub masses should be provided.

Existing Vegetation on the site:

INSERT TEXT HERE

Pre-disturbance vegetation density:

INSERT TEXT HERE

Discuss tree protections:

INSERT TEXT HERE

f) Potential Sources of Pollution

- Identify and list the proposed location and description of any potential pollution sources anticipated to be used during the project, such as portable toilets, vehicle fueling, grout/cement mixers, storage of fertilizers, paints or chemicals and stockpiles, etc.
- Materials of concern may include, but are not limited to, raw materials, fuels, metallic products, hazardous substances designated under Section 101(14) of the Comprehensive Environmental Response, Compensation, and Liability Act (CERCLA), any chemical the facility is required to report pursuant to Section 313 of title III of the Superfund Amendments and Reauthorization Act (SARA), fertilizers, pesticides, ash, slag, sludge concrete washout, paints, solvents, and waste piles.

Note: This is expected to be a brief list with detailed information being addressed in later sections of the SWMP narrative report.

Potential pollutants and sources to stormwater runoff:

INSERT TEXT OR USE TABLE BELOW

Trade Name, Material, or Operation	Stormwater Pollutants	Potential Location
Bedding Stockpiles	Sediment	Entire site
Boring Operations, Concrete Cutting Operations or Other Operations that Water Use	Sediment, slurry, concrete fines, processed water, etc	Bore sites, site perimeters, pothole locations, etc
Carpentry and Framing	wood, solvents, stains, debris	Building Construction

<i>Trade Name, Material, or Operation</i>	<i>Stormwater Pollutants</i>	<i>Potential Location</i>
Concrete Materials and Concrete Waste Management	Concrete	Entire site
Concrete Curing	Curing Compound	Areas of Concrete Construction
Demolition and Debris Disposal	Trash, Sediment, various other contaminants	Existing Building Areas
Dewatering and Poned Water Management	Ground Water and Poned Water containing various other pollutants	Entire site
Form Oil and Concrete Forms	Form Oil	Building Construction
Generators	Oil, Gasoline, etc	Entire site
Grading Operations (clearing, excavating, etc)	Sediment	Entire Site
Hazardous Wastes	Fire Retardant, Acid Wash, Graffiti Prevention Liquid, Processed Water	Building Construction
HVAC	Debris, Glue, etc	Building Construction
Insulation	Fiberglass, other debris	Building Construction
Landscape Products	Fertilizers, Herbicides, pesticides, fungicides, etc.	Entire site
Masonry	Cement, Grout, Masonry Mixers, Sand Stockpiles, etc	Building Construction
Material Delivery	Other Materials	Entire site
Painters	Paint, Primers, Stains, Glue	Building Construction
Paving Operations	Asphalt, Tar, Road Base, Lime	Roadways and Parking areas
Plumbing	Trash, Glue, Solder	Building Construction
Processed Water	Any number of chemicals or other toxins	Entire site
Roofing	Asphalt, Wood, Concrete	Building Construction
Sanitary Waste Management	Sanitary Waste	Building Construction and Staging Areas
Soil Stockpiling	Sediment	Entire site
Stabilized Staging/Haul Routes	Sediment, Fuel, Oil	Entire site
Stucco, Plastering, Drywalling	Drywall, Plaster, Tool Cleaning, etc	Building Construction
Trash	Debris, Bacteria, various chemicals, etc.	Building Construction and Staging Areas
Utility Excavations	Sediment, Fuel, Oil	Entire site
Vehicle and Equipment Maintenance, Cleaning, or Leaks	Fuel, Oil, Grease, Chemicals, Hydraulic Oil	Entire site

g) Non Stormwater Discharges

Identify and list the location and description of any anticipated non-stormwater components of the discharge, such as springs (State permit required), potable water for dust suppression, landscape irrigation return flow, pipeline dewatering (i.e. waterline flushing and testing) diverted stream flows, flows from wetlands, firefighting activities, hydrant blow-offs, building power-washing where detergents are not used, construction dewatering of groundwater (State permit required), uncontaminated air conditioning or compressor condensate, foundation or footing drains where flows are not contaminated with process materials such as solvents (State permit may be required), or other discharges specifically authorized by a separate National Pollutant Discharge Elimination Systems (NPDES) permit or a separate Colorado Discharge Permit System (CDPS) permit etc.

- Identify all allowable sources of non-stormwater discharges that are not identified. The allowable non-stormwater discharges identified might include those in the table below.
- Identify measures used to eliminate or reduce these discharges and the BMPs used to prevent those discharges from becoming contaminated.

Check if Applicable to Site	List of Potential Non-Stormwater Discharges	Management of Discharge
<input type="checkbox"/>	Waters used to wash vehicles where detergents are not used	
<input type="checkbox"/>	Water used to control dust	
<input type="checkbox"/>	Potable water including uncontaminated water line flushings	
<input type="checkbox"/>	Routine external building wash down that does not use detergents	
<input type="checkbox"/>	Pavement wash waters where spills or leaks of toxic or hazardous materials have not occurred (unless all spilled material has been removed) and where detergents are not used	
<input type="checkbox"/>	Uncontaminated air conditioning or compressor condensate	
<input type="checkbox"/>	Uncontaminated ground water or spring water	
<input type="checkbox"/>	Foundation or footing drains where flows are not contaminated with process materials such as solvents	
<input type="checkbox"/>	Uncontaminated excavation dewatering	
<input type="checkbox"/>	Landscape irrigation	
<input type="checkbox"/>	Potable water for firefighting activities	
<input type="checkbox"/>	Diverted channels or streams	

Check if Applicable to Site	List of Potential Non-Stormwater Discharges	Management of Discharge
<input type="checkbox"/>	Flows from wetlands	
<input type="checkbox"/>	Sanitary sewer/plumbing line testing	
<input type="checkbox"/>		

h) Receiving Waters

List the name of all potential receiving water (s) and the size, type and location of any outfall. If the discharge is to a municipal storm sewer system, then provide the name of that system, the location of the storm sewer discharge, and the ultimate receiving water(s). State whether or not there are wetlands, the 100-year floodplain status (i.e. if the site is within a floodway, near a flood plain or not within a flood zone), if the receiving water is impaired or not, and if there are any stream crossings proposed.

Note: Floodplain maps shall be provided in the SWMP narrative report appendices and shall show the site in relation to the floodplain.

- List the waterbody(s) that would receive stormwater from your site, including streams, rivers, lakes, and wetlands. Describe each as clearly as possible, such as *Murphy Creek, a tributary to the Sand Creek*, and so on.
- Indicate the location of all waters, including wetlands, on the site map.
- Note any stream crossings or stream diversions, if applicable.
- List the downstream storm inlets, storm sewer system or drainage system that stormwater from your site could discharge to and the waterbody(s) that it ultimately discharges to.
- If any of the waterbodies above are impaired and/or subject to Total Maximum Daily Loads (TMDLs), please list the pollutants causing the impairment and any specific requirements in the TMDL(s) that are applicable to construction sites. Your SWMP should specifically include measures to prevent the discharge of these pollutants.

The site is within the Cherry Creek Drainage Basin: Yes No

The site is within the Aurora Reservoir Drainage Basin: Yes No

Description of receiving waters:

INSERT TEXT HERE

Description of storm inlets and storm sewer systems:

INSERT TEXT HERE

Description of impaired waters or waters subject to TMDLs:

INSERT TEXT HERE

100- Year Floodplain Status:

INSERT TEXT HERE

Description of wetlands:

INSERT TEXT HERE

Other: INSERT TEXT HERE

i) Site Features and Sensitive Areas to be Protected

- Describe unique site features including streams, stream buffers, wetlands, specimen trees, natural vegetation, steep slopes, or highly erodible soils that are to be preserved.
- Describe measures to protect these features.
- Include these features and areas on your SWMP design drawings.

INSERT TEXT HERE

j) Other Applicable Federal, State or Local Programs, Regulations or Restrictions

State any other regulations that are affecting the site (i.e. Regulation 72, Consent Decrees, etc).

INSERT TEXT HERE

1) Endangered Species Certification

State whether or not there are any endangered species or critical habitats on or near the site. If so, then describe the impacts and the measures being taken to address that impact and supply documentation in the SWMP narrative report appendices.

Are endangered or threatened species and critical habitats on or near the project area?

Yes No

If yes, describe the species and/or critical habitat and provide reference to other documents as appropriate:

INSERT TEXT HERE

2) Historic Preservation

State whether or not there are any historic sites on or near the site. If so, then describe the impacts and the BMP measures being taken to address that impact

Are there any historic sites on or near the construction site?

Yes No

If yes, describe or refer to documentation that determines the likelihood of an impact on this historic site and the steps taken to address that impact.

[INSERT TEXT HERE](#)

SECTION 2 DESIGN DRAWINGS

Approved design drawings shall be kept with the approved narrative report (this document) in the field and must be kept current. See COA SWMP Manual Chapter 3 for more information regarding Living Documents. For most projects, a series of site maps is recommended. The first should show the undeveloped site and its current features. An additional map or maps should be created to show the developed site or for more complicated sites show the major phases of development.

- SWMP design drawings are required to indicate the types, locations, and extents of BMPs proposed for installation on the project site.
- For more information and requirements, see *Rules and Regulations Regarding Stormwater Discharges Associated with Construction Activities, current revision* (also known as the *SWMP Manual*), Chapter 2

SECTION 3 STORMWATER MANAGEMENT CONTROLS

This section shall describe the stormwater management controls that will be used to control pollutants in stormwater discharge during construction activity.

a) **SWMP Administrator and Important Contacts**

- List Contact names and phone numbers for the SWMP Administrator, alternates, owner, developer, etc
- Copy as needed

Owner/Operator(s):
Company or Organization Name:
Name:
Address:
City, State, Zip Code:
Telephone Number:
Fax/Email:
Area of Control (if more than 1 operator at site):

Project Manager(s) or Site Supervisor(s):
Company or Organization Name:
Name:
Address:
City, State, Zip Code:
Telephone Number:
Fax/Email:
Area of Control (if more than 1 operator at site):

SWMP Administrator Contact(s):
Company or Organization Name:
Name:
Address:
City, State, Zip Code:
Telephone Number:
Fax/Email:
Area of Control (if more than 1 operator at site):

This SWMP was Prepared by (the Colorado Licensed Engineer):
Company or Organization Name:
Name:
Address:
City, State, Zip Code:
Telephone Number:
Fax/Email:

Emergency 24-Hour Contact:
Company or Organization Name:
Name:
Address:
City, State, Zip Code:
Telephone Number:
Fax/Email:
Area of Control (if more than 1 operator at site):

Subcontractor(s):

Company or Organization Name:
Name:
Address:
City, State, Zip Code:
Telephone Number:
Fax/Email:
Area of Control (if more than 1 operator at site):

Other:
Company or Organization Name:
Name:
Address:
City, State, Zip Code:
Telephone Number:
Fax/Email:
Area of Control (if more than 1 operator at site):

Other:
Company or Organization Name:
Name:
Address:
City, State, Zip Code:
Telephone Number:
Fax/Email:
Area of Control (if more than 1 operator at site):

b) Identification of Potential Pollutant Sources

All potential pollutant sources, including materials and activities, at a site must be evaluated for the potential to contribute pollutants to stormwater discharges.

- Identify and describe the sources of potential pollutants to stormwater discharges. At a minimum, each of the following sources and activities shall be evaluated for the potential to contribute pollutants to stormwater discharges.
- Numbers in [] brackets indicate the appropriate section to describe the BMPs to be used to address the potential pollutant source

Applicable to Site (Y, N, Maybe)	Sources of Potential Pollutants to Stormwater Discharges		Applicable to Site (Y, N, Maybe)	Sources of Potential Pollutants to Stormwater Discharges
	All disturbed and stored soils (including borrow areas, stockpiles, haul routes, and over-excavation) [Section 3 c) 1, 2, and 3]			Routine maintenance activities involving fertilizers, pesticides, detergents, fuels, solvents, oils, etc. [Section 3 c) 4]
	Vehicle tracking controls and clean up [Section 3 c) 6]			On-site waste management practices (waste piles, liquid wastes, dumpsters, etc.) [Section 3 c) 7]
	Management of contaminated soils [Section 3 c) 4]			Concrete truck/equipment washing, including the concrete truck chute, pump truck primary and associated fixtures and equipment [Section 3 c) 7]
	Loading and unloading operations (including access points and protection of existing BMPs) [Section 3 c) 10]			Dedicated asphalt and concrete batch plants [Section 3 c) 5]
	Outdoor storage areas (building materials, fertilizers, chemicals, etc.) [Section 3 c) 4]			Non-industrial waste sources such as worker trash and portable toilets [Section 3 c)7]
	Vehicle and equipment maintenance and fueling [Section 3 c) 4]			Other areas or procedures where potential spills can occur [Section 3 c) 4]
	Significant dust or particulate generating processes (including haul routes, masonry mixing, and silos)			Stormwater or groundwater dewatering [Section 3 c) 9]

Applicable to Site (Y, N, Maybe)	Sources of Potential Pollutants to Stormwater Discharges		Applicable to Site (Y, N, Maybe)	Sources of Potential Pollutants to Stormwater Discharges
	[Section 3 c) 2]			
	Power washing of building using detergents or other chemicals/solvents [Section 3 c) 4]			
	Building/vertical construction (including paints, solvents, drywall, fire retardant, etc) [Section 3 c) 4, 7, 10]			

c) **BMPs for Stormwater Pollution Prevention**

This section of the SWMP narrative report shall include a narrative description of the appropriate controls and measures that will be implemented before, during and after construction activities at the project site to manage and control the runoff of pollutants.

The SWMP narrative report shall clearly describe the relationship between the phases of construction, and the implementation and maintenance of BMP controls and measures. For example, the report must indicate which controls will be implemented during each of the following phases of construction: clearing and grubbing for perimeter controls, installation of initial BMPs, clearing and grubbing, overlot grading, installation of interim BMPs, site construction, utility construction, vertical construction, other pertinent construction phases, final grading, stabilization, removal of BMPs, and Permit closeout.

1) Structural Practices

- Clearly describe the initial/interim, post-paving, and permanent structural site management practices to control erosion and sediment transport. Practices may include, but are not limited to: silt fences, diversion dikes, sediment traps, sediment basins, temporary slope drains, inlet protection, outlet protection, check dams, curb/rock socks, vehicle tracking control pads, sediment control logs, compacted earthen berm, and terracing.

<i>BMP Description:</i>	
<i>Intended Use/Purpose:</i>	
<i>Appropriate Installation Timing:</i>	
<i>Appropriate Removal Timing:</i>	

Repeat as needed

2) Non-Structural Practices

- Clearly describe initial/interim, post-paving, and permanent stabilization practices, including site specific scheduling of the implementation of these practices. Site plans should ensure that existing vegetation is preserved where possible and that all disturbed areas are stabilized. Non-structural practices may include, but are not limited to: temporary seeding, permanent seeding, mulching, sod stabilization, vegetative buffer strips, tree protection, landscaping, erosion control blankets/matting, soil retention matting, surface roughening, dust suppression, street sweeping (required weekly at a minimum), seasonal schedule, and preservation of mature vegetation.

<i>BMP Description:</i>	
<i>Intended Use/Purpose:</i>	
<i>Appropriate Installation Timing:</i>	
<i>Appropriate Removal Timing:</i>	

Repeat as needed

3) Phase Construction Activity and BMP Implementation

This section shall describe the relationship between the phases of construction, and the implementation and maintenance of BMP controls and measures. For example, indicate which controls will be implemented during each of the following phases of construction: prior to clearing and grubbing for perimeter controls (installation of initial BMPs), clearing and grubbing, overlot grading, installation of interim BMPs, site construction, utility construction, vertical construction, other pertinent construction phases, final grading, stabilization, removal of BMPs, and Permit closeout.

- Clearly describe the various phases of construction and the implementation of BMPs to be used during each phase. Examples of project phases may include, but are not limited to, demolition, clearing and grubbing, overlot grading, over-excavation, road construction, utility installations, vertical construction, fine grading, and final stabilization. The description for a particular phase may have sub-phases. For example, the overlot grading of an 80 acre site may have to describe multiple sub-phases for the 40 acre disturbance limitation. Another example would be vertical construction phase may describe sub-phases of the construction such as grading, foundations, framing, finishing, and stabilization. For more information, see *SWMP Manual*, Chapter 2, Section 2.2.1)

Note: Some construction information may need to be added once a contractor(s) are involved. See the Manual and below for more information.

<i>Phase Description:</i>	
<i>Duration of phase (start/end dates):</i>	
<i>BMPs Associated with the Phase:</i>	
<i>Describe Temp/Final Stabilization for Phase:</i>	

Repeat as needed

a. Overlot Grading Specific Practices

Overlot grading specific practices should address items such as: surface roughening, blanketing, terracing, mulching, temporary seeding, permanent seeding, temporary sediment pond construction and removal, phasing, haul routes, disturbance limits, rough cut street controls, etc.

- Address haul routes may be designated on the SWMP updates and shall take into consideration drainage, erosion and sediment control BMPs, along with interim stabilization measures.

<i>BMP Description:</i>	
<i>Intended Use/Purpose:</i>	
<i>Appropriate Installation Timing:</i>	
<i>Appropriate Removal Timing:</i>	

Repeat as needed

- Discuss interim stabilization may be provided via plan amendment by the contractor and the engineer at the Erosion Control Kick Off meeting. These measures shall be provided with timeframes and down gradient controls.

<i>BMP Description:</i>	
<i>Intended Use/Purpose:</i>	
<i>Appropriate Installation Timing:</i>	
<i>Appropriate Removal Timing:</i>	

Repeat as needed

Temporary drainage BMPs (diversion ditches, sediment traps or sediment basins) shall be maintained at all times.

- Discuss timing and procedural requirements for implementation, maintenance and removal of these items during this period of construction.

<i>BMP Description:</i>	
<i>Intended Use/Purpose:</i>	
<i>Appropriate Installation Timing:</i>	
<i>Appropriate Removal Timing:</i>	

Repeat as needed

- b. Vertical Construction Requirements – See Appendix for Table of Required Information

- Staging areas change during construction regularly. Therefore, if “con/conex” boxes are to be utilized and if they are to include liquid pollutants, then a redundant BMP measure must be provided
- Site drainage will need to be maintained during vertical construction. Review conditions to ensure that it will continue to work as shown during the grading/utility timeframes.
- Provide redundant BMPs for generators and mobile concrete washouts to protect from fuel/hydraulic leaks
- Continuously review the down gradient BMPs within the impervious and disturbed areas to ensure that conveyances, inlets and outlets are protected appropriately during this phase.
- Areas of disturbance outside of the building envelope shall still require BMPs.
- Continuously review the timing/phasing of the project to ensure the appropriate BMPs are implemented as construction continues. Deletion of BMPs shall require different measures to be implemented upon deletion.
- BMPs for keeping impervious surfaces clean may need to be enhanced or added to as construction continues.
- Review and implement BMP measures to control roof drainage. This becomes a point source and may cause extensive erosion on site.

Optional Section – To be included if the items in bullet points cannot be addressed with this report.

A Plan Amendment from the contractor shall be required to be submitted to the engineer of record and City of Aurora Water Engineering Plans Reviewer three (3) business days prior to the Erosion Control Kick-Off Meeting. This submittal shall provide narrative information and the associated details required for vertical construction BMPs (structural and non-structural) that will be implemented during this phase of construction.

- Provide a mixing station detail/area for masonry/brick. If the site is going to bring in silos for masonry mixing, wind protection will be required to minimize the maximum extent practicable the dust from impacting adjacent buildings and streets.
- Saw cutting station detail/area
- Options for handling paints, solvents, glues (i.e. utilize the CWS or provide alternative)
- Provide physical and procedural BMPs for clean up along the building during the installation of brick, stone or stucco
- Access may be required around the building, defining a haul route may be necessary and denote stabilization needs on this proposed haul route
- Address waste handling procedures for drywall, painters, carpet layers etc.

- Stream Diversion Method
- Cranes when access is required around the building and may impact BMPs, relocation may be required

4) Material Handling and Spill Prevention

This section shall describe any procedures and locations for all practices implemented at the site that will be used to minimize impacts from identified potential pollutant sources. BMPs need to address many different pollutant sources that include, but are not limited to exposed storage of construction materials, liquid contaminants, contaminated soils management, fueling procedures, redundant measures for any spill or leak sources, and equipment maintenance procedures. Activities involving potential for spills shall have spill prevention and spill response procedures identified.

- Identify and describe how the sources of potential pollutants to stormwater discharges identified in Section 3.2 will be controlled through BMP selection and implementation. The information provided may address frequency, seasonal considerations, characteristics of the area and surface type, primary and secondary containment, proximity to drainageways and stormwater facilities.

<i>BMP Description:</i>	
<i>Intended Use/Purpose:</i>	
<i>Location(s)</i>	

Repeat as needed

BMP Description: SPILL RESPONSE -Cleanup and Removal Procedures

NOTE: IN CASE OF FIRE, EVACUATE ALL PERSONNEL FROM THE IMMEDIATE AREA, RENDER FIRST AID TO ANYONE WHO IS INJURED, AND DIAL 911 IMMEDIATELY. TAKE APPROPRIATE STEPS TO PROTECT HUMAN LIFE AND TO CONTROL FIRES FIRST. SPILL CONTROL IS SECONDARY.

- Upon detection of any spill, the first action to be taken is to ensure personal safety. All possible ignition sources, including running engines, electrical equipment (including cellular telephones, etc.), or other hazards will be immediately turned off or removed from the area. The extent of the spill and the nature of the spilled material will be evaluated to determine if remedial actions could result in any health hazards, escalation of the spill, or further damage that would intensify the problem. If such

conditions exist, a designated employee will oversee the area of the spill and the construction SWMP Administrator will be notified immediately.

- The source of the spill will be identified and if possible the flow of pollutants stopped if it can be done safely. However, no one should attend to the source or begin cleanup of the spill until **ALL** emergency priorities (fire, injuries, etc.) have been addressed.

Small Spills

Small spills (usually <5 gallons) consist of minor quantities of gasoline, oil, anti-freeze, or other materials that can be cleaned up by a single employee using readily available materials.

The following procedures should be used for clean-up of small spills:

- a. Ensure personal safety, evaluate the spill, and if possible, stop the flow of pollutants.
- b. Contain the spread of the spill using absorbents, portable berms, sandbags, or other available measures.
- c. Spread absorbent materials on the area to soak up as much of the liquid as possible and to prevent infiltration into the soil.
- d. Once the liquids have been absorbed, remove all absorbents from the spill and place the materials in a suitable storage container. On paved areas, wipe any remaining liquids from the surface and place the materials in a storage container. Do not spray or wash down the area using water. For open soil areas, excavate any contaminated soil as soon as possible and place the soil in a suitable storage container. All materials will then be transported off-site for disposal.
- e. If immediate transfer and storage of the contaminated soil is not practical, excavate and place the contaminated soil on a double thickness sheet of 3-mil or higher polyethylene film. In addition, a small berm should be formed around the outer edges of the soil stockpile, underneath the polyethylene film, to ensure that contaminants are not washed from the site during precipitation events and that materials do not seep through the berm.
- f. Record all significant facts and information about the spill, including the following:
 - Type of pollutant
 - Location
 - Apparent source
 - Estimated volume
 - Time of discovery
 - Actions taken to clean up spill
- g. Notify the SWMP Administrator of the spill and provide the information from Item #6. The SWMP Administrator will then contact the City of Aurora Erosion Control Staff.

Medium to Large Spills

Medium to large spills consist of larger quantities of materials (usually >5 – 25 gallons) that are used on site that cannot be controlled by a single employee. Generally, a number of facility personnel will be needed to control the spill and a response may require the suspension of other facility activities.

The following procedure shall be used for the cleanup of medium to large spills:

- a. Ensure personal safety, evaluate the spill, and if possible, stop the flow of pollutants.
- b. Immediately dispatch a front-end loader or similar equipment to the spill and construct a berm or berms down gradient of the spill to minimize the spread of potential pollutants. On paved surfaces, portable berms, sandbags, booms, or other measures will be used to control the lateral spread of the pollutants.
- c. When the spread of the spill has been laterally contained, contact the SWMP Administrator or designated facility employee and provide them information on the location, type, and amount of spilled material, and a briefing on the extent of the spread and measures undertaken to contain the contaminants.
- d. Depending on the nature of the spill, mobilize additional resources as needed to contain the contaminants.
- e. Cleanup will commence when the lateral spread has been contained and the notification to the SWMP Administrator has been made.
- f. Freestanding liquid will be bailed or pumped into 55-gallon storage drums, steel tanks, or other suitable storage containers. When all the liquid has been removed from the pavement or soil layer, absorbents will be applied to the surface and transferred to the storage containers when they have soaked up as much of the spill as possible.
- g. On paved surfaces, the remaining contaminants will be removed to the extent possible, with rags, sweeping, or similar measures. The area of the spill will not be sprayed or washed down using water. Any contaminant soaked materials will be placed into the storage containers with the other absorbents.
- h. The remaining contaminated soils will be excavated and loaded into a dump truck(s) for disposal off-site at a designated facility. If transport off-site is not immediately available, the remaining soils will be stockpiled on a double thickness sheet of 3-mil or higher polyethylene film. In addition, a small berm will be formed around the outer edges of the soil stockpile, underneath the polyethylene film, to ensure that contaminants are not washed from the site during precipitation and do not seep through the berm.
- i. Record all significant facts and information about the spill, including the following:
 - Type of pollutant
 - Location
 - Apparent source
 - Estimated volume
 - Time of discovery

- Actions taken to clean up spill
- j. Provide the SWMP Administrator (or designated employee) with the information from Item #9. The SWMP Administrator will then contact the City of Aurora Flow Control Center.

NOTIFICATION

Notification to the Colorado Department of Public Health & Environment (CDPHE) and the City of Aurora is required if there is any release or suspected release of any substance, including oil or other substances that spill into or threaten State waters. Unless otherwise noted, notifications are to be made by the SWMP Administrator and only after emergency responses related to the release have been implemented. This will prevent misinformation and assures that notifications are properly conducted.

The notification requirements are as follows:

1. **Spills into/or Threatens State Waters:** Immediate notification is required for releases that occur beneath the surface of the land or impact or threaten waters of the State of threaten the public health and welfare. Notifications that will be made are:
 - a. For any substance, regardless of quantity, contact CDPHE at 1-877-518-5608. State as follows:
 - a) Give your name.
 - b) Give location of spill (name of city).
 - c) Describe the nature of the spill, type of products, and estimate size of spill.
 - d) Describe type of action taken thus far, type of assistance or equipment needed.
 - b. For any quantity of oil or other fluids, call the National Response Center at 1-800-424-8802. State as follows:
 - a) Give your name.
 - b) Give location of spill (name of city and state).
 - c) Describe the nature of the spill, type of product, and estimate size of spill.
 - d) Describe type of action taken thus far, type of assistance or equipment needed.

2. **Reportable Quantity Spill on Land Surface:** Immediate notification is required of a release upon the land surface of an oil in quantity that exceeds 25 gallons, or of a hazardous substance that equals or exceeds 10 pounds or its reportable quantity under Section 101(14) of the Comprehensive Environmental Response, Compensation Liability Act (CERCLA) of 1980 as amended (40 CFR Part 302) and Section 329 (3) of the Emergency Planning and Community Right to Know Act of 1986 (40 CFR Part 355) whichever is less. This requirement does apply at a minimum to the substances listed in Table A below.

TABLE A

Substances Requiring Notification

SUBSTANCE	REPORTABLE QUANTITY
-----------	---------------------

Motor Oil	25 Gallons
Hydraulic Oil	25 Gallons
Gasoline/Diesel Fuel	25 Gallons

The notification procedures to be followed are:

- a) Give your name.
 - b) Give location of spill (name of city and state).
 - c) Describe nature of the spill, type of product, and estimate size of spill.
 - d) Describe type of action taken thus far, type of assistance or equipment needed.
3. Notification is not required for release of oil upon the land surface of 25 gallons or less that will not constitute a threat to public health and welfare, the environmental or a threat of entering the waters of the State.
 4. Notification, as required in paragraphs 1 and 2 above, will be made to the CDPHE using the 24-hour telephone number to report environmental spills. All information known about the release at the time of discovery is to be included, such as the time of occurrence, quantity and type of material, location and any corrective or clean-up actions presently being taken. Table B lists these phone numbers.

SPILL RESPONSE CONTACTS

TABLE B

Emergency Notification Contacts

Name/Agency	Number
City of Aurora Fire Department	911
City of Aurora Police Department	911
Ambulance	911
Hospital	911
National Response Center	1-800-424-8802
CDPHE – Report Environmental Spills (24 hrs/day)	1-877-518-5608
City of Aurora – Water Dept Erosion Control Staff	303-326-8645
Colorado Emergency Planning Committee	303-273-1622
Also contact SWMP Administrator and Owner	

It is the responsibility of the SWMP Administrator to contact the City of Aurora, CDPHE, and/or the National Response Center.

- **The National Response Center** is to be contacted when a release containing a hazardous substance or oil in an amount equal to or in excess of a reportable quantity established under either 40 CFR 110, 4- DFR 117, or 40 CFR 302 occurs during a 24-hour period.

- Notification to the **CDPHE** and **COA** is required if there is any release or suspected release of any material, including oil or hazardous substances that spill into or threaten state waters.

REPORTS

The CDPHE and COA require written notification of a spill or discharge of oil or other substance that may cause pollution of the waters of the State of Colorado. A written report must be submitted to the Water Quality Control District (WQCD) and the COA Erosion Control Staff within five days after becoming aware of the spill or discharge.

The CDPHE and COA require a written final report within 15 days for all releases of an oil or hazardous substance that require implementation of a contingency plan. The CDPHE and COA may also require additional reports on the status of the clean up until any required remedial action has been complete.

Written notification of reports must contain at a minimum:

1. Date, time, and duration of the release.
2. Location of the release.
3. Person or persons causing and responsible for the release.
4. Type and amount of oil or substance released.
5. Cause of the release.
6. Environmental damage caused by the release.
7. Actions taken to respond, contain, and clean up the release.
8. Location and method of ultimate disposal of the oil or other fluids.
9. Actions taken to prevent a reoccurrence of the release.
10. Any known or anticipated acute or chronic health risks associated with the release.
11. When appropriate advice regarding medical attention necessary for exposed individuals.

5) Dedicated Concrete or Asphalt Batch Plants

- Describe measures to control stormwater pollution from dedicated concrete batch plants or dedicated asphalt batch plants covered by the SWMP.

<i>BMP Description:</i>	
<i>Intended Use/Purpose:</i>	
<i>Appropriate Installation Timing:</i>	
<i>Appropriate Removal Timing:</i>	

[Repeat as needed](#)

6) Vehicle Tracking Control

- Describe all practices implemented at the site to control potential sediment discharges from vehicle tracking. Practices must be implemented for all areas of potential vehicle tracking, and can include: minimizing site access; street sweeping or scraping; tracking pads; stabilized staging and parking areas; requiring that vehicles stay on paved areas on-site; wash racks; contractor education; and/or sediment control BMPs, etc

BMP Description: Mandatory sweeping of all internal and adjacent external paved areas is required on a weekly basis at a minimum. This applies until Initial Close-Out acceptance. At that time it will be on an as needed basis.

<i>BMP Description:</i>	
<i>Location(s):</i>	
<i>Intended Use/Purpose:</i>	
<i>Appropriate Installation Timing:</i>	
<i>Appropriate Removal Timing:</i>	

[Repeat as needed](#)

7) Waste Management and Disposal, Including Concrete Washout

- Clearly describe the practices implemented at the site to control stormwater pollution from all construction site wastes (liquid and solid), including concrete washout activities and liquid waste washouts, dumpsters, worker trash, and portable toilets.

<i>BMP Description:</i>	
<i>Locations</i>	
<i>Appropriate Installation Timing:</i>	
<i>Appropriate Removal Timing:</i>	

[Repeat as needed](#)

8) BMP Specifications

BMP Details for installation and maintenance shall be the City of Aurora Standard Details in Appendix D of the (*City of Aurora Rules and Regulations Regarding Stormwater Discharge Associated with Construction Activities (SWMP Manual)*), latest revision, an approved variance, or an approved plan amendment. All approved variances must be documented in the SWMP. It is understood that not all details in the COA SWMP Manual will be used on this project site, but that all details are available for implementation if unforeseen circumstances warrant their use. Proper procedures must be used to update the living document and get approval as documented in the COA SWMP Manual. All physical BMPs require a detail to show installation and maintenance information. If a detail is not available through the manufacturer, then one must be created by the preparer of this SWMP narrative report.

9) Groundwater and Stormwater Dewatering

- The SWMP shall clearly describe the practices to be implemented at the site to control stormwater pollution from the dewatering of groundwater or stormwater from excavations, wells, etc.
- For any construction dewatering of stormwater from construction areas, describe the BMPs to be used to control additional erosion and transport of sediment.

Note: This City of Aurora Stormwater permit does not authorize dewatering of groundwater. A separate State permit is required for this activity.

BMP Description:	
<i>Intended Use/Purpose:</i>	
<i>Appropriate Installation Timing:</i>	
<i>Appropriate Removal Timing:</i>	

Repeat as needed

10) Developer/Builder Specific Practices

Include a description of standard practices of the company for whom this SWMP is being developed. At a minimum it shall include:

- Standard practices for construction operations during wet weather conditions and winter weather conditions
- Methods used to obtain compliance from sub-contractors (i.e. fines, education, etc)

- Stormwater education policies for educating personnel and subcontractors
- Company Standard Operating Procedures as they relate to stormwater management (as appropriate)
- Describe any standard construction practices that will be used on the site such as material loading and unloading practices, lot controls, lot access etc.

Note: Any practices requiring a variance that are discussed here must reference the variance section, and must be requested in the variance section, or they will be considered unapproved and not allowed.

<i>BMP Description:</i>	
<i>Intended Use/Purpose:</i>	
<i>Appropriate Installation Timing:</i>	
<i>Appropriate Removal Timing:</i>	

Repeat as needed

[Additional Developer/Builder practices not listed herein shall be submitted 3 days prior to the Erosion Control kick-off meeting for review and approval.](#)

SECTION 4 FINAL STABILIZATION AND LONG TERM STORMWATER MANAGEMENT

a) Final Stabilization Measures

Include a description of the proposed measures to be used to achieve final stabilization and long-term stormwater control. Revegetation with seeding and mulching, revegetation with seeding with erosion control blankets, landscaping, green roofs, permeable paving, permanent water quality ponds and permanent outlet protection are examples of final stabilization measures.

b) Seed Mix Information

Provide the name of the City of Aurora standard seed mix(es) that may be appropriate for the site and the soils anticipated for the site and the preferred method(s) for protecting the seed. If the site is not using a COA standard seed mix, then a variance request must be submitted and the preferred seed mix must be provided with the application rates.

c) Final Stabilization Notes

See Chapter 5 of the Rules and Regulations for more information.

- 1) *Final stabilization is reached when all soil disturbing activities at the site have been completed, and uniform vegetative cover has been established with a density of at least 70% of pre-disturbance levels, or equivalent permanent physical erosion reduction methods have been employed.*
- 2) *Vegetative coverage density does not apply to paved areas, walks, buildings, or other hard surface impermeable areas.*
- 3) *Establishment of a vegetative cover capable of providing the erosion control equivalent to pre-existing conditions at the site can be considered final stabilization (i.e. landscape rocks, mulch, shrubs, etc). This determination will be made by the City of Aurora Water Department Erosion Control Program Staff prior to the close-out of the permit.*

<i>BMP Description:</i>	
<i>Intended Use/Purpose:</i>	
<i>Appropriate Installation Timing:</i>	
<i>Appropriate Removal Timing:</i>	

Repeat as needed

SECTION 5 INSPECTIONS AND MAINTENANCE

This section shall describe procedures to inspect and maintain, in good effective operating condition, the vegetation, erosion, and sediment control measures and all other protective measures identified in the plan.

The following are the required frequencies of inspections:

- i. *Prior to Initial Closeout Acceptance:* Permittee shall self-inspect the site at least every 7 calendar days and within 24-hours after the end of any precipitation event or snowmelt event that results in runoff and causes surface erosion, except as allowed in Item iii below.
 - ii. *Following Initial Closeout Acceptance and until permit closeout:* Permittee shall self-inspect the site at least every 30 calendar days, and within 24-hours after the end of any precipitation event or snowmelt event that results in runoff and causes surface erosion
 - iii. *Post-Precipitation Event Inspections for Temporarily Idle Sites:* If a site is temporarily idle and no construction activities will occur during the 48 hours following a storm event, the post-precipitation event (including snowmelt) inspection shall be conducted prior to commencing construction activities on the site, but no later than 72 hours following the storm event.
- Describe all other procedures necessary to inspect and maintain BMPs on this site.

Note: Do not duplicate information that is provided in the COA Standard Details for Maintenance and Inspection.

BMP Maintenance or Inspection Description:

Repeat as needed

SECTION 6 PROBABLE COST FOR INSTALLATION OF BMPs

The standardized probable cost form shall include costs for required maintenance during the construction phase and shall establish the required Fiscal Security amount.

*Notes: City of Aurora projects do not require Fiscal Security.
The Forms should be located in the Appendix of this SWMP narrative report.*

- List the total cost and the Fiscal Security amount, which is equal to the 25% Maintenance Cost amount of the higher of the two forms.

Initial BMP Total Cost:	\$	
Initial BMP Maintenance Cost:	\$	
Post-Paving BMP Total Cost:	\$	
Post-Paving BMP Maintenance Cost:	\$	
Fiscal Security amount:	\$	

SECTION 7 CALCULATIONS MADE FOR THE DESIGN

Include calculations made in the design of the SWMP, including calculations for sizing of sediment basins, design of erosion control matting, soil retention matting, sediment traps, diversion ditches, temporary stream crossings, weir sizing, or sizing of outlet protection riprap in the appendix with a summary of the results below.

- Address any required additional information below.

INSERT TEXT HERE

SECTION 8 VARIANCE REQUESTS

As may be reasonably required by COA, additional information shall be included here. A listing of variances requested and/or requests for special consideration of innovative BMPs should be provided along with their justification.

Any variance from COA Rules and Regulations Regarding Stormwater Discharges Associated with Construction Activities shall be approved by the City of Aurora. If it is not specifically listed within this section of the narrative, then it shall not be considered an approved variance. There are provisions for Variance requests once construction has begun. See Chapter 3 Section 3.3.3 of the Rules and Regulations. In such cases the City of Aurora approved variance shall be added to the field maintained SWMP.

Note: Manufacturer documentation and specifications for requested variances shall be provided in the appendices. If no detail is provided for a physical BMP, the request for variance will automatically be denied.

- List all Variances being requested

<i>Variance Description:</i>	
<i>Intended Use/Purpose:</i>	
<i>Reason for Variance:</i>	
<i>Maintenance Requirements:</i>	
<i>Appropriate Installation Timing:</i>	
<i>Appropriate Removal Timing:</i>	

Repeat as needed

[Add additional sections here to meet requirements of other regulations]

REFERENCES

References should include the drainage report, the COA SWMP Manual, and the CDPHE permit at a minimum. Other relevant references may be included.

Rules and Regulations Regarding Stormwater Discharges Associated with Construction Activities, current revision

Colorado Department of Public Health and Environment CDPS General Permit – Stormwater Discharges Associated with Construction Activity, current revision to expire June 30, 2012.

[INSERT TEXT HERE](#)

[INSERT TEXT HERE](#)

SWMP APPENDIX A – Floodplain Information

SWMP APPENDIX B – Soils Information

SWMP APPENDIX C – Probable Cost Forms

SWMP APPENDIX D – Calculations

SWMP APPENDIX E – Variance Request Details

COA SWMP DESIGN DRAWINGS CHECKLIST

THIS CHECKLIST REFERS TO REQUIREMENTS DESCRIBED WITHIN THE COA RULES AND REGULATIONS REGARDING STORMWATER DISCHARGES ASSOCIATED WITH CONSTRUCTION ACTIVITIES MANUAL AND SHOULD BE USED IN CONJUNCTION WITH THE MANUAL. THE SEQUENCE OF ITEMS HEREIN FOLLOWS THE SEQUENCE OF ITEMS IN THE MANUAL.

CHECKLIST PREPARER (PE)

Name: _____ Date: _____

I certify that the Stormwater Management Plan Narrative Report, Design Drawings, and this checklist were prepared by me or under my responsible charge.

Note: If the item is Not Applicable (N/A) please check "No."

Yes ___ No ___

Cover

- Insert Subdivision Name and Filing No.
- Project Name and Location

Yes ___ No ___

Owner/Operator(s) Contact Info

Yes ___ No ___

Engineer Contact(s) Contact Info

Yes ___ No ___

Approval Block

Yes ___ No ___

Required Statements

"THIS STORMWATER MANAGEMENT PLAN HAS BEEN PLACED IN THE CITY OF AURORA FILE FOR THIS PROJECT AND HAS BEEN DETERMINED TO COMPLY WITH THE APPLICABLE CITY OF AURORA STORMWATER MANAGEMENT CRITERIA. ADDITIONAL STORMWATER MANAGEMENT, EROSION AND SEDIMENT CONTROL MEASURES MAY BE REQUIRED OF THE OWNER OR HIS/HER AGENTS, DUE TO UNFORESEEN EROSION PROBLEMS OR IF THE SUBMITTED PLAN DOES NOT FUNCTION AS INTENDED."

"REVIEW OF THIS PLAN BY THE CITY OF AURORA SHALL NOT IMPLY THAT IT HAS BEEN REVIEWED FOR COMPLIANCE WITH THE REQUIREMENTS SET FORTH BY THE STATE OF COLORADO DEPARTMENT OF PUBLIC HEALTH AND ENVIRONMENT GENERAL PERMIT FOR STORMWATER DISCHARGES ASSOCIATED WITH CONSTRUCTION ACTIVITY."

"SEE APPROVED STORMWATER MANAGEMENT PLAN DESIGN DRAWINGS (SITE PLAN) FOR SITE SPECIFIC BEST MANAGEMENT PRACTICES."

Yes ___ No ___

Project Owner/Developer Signature Block

Yes ___ No ___

Plan Preparer Signature Block

Yes ___ No ___

Table of Contents

Yes ___ No ___

Required Statement

"Pursuant to Sections 138-440 and 138-442 of the Aurora Municipal Code, the Permittee shall locate, install, and maintain all Best Management Practices, including, but not limited to, erosion controls, sediment controls, drainage controls, and water quality BMPs as indicated in the approved Stormwater Management Plan (SWMP). The following notes are a requirement and shall be included in the SWMP narrative developed for this project and submitted for approval by the City. BMP installations shall be installed per the COA Standard Detail in effect at the time of installation or per the approved SWMP design drawing, a COA approved variance, or a COA approved design drawing plan amendment."

Yes ___ No ___

COA Stormwater Management Standard Notes

SITE DESCRIPTION

Yes ___ No ___

Site Location

- Site location including, Section, township, range, and latitude/longitude to the nearest 15 seconds.
- Project street location or nearest major cross streets
- If applicable, specific acknowledgement that the land is currently, or will ultimately be, owned or managed by the Parks, Recreation and Open Space Department.

Yes ___ No ___

Description of Adjacent Areas

- Provide a description of adjacent areas such as residential areas, roads, streams, lakes, runoff sources, etc, which might be affected by the proposed project's land disturbing activity.

Yes ___ No ___

Nature and Purpose of Construction Activity

Describe of the nature and purpose of the construction activity, note any vertical construction.

Yes ___ No ___

Construction Sequence

The proposed sequence for major activities should be described, including :

- An estimated project start

- An estimated project end date
- The sequence of major construction activities (Initial, interim, final or overlot grading, utilities, building, paving, over – excavation, etc.). This is expected to be a brief overview of the project as more detailed phasing information and specific BMPs will be addressed in later sections of the SWMP narrative report.

Yes ___ No ___

Area

The areas for the site should be described including any grading phases which will need all of the information by phase as well as for the overall project.

- Provide estimates of the total area of the site and the sub area within the site expected to undergo clearing, excavation or grading.
- Include an estimate of the excavation and fill volumes involved during the proposed construction.
- Include an estimate of how excavation and fill will be phased .
- Include an estimate of over-excavation areas and volumes (and type)and an estimate of offsite trucking volume (import and/or export).
- Description of phasing for sites disturbing more than 40 acres.:

Yes ___ No ___

Topography, Soils, and Rainfall Data

- Provide a summary describing the soil, the soil type, and hydrologic soil group, permeability, texture, soil erosion potential, depth, soil structure, etc. and potential impacts of the soil type on the quality of any stormwater discharge from the site.
- A description of the topography of the site, existing site conditions, drainage patterns, and existing site slopes should also be included.
- Imperviousness and Runoff Coefficients

Yes ___ No ___

Existing Vegetation

- Provide a description of the existing vegetation at the site and an estimate of the percent vegetative cover density prior to disturbance in an average square yard of the site. This requirement does not encompass hard surfaces or damaged areas. The consultant may have to evaluate vegetation from a nearby area if there has already been disturbance.
- A plan showing the existing major trees (4" diameter trunks and larger), tree masses, and shrub masses should be provided.
- Pre-disturbance vegetation density (average site density, not area, of vegetation)

Yes ___ No ___

Potential Sources of Pollution

- Identify and list the proposed location and description of any potential pollution sources anticipated to be used during the project, such as portable toilets, vehicle fueling, grout/cement mixers, storage of fertilizers, paints or chemicals and stockpiles, etc.
- Materials of concern (existing or proposed) may include, but are not limited to, raw materials, fuels, metallic products, hazardous substances designated under Section 101(14) of the Comprehensive Environmental Response, Compensation, and Liability Act (CERCLA), any chemical the facility is required to report pursuant to Section 313 of title III of the Superfund Amendments and Reauthorization Act (SARA), fertilizers, pesticides, ash, slag, sludge concrete washout, paints, solvents, and waste piles.

Yes ___ No ___

Non Stormwater Discharges

Identify and list the location and description of any anticipated non-stormwater components of the discharge.

Yes ___ No ___

Receiving Waters

- The site is within the Cherry Creek Drainage Basin
- The site is within the Aurora Reservoir Drainage Basin
- Description of receiving waters (typically 2-3 levels)
- Description of storm inlets and storm sewer systems
- Description of impaired waters or waters subject to TMDLs
- 100- Year Floodplain Status
- Description of wetlands

Yes ___ No ___

Site Features and Sensitive Areas to be Protected

- Describe unique site features including streams, stream buffers, wetlands, specimen trees, natural vegetation, steep slopes, or highly erodible soils that are to be preserved.
- Describe measures to protect these features.

Yes ___ No ___

Other Applicable Federal, State or Local Programs, Regulations or Restrictions

State any other regulations that are affecting the site (i.e. Regulation 72, Consent Decrees, etc).

- Endangered Species Certification
- Historic Preservation

Yes ___ No ___

STORMWATER MANAGEMENT CONTROLS

This section shall describe the stormwater management controls that will be used to control pollutants in stormwater discharge during construction activity.

Yes ___ No ___

SWMP Administrator and Important Contacts

- List Contact names and phone numbers for the SWMP Administrator, alternates, owner, developer, etc

Yes ___ No ___

Identification of Potential Pollutant Sources

All potential pollutant sources, including materials and activities, at a site must be evaluated for the potential to contribute pollutants to stormwater discharges.

BMPs for Stormwater Pollution Prevention

Yes ___ No ___

Structural Practices

– Clearly describe the initial/interim, post-paving, and permanent structural site management practices to control erosion and sediment transport. Practices may include, but are not limited to: silt fences, diversion dikes, sediment traps, sediment basins, temporary slope drains, inlet protection, outlet protection, check dams, curb/rock socks, vehicle tracking control pads, sediment control logs, compacted earthen berm, and terracing.

Yes ___ No ___

Non-Structural Practices

– Clearly describe initial/interim, post-paving, and permanent stabilization practices, including site specific scheduling of the implementation of these practices. Site plans should ensure that existing vegetation is preserved where possible and that all disturbed areas are stabilized. Non-structural practices may include, but are not limited to: temporary seeding, permanent seeding, mulching, sod stabilization, vegetative buffer strips, tree protection, landscaping, erosion control blankets/matting, soil retention matting, surface roughening, dust suppression, street sweeping (required weekly at a minimum), seasonal schedule, and preservation of mature vegetation.

Yes ___ No ___

Phase Construction Activity and BMP Implementation

This section shall describe the relationship between the phases of construction, and the implementation and maintenance of BMP controls and measures. For example, indicate which controls will be implemented during each of the following phases of construction: prior to clearing and grubbing for perimeter controls (installation of initial BMPs), clearing and grubbing, overlot grading, installation of interim BMPs, site construction, utility construction, vertical construction, other pertinent construction phases, final grading, stabilization, removal of BMPs, and Permit closeout.

Yes ___ No ___

a. Overlot Grading Specific Practices

– Address haul routes which may be designated on the SWMP updates and shall take into consideration drainage, erosion and sediment control BMPs, along with interim stabilization measures.
– Discuss interim stabilization may be provided via plan amendment by the contractor and the engineer at the Erosion Control Kick Off meeting. These measures shall be provided with timeframes and down gradient controls.
– Temporary drainage BMPs (diversion ditches, sediment traps or sediment basins) shall be maintained at all times including as the grading changes.
– Discuss timing and procedural requirements for implementation, maintenance and removal of these items during this period of construction.

Yes ___ No ___

b. Vertical Construction Requirements – See Appendix for Table of Required Information

– Staging areas change during construction regularly. Therefore, if “con/conex” boxes are to be utilized and if they are to include liquid pollutants, then a redundant BMP measure must be provided
– Site drainage will need to be maintained during vertical construction. Review conditions to ensure that it will continue to work as shown during the grading/utility timeframes.
– Provide redundant BMPs for generators to protect from fuel/hydraulic leaks
– Continuously review the down gradient BMPs within the impervious areas to ensure that conveyances, inlets and outlets are protected appropriately during this phase.
– Areas of disturbance outside of the building envelope shall still require BMPs. Continuously review the timing/phasing of the project to ensure the appropriate BMPs are implemented as construction continues.
– BMPs for keeping impervious surfaces clean may need to be enhanced or added to as construction continues.
– Review and implement BMP measures to control roof drainage. This becomes a point source and may cause extensive erosion on site.

Yes ___ No ___

Optional Section – To be included if the items in bullet points cannot be addressed with this report.

A Plan Amendment from the contractor shall be required to be submitted to the engineer of record and City of Aurora Water Engineering Plans Reviewer three (3) business days prior to the Erosion Control Kick Off Meeting. This submittal shall provide narrative information and the associated details required for vertical construction BMPs (structural and non-structural) that will be implemented during this phase of construction.

Yes ___ No ___

Material Handling and Spill Prevention

– Identify and describe how the sources of potential pollutants to stormwater discharges identified in Section 3.2 will be controlled through BMP selection and implementation. The information provided may address frequency, seasonal considerations, characteristics of the area and surface type, primary and secondary containment, proximity to drainageways and stormwater facilities.

Yes ___ No ___

SPILL RESPONSE -Cleanup and Removal Procedures

Yes ___ No ___

Dedicated Concrete or Asphalt Batch Plants

– Describe measures to control stormwater pollution from dedicated concrete batch plants or dedicated asphalt batch plants covered by the SWMP.

Yes ___ No ___

Vehicle Tracking Control

– Describe all practices implemented at the site to control potential sediment discharges from vehicle tracking. Practices must be implemented for all areas of potential vehicle tracking, and can include: minimizing site access; street sweeping or scraping; tracking pads; stabilized staging and parking areas; requiring that vehicles stay on paved areas on-site; wash racks; contractor education; and/or sediment control BMPs, etc

Yes ___ No ___ **Required BMP Description:** Mandatory sweeping of all internal and adjacent external paved areas is required on a weekly basis at a minimum. This applies until Initial Close-Out acceptance, and after that it will be on an as needed basis.

Yes ___ No ___ **Waste Management and Disposal, Including Concrete Washout**
- Clearly describe the practices implemented at the site to control stormwater pollution from all construction site wastes (liquid and solid), including concrete washout activities and liquid waste washouts, dumpsters, worker trash, and portable toilets.

Yes ___ No ___ **BMP Specifications**
BMP Details for installation and maintenance shall be the City of Aurora Standard Details in Appendix D of the (City of Aurora Rules and Regulations Regarding Stormwater Quality Discharge for Construction Activities (SWMP Manual)), latest revision

Yes ___ No ___ **Groundwater and Stormwater Dewatering**
- The SWMP shall clearly describe the practices to be implemented at the site to control stormwater pollution from the dewatering of groundwater or stormwater from excavations, wells, etc.

Yes ___ No ___ **Developer/Builder Specific Practices**
Include a description of standard practices of the company for whom this SWMP is being developed. At a minimum it shall include:
- Standard practices for construction operations during wet weather conditions and winter weather conditions
- Methods used to obtain compliance from sub-contractors (i.e. fines, education, etc)
- Stormwater education of personnel practices
- Company Standard Operating Procedures (as appropriate)
- Describe any standard construction practices that will be used on the site such as material loading and unloading practices, lot controls, lot access etc.

FINAL STABILIZATION AND LONG TERM STORMWATER MANAGEMENT

Yes ___ No ___ **Final Stabilization Measures**
Include a description of the proposed measures to be used to achieve final stabilization and long-term stormwater control. Revegetation with seeding and mulching, revegetation with seeding with erosion control blankets, landscaping, green roofs, permeable paving, permanent water quality ponds and permanent outlet protection are examples of final stabilization measures.

Yes ___ No ___ **Seed Mix Information**
Provide the name of the City of Aurora standard seed mix(es) that may be appropriate for the site and the soils anticipated for the site and the preferred method(s) for protecting the seed.

Yes ___ No ___ **Final Stabilization Notes**
1) Final stabilization is reached when all soil disturbing activities at the site have been completed, and uniform vegetative cover has been established with a density of at least 70% of pre-disturbance levels, or equivalent permanent physical erosion reduction methods have been employed.
2) Vegetative coverage density does not apply to paved areas, walks, buildings, or other hard surface impermeable areas.
3) Establishment of a vegetative cover capable of providing the erosion control equivalent to pre-existing conditions at the site can be considered final stabilization (i.e. landscape rocks, mulch, shrubs, etc). This determination will be made by the City of Aurora Water Department Erosion Control Program Staff prior to the close-out of the permit.

Yes ___ No ___ **INSPECTIONS AND MAINTENANCE**
This section shall describe procedures to inspect and maintain, in good effective operating condition, the vegetation, erosion, and sediment control measures and all other protective measures identified in the plan.

Yes ___ No ___ **Required Language** The following are the required frequencies of inspections:
i. Prior to Initial Closeout Acceptance: Permittee shall self-inspect the site at least every 7 calendar days and within 24-hours after the end of any precipitation event or snowmelt event that results in runoff and causes surface erosion, except as allowed in Item iii below.
ii. Following Initial Closeout Acceptance and until permit closeout: Permittee shall self-inspect the site at least every 30 calendar days, and within 24-hours after the end of any precipitation event or snowmelt event that results in runoff and causes surface erosion
iii. Post-Precipitation Event Inspections for Temporarily Idle Sites: If a site is temporarily idle and no construction activities will occur during the 48 hours following a storm event, the post-precipitation event (including snowmelt) inspection shall be conducted prior to commencing construction activities on the site, but no later than 72 hours following the storm event.
- Describe all other procedures necessary to inspect and maintain BMPs on this site.

Yes ___ No ___ **PROBABLE COST FOR INSTALLATION OF BMPs**
- Initial BMP Total Cost
- Initial BMP Maintenance Cost
- Post-Paving BMP Total Cost
- Post-Paving BMP Maintenance Cost
- Fiscal Security amount

Yes ___ No ___ **CALCULATIONS MADE FOR THE DESIGN**
Include calculations made in the design of the SWMP, including calculations for sizing of sediment basins, design of erosion control matting, soil retention matting, sediment traps, diversion ditches, temporary stream crossings, weir sizing, or sizing of outlet protection riprap in the appendix with a summary of the results below.

Yes___ No___ **VARIANCE REQUESTS**

Yes___ No___ **ADDITIONAL SECTIONS** [Add additional sections here to meet requirements of other regulations]

Yes___ No___ **REFERENCES**

Yes___ No___ **APPENDIX A – Floodplain Information**

Yes___ No___ **APPENDIX B – Soils Information**

Yes___ No___ **APPENDIX C – Probable Cost Forms**

Yes___ No___ **APPENDIX D – Calculations (ie sed pond sizing)**

Yes___ No___ **APPENDIX E – Variance Request Details**

Yes___ No___ **APPENDIX F – Vertical Construction Matrix**

General SWMP Design and Drawing Requirements

Yes___ No___ 24" x 36" plan sheets, and complies with the basic Civil Construction Plan Requirements in Section 2 of the COA Roadway Design and Construction Specifications and the Plan and Drafting Standards in Section 3.

SWMP Drawing Cover Sheet.

Yes___ No___ Since the SWMP drawings are normally part of a comprehensive set of construction drawings for development, one cover sheet may suffice for the entire set of drawings. It shall include the following information related to the SWMP portion of the plan set. Additional requirements shall be required for the other portions of the construction drawings, contact the Public Works for a complete list of cover sheet requirements.

Yes___ No___ Project name.

Yes___ No___ Project address (if applicable).

Yes___ No___ Owner address, phone number, fax number and contact name.

Yes___ No___ Design firm's name and address, phone number, fax number and contact name.

Yes___ No___ Plan sheet index.

Yes___ No___ Design Engineer's Signature Block.

The following note:

Yes___ No___ THIS STORMWATER MANAGEMENT PLAN HAS BEEN PLACED IN THE CITY OF AURORA FILE FOR THIS PROJECT AND HAS BEEN DETERMINED TO COMPLY WITH THE APPLICABLE CITY OF AURORA STORMWATER MANAGEMENT CRITERIA. ADDITIONAL STORMWATER MANAGEMENT, EROSION AND SEDIMENT CONTROL MEASURES MAY BE REQUIRED OF THE OWNER OR HIS/HER AGENTS, DUE TO UNFORESEEN EROSION PROBLEMS OR IF THE SUBMITTED PLAN DOES NOT FUNCTION AS INTENDED. THE REQUIREMENTS OF THIS SWMP SHALL RUN WITH THE LAND AND BE THE OBLIGATION OF THE PERMITEE(S) UNTIL SUCH TIME AS THE SWMP IS PROPERLY COMPLETED, MODIFIED OR VOIDED.

SWMP Drawing Design Engineer's signature block with name, date, and Professional Engineer registration number. Signature block shall include the following note:

Yes___ No___ The *STORMWATER MANAGEMENT PLAN* included herein has been prepared under my direct supervision in accordance with the requirements of the *CITY OF AURORA RULES AND REGULATIONS REGARDING STORMWATER DISCHARGES ASSOCIATED WITH CONSTRUCTION ACTIVITIES Manual*, AS AMENDED.

Yes___ No___ City Acceptance Block.

Yes___ No___ General Location Map at a Scale of 1-inch to 1000-feet to 2000-feet indicating:

Yes___ No___ General vicinity of the site location.

Yes___ No___ Major roadway names.

Yes___ No___ North arrow and scale.

Yes___ No___ Standard Statement and Required Standard Notes

SWMP Drawing Index Sheet.

Yes___ No___ For projects that require multiple plan-view sheets to adequately show the project area (based on the specified scale ranges), a single plan-view sheet shall be provided at a scale appropriate to show the entire site on one sheet. Areas of coverage of the multiple blow-up sheets are to be indicated as rectangles on the index sheet.

Yes___ No___ Property lines

Yes___ No___ Sedimentation ponds with unique pond names or identifiers

Yes___ No___ Sedimentation pond basins delineated and areas of disturbed and non-disturbed labeled

- Yes___ No___ Phasing with areas including cut and fill volumes and the phasing sequence
- Yes___ No___ Hydrologic features shown and labeled
- Yes___ No___ Benchmark
- Yes___ No___ Major soil stockpiles and borrow areas
- Yes___ No___ Site access points
- Yes___ No___ Limits of construction
- Yes___ No___ Initial BMPs required for permit execution may be shown on the Index Sheet

Initial SWMP Drawing.

- Yes___ No___ This plan sheet shall provide grading, erosion and sediment controls for the initial clearing, grubbing and grading of a project, as well as road grading and utility construction. At a minimum, it shall contain:
- Yes___ No___ Property Lines.
- Yes___ No___ Drawings shall be at a minimum of 1:50 scale for single-family residential development, and a minimum of 1:30 scale for multi-family or commercial development.
- Yes___ No___ Existing and proposed easements.
- Yes___ No___ Existing topography at one or two-foot contour intervals, extending a minimum of 100 feet beyond the property line.
- Yes___ No___ Proposed contours screened back.
- Yes___ No___ Grading phasing including grade tie ins between phases and any additional BMPs needed between phases.
- Yes___ No___ Over-excavation areas and volumes.
- Yes___ No___ Provide slope labels for graded slopes and channels/drainages.
- Yes___ No___ Identify areas of cut and fill.
- Yes___ No___ Existing trees and tree protection measures
- Yes___ No___ Location of any existing structures or hydrologic features within the mapping limits including 100-year floodplain limits.
- Yes___ No___ Directional flow arrows.
- Yes___ No___ Benchmark used for project.
- Yes___ No___ Limits of construction encompassing all areas of work, access points, and utility tie-in locations in on-site and off-site locations.
- Yes___ No___ Show stream corridors and other resource areas to be preserved and all other areas outside the limits of construction shall be lightly shaded to clearly show area not to be disturbed.
- Yes___ No___ Location of stockpiles, including topsoil, borrow areas, imported aggregates, and excess material.
- Yes___ No___ Location of storage and staging areas for equipment, fuel, lubricant, chemicals (and other materials) and waste storage.
- Yes___ No___ Location of borrow or disposal areas.
- Yes___ No___ Location of temporary roads.
- Yes___ No___ Show and label tributary drainage areas for all Temporary Sediment Basins.
- Yes___ No___ Locations for any dedicated asphalt or concrete batch plants.
- Yes___ No___ Location, map symbol, and letter callouts of all initial erosion and sediment control BMPs.
- Yes___ No___ Information to be specified for each BMP, such as type and dimensions, as called for in the Standard Notes and Details.
- Yes___ No___ Indicate BMP's that may have different timing installations or removals with clear notes.
- Yes___ No___ BMPs specific to the vertical construction , as applicable
- Yes___ No___ Required COA SWMP design drawing notes, approval blocks, and additional information

- Yes___ No___ Interim measures and waste handling
- Yes___ No___ Clearly identify initial BMPs required for permit execution
- The following note:
- Yes___ No___ SEE COVER SHEET OF CITY OF AURORA STANDARD NOTES AND DETAILS FOR LEGEND OF BMP NAMES AND SYMBOLS.
- Yes___ No___ CITY OF AURORA approval block.
- Yes___ No___ Other information as may be reasonably required by City of Aurora.

Final SWMP Drawing.

This plan sheet shows controls for final completion of the site including roadway, curb and gutter, walks, and buildings. At a minimum, this plan sheet shall contain the indicated information:

- Yes___ No___ Final topography (existing topography need not be shown in areas having proposed contours)
- Yes___ No___ Existing trees and tree protection measures with reference to Aurora Parks, Recreation and Open Space standard details
- Yes___ No___ Existing Initial and Interim BMPs that will remain shall be shown. Dimension information need not be repeated.
- Yes___ No___ Benchmark used for project.
- Yes___ No___ Drawings shall be at a minimum of 1:50 scale for single-family residential development, and a minimum of 1:30 scale for multi-family or commercial development.
- Yes___ No___ Directional flow arrows on all drainage features.
- Yes___ No___ Denote any Initial BMPs that are to be removed and any resulting disturbed area to be stabilized.
- Yes___ No___ Provide slope labels for graded slopes, channels/drainages, and streets within and adjacent to the project.
- Yes___ No___ Clearly show storm sewer system, both proposed and existing.
- Yes___ No___ Show locations for storage areas, trailers, materials, concrete washouts, etc.
- Yes___ No___ BMPs specific to the vertical construction , as applicable
- Yes___ No___ Show or provide adequate notes for individual lot BMPs.
- Yes___ No___ Location of all Final erosion and sediment control BMPs, permanent landscaping, and measures necessary to minimize the movement of sediment off site until permanent vegetation can be established.
- Yes___ No___ Show area of buildings, pavement, sod, and permanent landscaping (define types) per approved Landscape Plan, or other improvement plan.
- Yes___ No___ Show seeding, mulching, and landscaping everywhere except buildings, pavement areas and permanent landscaping areas.
- Yes___ No___ Show other BMPs considered by the Designer Engineer to be appropriate for the construction of the site.
- Yes___ No___ Show the BMPs to be removed at the end of construction.
- Include the following notes:
- Yes___ No___ SEE COVER SHEET OF CITY OF AURORA STANDARD NOTES AND DETAILS FOR LEGEND OF BMP NAMES AND SYMBOLS.
- Yes___ No___ SEE CONSTRUCTION PLANS FOR DETAILS OF PERMANENT DRAINAGE FACILITIES SUCH AS DETENTION FACILITIES, CULVERTS, STORM DRAINS, AND OUTLET PROTECTION.
- Yes___ No___ COA acceptance block.
- Yes___ No___ Other information as may be reasonably required by City of Aurora.

THIS PAGE IS INTENTIONALLY BLANK

Appendix F – Probable BMP Cost Sheets

The Standardized Probable BMP Cost Sheets are required to be attached to the Stormwater Management Plan (SWMP) report and submitted at the time of the permit application. The probable cost sheets are used in determining the amount of the fiscal security.

THIS PAGE IS INTENTIONALLY BLANK

PROBABLE BMP COST SHEETS

Standardized Probable Cost Spreadsheet for Initial BMPs

Project Name: _____ Date: _____

No.	BMP	ID	Unit	Installation Unit Cost	Initial / Interim Quantity	Initial / Interim Cost
1	Check Dam	CD	LF	\$ 24.00		\$ -
2	Compost Blanket	CB	SF	\$ 0.50		\$ -
3	Compost Filter Berm	CFB	LF	\$ 4.00		\$ -
4	Concrete Washout Area	CWA	EA	\$ 1,000.00		\$ -
5	Construction Fence	CF	LF	\$ 5.00		\$ -
6	Curb Socks	CS	EA	\$ 20.00		\$ -
7	Diversion Channel	DC	EA	\$ 2,000.00		\$ -
8	Diversion Dike	DD	LF	\$ 1.50		\$ -
9	Dewatering	DW	EA	\$ 600.00		\$ -
10	Erosion Control Blanket	ECB	SY	\$ 5.00		\$ -
11	Inlet Protection - All types	IP	EA	\$ 300.00		\$ -
12	Outlet Protection	OP	EA	\$ 250.00		\$ -
13	Reinforced Check Dam	RCD	LF	\$ 36.00		\$ -
14	Rock Socks	RS	LF	\$ 10.00		\$ -
15	Rough Cut Street Control	RCS	EA	\$ 50.00		\$ -
16	Sediment Basin	SB	CY	\$ 3.00		\$ -
17	Sediment Control Log	SCL	LF	\$ 3.00		\$ -
18	Sediment Trap	ST	EA	\$ 600.00		\$ -
19	Seeding & Mulching (Less than 10 Acres)	SM	AC	\$ 2,500.00		\$ -
	(Greater than 10 Acres)	SM	AC	\$ 1,500.00		\$ -
20	Silt Fence	SF	LF	\$ 2.00		\$ -
21	Silt Fence - Reinforced	SF-R	LF	\$ 4.00		\$ -
22	Stabilized Staging Area	SSA	SY	\$ 2.00		\$ -
23	Surface Roughening	SR	AC	\$ 600.00		\$ -
24	Temporary Slope Drain	TSD	LF	\$ 25.00		\$ -
25	Temporary Stream Crossing	TSC	EA	\$ 1,500.00		\$ -
26	Terracing	TER		\$ -		\$ -
27	Tree Protection Fencing	TP	LF	\$ 5.00		\$ -
28	Vehicle Tracking Control	VTC	EA	\$ 1,000.00		\$ -
29	VTC with Wheel Wash	WW	EA	\$ 1,500.00		\$ -
30	Mobilization (required on all projects)	MB	LS	\$ 5,000.00		\$ -
31	Pond Maintenance/Sediment Removal (Based on area tributary to the pond)	PM	AC	\$ 1,000.00		\$ -
32	Street Maintenance (Based on lane miles of streets within project and adjacent to project)	STM	LM	\$ 1,500.00		\$ -
33	Other: _____			\$ -		\$ -
Subtotal Cost of Initial BMPs						\$ -
34	Maintenance (required on all projects)		%	25% of Subtotal		\$ -
Total Cost of Initial & Interim BMPs						\$ -
Fiscal Security Amount						\$ -

* For Temporary Batch Plant BMPs allow \$5000.00 in line 32.

** Fiscal Security required is the higher amount of either the Initial or the Post-Paving, not both.

THIS PAGE IS INTENTIONALLY BLANK

PROBABLE BMP COST SHEETS

Standardized Probable Cost Spreadsheet for Post Paving BMPs

Project Name: _____ Date: _____

No.	BMP	ID	Unit	Installation Unit Cost	Initial / Interim Quantity	Initial / Interim Cost
1	Check Dam	CD	LF	\$ 24.00		\$ -
2	Compost Blanket	CB	SF	\$ 0.50		\$ -
3	Compost Filter Berm	CFB	LF	\$ 4.00		\$ -
4	Concrete Washout Area	CWA	EA	\$ 1,000.00		\$ -
5	Construction Fence	CF	LF	\$ 5.00		\$ -
6	Curb Socks	CS	EA	\$ 20.00		\$ -
7	Diversion Channel	DC	EA	\$2,000		\$ -
8	Diversion Dike	DD	LF	\$ 1.50		\$ -
9	Dewatering	DW	EA	\$ 600.00		\$ -
10	Erosion Control Blanket	ECB	SY	\$ 5.00		\$ -
11	Inlet Protection - All types	IP	EA	\$ 300.00		\$ -
12	Perimeter Erosion Control BMPs (Lot)	PC	EA	\$ 500.00		\$ -
13	Outlet Protection	OP	EA	\$ 250.00		\$ -
14	Reinforced Check Dam	RCD	LF	\$ 36.00		\$ -
15	Rock Socks	RS	LF	\$ 10.00		\$ -
16	Sediment Basin	SB	CY	\$ 3.00		\$ -
17	Sediment Control Log	SCL	LF	\$ 3.00		\$ -
18	Sediment Trap	ST	EA	\$ 600.00		\$ -
19	Seeding & Mulching (Less than 10 Acres)	SM	AC	\$ 2,500.00		\$ -
	(Greater than 10 Acres)	SM	AC	\$ 1,500.00		\$ -
20	Silt Fence	SF	LF	\$ 2.00		\$ -
21	Silt Fence Reinforced	SF-R	LF	\$ 4.00		\$ -
22	Stabilized Staging Area	SSA	SY	\$ 2.00		\$ -
23	Surface Roughening	SR	AC	\$ 600.00		\$ -
24	Temporary Slope Drain	TSD	LF	\$ 25.00		\$ -
25	Temporary Stream Crossing	TSC	EA	\$ 1,500.00		\$ -
26	Terracing	TER		\$ -		\$ -
27	Tree Protection Fencing	TP	LF	\$ 5.00		\$ -
28	Vehicle Tracking Control	VTC	EA	\$ 1,000.00		\$ -
29	VTC with Wheel Wash	WW	EA	\$ 1,500.00		\$ -
30	Mobilization (required on all projects)	MB	LS	\$ 5,000.00		\$ -
31	Pond Maintenance/Sediment Removal (Based on area tributary to the pond)	PM	AC	\$ 1,000.00		\$ -
32	Street Maintenance (Based on lane miles of streets within project and adjacent to project)	STM	LM	\$ 1,500.00		\$ -
33	Other: _____			\$ -		\$ -
Subtotal Cost of Post Paving BMPs						\$ -
34	Maintenance (required on all projects)		%	25% of Subtotal		\$ -
Total Cost of Post Paving BMPs						\$ -
Fiscal Security Amount						\$ -

Note: Do not include costs for BMPs carried over from the Initial Plan, only new installations

* For Temporary Batch Plant BMPs allow \$5000.00 in line 32.

** Fiscal Security required is the higher amount of either the Initial or the Post-Paving, not both.

THIS PAGE IS INTENTIONALLY BLANK

Appendix G – Guidance for Interpreting an Inspection Report

An inspection report is typically filled out by a City of Aurora Environmental Inspector when inspecting a construction site.

- A sample blank Inspection Report is provided here for the Permittee's information.
- A sample Inspection Report with explanations of each field is provided here to help the Permittee understand what an inspector will be looking for. Typically, an inspection report will be supplemented with pictures taken during the site visit, to illustrate BMPs working well, BMPs requiring maintenance, and BMPs that may be failing.

THIS PAGE IS INTENTIONALLY BLANK



**CITY OF AURORA
STORMWATER MANAGEMENT &
ENVIRONMENTAL CONTROL INSPECTION REPORT**



Project Name		Date	
Inspector		Phone	
		Email	
Site Representative(s)			
Inspection Type	<input type="checkbox"/> Initial <input type="checkbox"/> Follow-up <input type="checkbox"/> Post Precip <input type="checkbox"/> Routine <input type="checkbox"/> Closeout	SWQ Permit #	

Best Management Practices	Practice Utilized	Status (1)	Action(s) Required
Procedural/Administrative	X		Permittee is/ is not conducting 7 day and post precipitation self inspections. SWMP(narrative & drawings) accurately/does not accurately depict(s) site conditions. Permittee is maintaining the site's maintenance logs on a consistent/inconsistent basis. Phased inspections for this site are/are not required.
Check Dams			
Curb Socks			
Diversion Ditch/Berm			
Swale			
Inlet Protection			
Outlet Protection			
Sediment Basin/Trap/WQP*			
Silt Fence			
Slope & Surface Stabilization *			
Perimeter/Interior Controls			
Vehicle Tracking Controls			
Concrete Washout Area			
Materials/Waste Handling Practices			
COA Plan Modification Field Approval			Grading ___Y ___N COA Detail ___Y ___N APPROVED ___Y ___N Drainage ___Y ___N Previously Approved Detail ___Y ___N

⁽¹⁾ Status: (W) = Working; (V) = Violation in need of Maintenance; <V> = Significant Violation(s), immediate action required; (N) = installation Needed

A <V> on this document signifies a non-compliant SMEC report. This is not a Notice of Violation.

The party responsible for the above referenced permit must address all violations **immediately** upon completion of the inspection, regardless of Permittee attendance. Permittee shall provide written and photo documentation of significant violations <V> to COA personnel indicating remediation within 2 business days. If a significant violation <V> cannot be completed immediately, a remediation action plan must be submitted to COA Erosion Control Supervisor within 2 business days, and the corrective action must be completed within the accepted time frames. A copy of this report has provided to a site/project representative.

Delivery Method: Email/Fax/Hand Delivered to: _____ Date _____

Pursuant to Sections 138-440 and 138-442 of the Aurora Municipal Code, BMPs shall be located, installed, and maintained as indicated in the Erosion and Sediment Control Plan. (also known as the Stormwater Management Plan).

See the COA Rules and Regulations: Regarding Stormwater Discharges associated with Construction Activities
<http://www.auroragov.org/stellent/groups/public/documents/article-publication/401680.pdf>

Representative Photo Log of Site Visit,



Guidance for Following the City of Aurora’s Environmental Inspection Process, the Documented Stormwater Management and Environmental Controls Inspection Report, Addressing any Findings of Non-Compliance and Responding to a Notice of Violation

The City of Aurora’s (COA) Environmental Inspection process and procedures are predicated on The Colorado Department of Public Health and Environment (CDPHE) – Water Quality Control Division (WQCD) field inspection process for stormwater discharges during construction activities.

PART I – The Inspection

COA Inspectors conduct random, unannounced field inspections to verify permit compliance. These inspections are meant to evaluate site conditions to determine if there are any existing or potential impacts to water quality and the MS4. A typical inspection will entail review of the **permittee’s paperwork**, visual examinations of site conditions, and a review of work practices and structural and non-structural Best Management Practices (BMPs) throughout a construction project. These BMPs may be structural, physically installed features or administrative/procedural activities that are a part of the work practices and procedures. Installed BMPs will be reviewed for correct application, correct installation, adequacy, integrity and maintenance. City approved drawings for the project and COA Rules and Regulations, including details, are used to verify features that should be in place, at specific locations.

The typical inspection will entail visual examinations of:

- Site Boundaries and perimeters for containment with some form of sediment barrier
- Site outfalls/discharge points for evidence of sediment migration, pollutants, sediment deposition or erosion
- Ponds, Traps, Basins, Drainage Ditches/Swales and overall site drainage for appropriate management
- Disturbed areas for temporary stabilization or means of cover
- Areas that have final landscaping for germination, adequate cover and/or need for re-application or maintenance
- Paved surfaces for evidence of dirt tracking, dirt ramps, need for cleaning, and the installation of Vehicle Tracking Control Pads and sediment barriers installed at areas adjoining disturbed areas
- Inlets for correct and adequate protection, maintenance or staining from pollution sources
- Material Storage and Waste Handling areas and practices to verify that appropriate measures are in place and exercised to manage all potential pollution sources. This will include; waste receptacles, staging areas, liquid waste washout areas, fuel storage, portable toilets and waste piles.
- **Verification of Permittee’s inspections, maintenance logs and living document updates**

This listing is not intended to be all-inclusive. Additional information on BMPs can be found in the Rules & Regulations.

Part II – Disposition or Status of the Inspection

Once the inspection has been completed with photo documentation, a COA Stormwater Management and Environmental Controls (SMEC) Inspection Report (see Part III of this Guidance Document) will be generated with a representative photo log that illustrates any concerns or items of non-compliance noted on the site. Occasionally the Inspector may have recommendations or suggestions to assist the site. These suggestions should not be interpreted as mandates for specific installations

All items of non-compliance noted on the SMEC report must be addressed and completed promptly regardless of whether they are significant violations or violations requiring maintenance.

If the recipient of the report does not address the findings on the COA SMEC report, they are in violation of their COA and State Stormwater Permit (Part I, A.3.e. & Part I, C.1.h.) and the Enforcement Escalation Policy shall begin to be implemented. The SMEC Report is not intended to fulfill the self-inspecting requirements of the Permittee; nor does the SMEC Report or accompanying photo log aim to document every instance of non-compliance on a site. It is not typically the intent of the Inspection to provide a thorough site analysis. The photo log is supplied to provide representative examples or demonstrate areas that require action or document a violation. It is the responsibility of the operator/contractor/developer/builder/owner to inspect their site and address all instances of non-compliance or areas requiring maintenance and those of significance, not just those examples cited on the SMEC Report or photo documentation. Reports are typically emailed within two (2) business days of the inspection.

Passing Inspection: BMP features are noted to be working in all instances and the permittee's paperwork is up to date and meets the City of Aurora permit requirements. Findings that fall within these categories will yield a "Passing" inspection.

Non-compliant Inspection: If any violations are documented on a report, this constitutes a "Non-compliant" inspection for the site. Site conditions that would constitute violations include but are not limited to; critical BMPs that are not installed, BMPs that are not installed correctly, portable toilets that are improperly stationed on paved surfaces or at curb flowlines, evidence of liquid wastes that are discharged directly onto the ground or paved sections without full containment, failure to implement BMPs to effectively control tracking onto roadways, a concrete washout area that is near failure, a pond that has no means of discharge and fuel leaks/spills that have not been properly remediated. Significant violation status may also be assigned to instances or areas of repeated neglect and/or deficiencies from previous reports that have not been adequately addressed.

Enforcement Escalation Policy Enforcement Escalation can occur in several different ways and there are several types of Enforcement Escalation within the City of Aurora. Please refer to the Enforcement Escalation Policy (narrative and table) for further information. **The "Non-compliant" inspection report**, with findings that are documented as *violations*, should not be mistaken for the written NOV (e.g. the stand-alone SMEC report is not a NOV). For example, a Notice of Violation (NOV) is a written notification to an operator/contractor/developer/owner/builder that their site is in significant violation and needs immediate resolution. The NOV will typically be accompanied by a SMEC Inspection Report that documents the findings. Site conditions that would prompt an immediate NOV could be but are not limited to; work beginning without an executed permit, washout feature losing containment, evidence of an illicit discharge, off-site release of sediment or other pollutants, inappropriate stream crossings, no State or COA Permit, flagrant washout violations, or a threatening, imminent

failure of a BMP that has the potential for an environmental impact. A NOV may also be issued for repeated non-compliant inspections.

Part III – The SMEC Report Form



**CITY OF AURORA
STORMWATER MANAGEMENT &
ENVIRONMENTAL CONTROL INSPECTION REPORT**



Project Name	<u>Name of Project</u>	Date	
Inspector	<u>Who conducted the inspection</u>	Phone	
		Email	
Site Representative(s)	<u>Permittee's Site Representative</u>		
Inspection Type	<input type="checkbox"/> Initial <input type="checkbox"/> Follow-up <input type="checkbox"/> Post Precip <input type="checkbox"/> Routine <input type="checkbox"/> Closeout	SWQ Permit #	<u>COA Permit Number</u>

Best Management Practices	Practice Utilized	Status (1)	Action(s) Required
Procedural/Administrative	1.	2.	3.
Check Dams	↓	↓	↓
Curb Socks			
Diversion Ditch/Berm			
Swale			
Inlet Protection			
Outlet Protection			
Sediment Basin/Trap/WQP*			
Silt Fence			
Slope & Surface Stabilization *			
Perimeter/Interior Controls			
Vehicle Tracking Controls			
Concrete Washout Area			
Materials/Waste Handling Practices 4.	↓	↓	↓
COA Plan Modification Field Approval			Grading ___Y ___N COA Detail ___Y ___N APPROVED ___Y ___N Drainage ___Y ___N Previously Approved Detail ___Y ___N

(1) **5.** Status: (W) = Working; (V) = Violation in need of Maintenance; <V> = Signification Violation(s), immediate action required; (N) = installation Needed

A <V> on this document signifies a non-compliant SMEC report. This is not a Notice of Violation. The party responsible for the above referenced permit must address all violations **immediately** upon completion of the inspection, regardless of Permittee attendance. Permittee shall provide written and photo documentation of significant violations <V> to COA personnel indicating remediation within 2 business days. If a significant violation <V> cannot be completed immediately, a remediation action plan must be submitted to COA Erosion Control Supervisor within 2 business days, and the corrective action must be completed within the accepted time frames. A copy of this report has provided to a site/project representative.

Delivery Method: Email/Fax/Hand Delivered to: _____ **Date** _____

Pursuant to Sections 138-440 and 138-442 of the Aurora Municipal Code, BMPs shall be located, installed, and maintained as indicated in the Erosion and Sediment Control Plan. (also known as the Stormwater Management Plan).

See the COA Rules and Regulations: Regarding Stormwater Quality Discharge for Construction Activities
<http://www.auroragov.org/stellent/groups/public/documents/article-publication/401680.pdf>

1. Boxes in this column will be checked if the features are noted on the site.
2. Entries in this column will indicate the status of the features: (W) = Working; (V) = Violation in need of Maintenance; **<V>** = Significant Violation(s), immediate action required; (N) = Installation Needed.
3. Entries in this column will identify findings, what issues were noted and/or what corrective actions need to be completed to resolve the issue/violation.
4. Additional boxes may be used to add BMP features not covered on the standard form.
5. Definitions of findings noted above.

Part IV – How to Respond to a Non-Compliant SMEC Report

When an Inspector completes a SMEC Report, the inspector will email or physically deliver a copy of the report to the designated site representative. The Permittee has two (2) business days from the end of the inspection, not when the Permittee receives the report, to provide written and photo documentation to be submitted to the Erosion Control Inspection Supervisor for review. The City reserves the right to conduct a follow up inspection on the site within the third (3rd) to fifth (5th) business day to verify that the issue has been addressed if the documentation is not clear or the impacts to the MS4 were serious.

Violations and Remedy Strategies

The suggestions and information below provide examples, ideas, and a starting point around which conducting a root cause analysis can lead to remedy of any violations. This discussion is not all encompassing and does not provide exhaustive detail. This document seeks to provide basic guidance.

When the site receives a non-compliant SMEC report, the operator must decide how best to rectify the non-compliant site conditions. The first course of action is to review the Report with key site personnel and make an assessment regarding where, how and why the violations are occurring. Depending on what the analysis reveals, various options may be available to resolve the findings of violations:

- **Waste Handling Practices** - Investigate what types of wastes are causing the violations and develop strategies, policies and possibly training awareness classes for the trades and subcontractors to control liquid and other wastes on the site. Consider providing individual liquid waste washout facilities for **the site's** trade partners. Consider asking COA to provide compliance assistance training for the SWMP Administrator and **the site's** trade partners.
- **Structural BMPs** - If structural BMPs (check dams, curb socks, silt fence, inlet protection, etc.) are a cause of **the site's** violations, then you should determine why the structural BMPs are not compliant. Are they poorly maintained, incorrectly installed or missing altogether? Is there a designated person to conduct your weekly site inspections? Does a system exist that will allow the SWMP Administrator or designated representative to respond to **the permittee's** own internal inspection findings in a timely manner so BMPs are in continuous operating order? Are all the designated BMPs on the approved COA SWMP(narrative and design drawings) set actually installed in the field? Does the SWMP reflect current site conditions?
- **Procedural BMPs** - If procedural BMPs (examples: 40-acre phase rule, tracking onto paved sections) are the cause of non-compliant findings, as SWMP administrator, one should consider developing internal policies, procedures, phasing and scheduling agreements with

your grading (or other) contractor which will enable work to continue within the constraints of the 40-acre limit, and/or controlling tracking onto paved sections.

- **Spill Prevention** – Does **the site's** SWMP adequately identify and describe all potential pollution sources that may be found on your site? Does fuel stored on site have secondary containment? How will the site personnel respond to fuel spills/leaks? Is there a spill response kit on site with a containment drum for contaminated soils? Are there trained personnel on site who can respond to equipment spills/leaks?
- **Dewatering** – Does the site have a CDPHE Construction Dewatering Permit? What sort of dewatering method will you be using to stay compliant with the Permit? Is there an approved dewatering plan? Does the SWMP Administrator understand the difference between groundwater and surface water and how the permit conditions may vary depending on which the site may encounter? If the site is going to flush or dewater a pipeline, has a CDPHE Hydrostatic Discharge Permit been obtained? Is the site following the dewatering plan that has been reviewed and accepted by the City of Aurora?
- **Slope and Surface Stabilization** – Erosion control. This means that the site operator must seek to stabilize all areas that have been disturbed within 2 weeks of reaching final grade, and when areas are dormant. It is not enough to install a silt fence (a sediment control BMP) at the toe of a long slope or site perimeter and consider this area to be compliant. All disturbed areas require some means or temporary or permanent stabilization measures for erosion control. Is there a plan for temporary measures due to weather in place?

Part V – How to respond to a COA Enforcement Action

The City shall issue Enforcement Action based upon the conditions outlined in the Enforcement Escalation Policy (narrative and table). For example, a site may receive an NOV for having failed **to respond to the City's** non-compliant SMEC reports, egregious site conditions, off-site releases. As the Permittee and/or SWMP Administrator, you are responsible for the activities of all trade partners, vendors and contractors conducting work on the site. As the Permittee and/or SWMP Administrator, you must ensure that they are compliant with Federal, State and City Stormwater requirements. Below are listed seven conditions that can result in an Enforcement Action being issued.

1. **Repeated or on-going violations.** If your site has received three failing COA SMEC reports, a NOV will be issued. A NOV is issued in this instance because the inspection results establish a trend of neglect and permit noncompliance.
2. **Illicit discharge/off-site release.** Release of sediment or other pollutant(s) off-site, into a stormdrain or into a State Water. This may also have an Immediate Clean Up Order attached to the NOV.
3. **Waterway impacts or dewatering violations.** Stream crossings without an appropriate Temporary Stream Crossing feature installed or diversions that have been installed without review and approval from COA, equipment in the waterway with no BMPs. Dewatering violations may include discharge to the MS4 without an approved plan or not having the dewatering permit in place.
4. **No Permit.** Failure to have a State or COA Stormwater Permit issued or executed
5. **Waste Handling Practices.** Evidence of numerous uncontained liquid waste washouts, lack of measures to contain or adequately manage liquid wastes.
6. **Threat of Environmental Impact.** Threatening, imminent failure of a BMP that has potential for an environmental impact.
7. **Lack of Adequate/Appropriate Controls.** Overall site conditions are such that BMPs are not

effectively installed or implemented as required.

The City issues all Enforcement Actions via e-mail and will follow up as necessary with a certified mail copy. The City shall track the receipt and response to the Enforcement Action. After the City has issued an Enforcement Action, there are procedures which must be followed in order to resolve the Enforcement Action. Based on the violation(s) that triggered the Enforcement Action, the City will provide specific directives that are typically on the second page of the Enforcement Action. For example, if COA interactions with site personnel (that are responsible for stormwater management on the site) reveal that they are not adequately trained or poorly informed on stormwater requirements, the City may require stormwater training for these site personnel. All NOV's will generally require the following procedures for resolution:

- **Contact** the COA upon receipt of the NOV
- **Submittal** of a Remediation and/or Action Plan for review and approval by the City. The submitted Plan should specifically address all areas that were found in violation in the NOV and the SMEC Report. Specific requirements for Plan narratives will be detailed in the NOV
- **Execution of the Plan(s)** when approved by the City
- **Receive a passing, follow-up inspection** by the City, upon completion of all items noted in the NOV and accompany SMEC Report.

At the time an Enforcement Action is issued, the City may choose to withhold City services. When the Enforcement Action is issued, a deadline will be provided to complete all necessary remediation and action items. The timeframes may vary depending on the seriousness of the NOV. Failure to adequately address all findings within the allotted time-frame may result in revocation of the site's Stormwater Permit, issuance of a Stop Work Order, or further criminal or civil enforcement action. The Enforcement Action shall remain open until the recipient receives written notification from the City that all concerns have been resolved and the Enforcement Action is closed. Failure to adequately address the Enforcement Action findings in a timely fashion and/or repeated enforcement action may result in City services being withheld from the site after the Enforcement Action is released. This Environmental Hold may require site inspections to verify compliance prior to the release of water meters and/or building permits. Only when a history of compliance is established, through a series of random inspections, will the hold be released.

THIS PAGE IS INTENTIONALLY BLANK

Appendix H – Colorado Noxious Weeds List

This list is provided as a courtesy and is intended to be used as a guide for Landowners, Developers and Contractors to identify noxious weeds on project sites and to take measures to control the weeds in the early stages of establishment.

THIS PAGE IS INTENTIONALLY BLANK

Colorado's Noxious Weed List

The Colorado Noxious Weed Act and supporting Rules establish a prioritized list of noxious weeds. For detailed information visit the State's site.

A List

List A species are invasive weeds that are either not known to occur in Colorado or are of very limited distribution and are required to be eradicated.

African rue (*Peganum harmala*)
Camelthorn (*Alhagi pseudalhagi*)
Common crupina (*Crupina vulgaris*)
Cypress spurge (*Euphorbia cyparissias*)
Dyer's woad (*Isatis tinctoria*)
Giant salvinia (*Salvinia molesta*)
Hydrilla (*Hydrilla verticillata*)
Meadow knapweed (*Centaurea pratensis*)
Mediterranean sage (*Salvia aethiopsis*)
Medusahead (*Taeniatherum caput-medusae*)
Myrtle spurge (*Euphorbia myrsinites*)
Orange hawkweed (*Hieracium aurantiacum*)
Purple loosestrife (*Lythrum salicaria*)
Rush skeletonweed (*Chondrilla juncea*)
Sericea lespedeza (*Lespedeza cuneata*)
Squarrose knapweed (*Centaurea virgata*)
Tansy ragwort (*Senecio jacobaea*)
Yellow starthistle (*Centaurea solstitialis*)

B List

List B species are invasive weeds with populations of varying distribution and densities within the state. The level of mandated control is based on local conditions. These weeds may require eradication within certain areas of the state.

Absinth wormwood (*Artemisia absinthium*)
Black henbane (*Hyoscyamus niger*)
Bouncingbet (*Saponaria officinalis*)
Bull thistle (*Cirsium vulgare*)
Canada thistle (*Cirsium arvense*)
Chinese clematis (*Clematis orientalis*)
Common tansy (*Tanacetum vulgare*)
Common teasel (*Dipsacus fullonum*)
Corn chamomile (*Anthemis arvensis*)
Cutleaf teasel (*Dipsacus laciniatus*)
Dalmatian toadflax, broad-leaved (*Linaria dalmatica*)
Dalmatian toadflax, narrow-leaved (*Linaria genistifolia*)
Dame's rocket (*Hesperis matronalis*)
Diffuse knapweed (*Centaurea diffusa*)
Eurasian watermilfoil (*Myriophyllum spicatum*)
Hoary cress (*Cardaria draba*)
Houndstongue (*Cynoglossum officinale*)
Jointed goatgrass (*Aegilops cylindrica*)
Leafy spurge (*Euphorbia esula*)

Mayweed chamomile (*Anthemis cotula*)
Moth mullein (*Verbascum blattaria*)
Musk thistle (*Carduus nutans*)
Oxeye daisy (*Chrysanthemum leucanthemum*)
Perennial pepperweed (*Lepidium latifolium*)
Plumeless thistle (*Carduus acanthoides*)
Quackgrass (*Elytrigia repens*)
Russian knapweed (*Acroptilon repens*)
Russian-olive (*Elaeagnus angustifolia*)
Salt cedar (*Tamarix chinensis*, *T. parviflora*, and *T. ramosissima*)
Scentless chamomile (*Matricaria perforata*)
Scotch thistle (*Onopordum acanthium*)
Scotch thistle (*Onopordum tauricum*)
Spotted knapweed (*Centaurea maculosa*)
Spurred anoda (*Anoda cristata*)
Sulfur cinquefoil (*Potentilla recta*)
Venice mallow (*Hibiscus trionum*)
Wild caraway (*Carum carvi*)
Yellow nutsedge (*Cyperus esculentus*)
Yellow toadflax (*Linaria vulgaris*)

C List

List C species are widespread and common within the state. They may pose a risk to agricultural lands and may be required to be controlled.

Chicory (*Cichorium intybus*)
Common burdock (*Arctium minus*)
Common mullein (*Verbascum thapsus*)
Common St. Johnswort (*Hypericum perforatum*)
Downy brome (*Bromus tectorum*)
Field bindweed (*Convolvulus arvensis*)
Halogeton (*Halogeton glomeratus*)
Johnsongrass (*Sorghum halepense*)
Perennial sowthistle (*Sonchus arvensis*)
Poison hemlock (*Conium maculatum*)
Puncturevine (*Tribulus terrestris*)
Velvetleaf (*Abutilon theophrasti*)
Wild proso millet (*Panicum miliaceum*)

Appendix I – Reserved

This Appendix is reserved for future use.

THIS PAGE IS INTENTIONALLY BLANK

Appendix J – Reserved

This Appendix is reserved for future use.

THIS PAGE IS INTENTIONALLY BLANK

Appendix K – Cherry Creek Basin Authority Fact Sheets

A portion of the City of Aurora's jurisdiction is also located within the Cherry creek Basin. Certain additional construction stormwater management requirements apply to projects located within the Cherry Creek Basin, pursuant to the Cherry Creek Reservoir Control Regulation (5 CCR 1002-72). The attached fact sheets are published by the Cherry Creek Basin Water Quality Authority. The fact sheets are reproduced here for convenience, and are intended to be used as additional guidance to aid applicants for the City of Aurora Stormwater (Quality) Discharge Permit for Construction Activities in selecting an appropriate and complete system of temporary construction stormwater BMPs for proposed projects located within the Cherry Creek Basin. Form more information and additional guidance for projects located within the Cherry Creek Basin, please visit http://www/cherryvreekbasin.org/cc_sw_contractors.asp

THIS PAGE IS INTENTIONALLY BLANK



What does the Authority look for in a Land Use Application?

1 Who is the Authority?

The Cherry Creek Basin Water Quality Authority (Authority) is a referral agency that will be reviewing your land use application because your development is within the Cherry Creek Reservoir Basin. This referral is to assist local land use agencies in implementing their stormwater requirements and those of the Authority.

The Authority is a quasi-municipal organization and political subdivision of the State that has primary responsibility for water quality in the Cherry Creek Reservoir Basin. The Authority is specifically empowered to develop and implement plans for water quality controls for the Reservoir and watershed.

This fact sheet is part of The BMP Series, a program developed by the Authority to provide education on BMP requirements within the Cherry Creek Reservoir Basin. Authority manager: 303-779-4525

2 What do I need to know?

best management
B: practice = things
M: we can do or build
P: to maintain or improve water quality

The Authority's Requirements*: *For more information, see the Authority's *Cherry Creek Reservoir Watershed Stormwater Quality Requirements*, February 16, 2000

The *Requirements* identify measures to control the quality of stormwater runoff in the Cherry Creek Reservoir Basin from private and public property and to reduce the loads of contaminants reaching Cherry Creek and Cherry Creek Reservoir for the health, safety, and general welfare in the Cherry Creek Reservoir Basin.

What to submit to your land use agency:
Construction BMP Plan (for temporary construction erosion and sediment controls)
Permanent BMP Plan (may be separate document or incorporated with erosion and sediment control or drainage reports)

Must have approval prior to:
Implementation of any BMPs or Commencement of land disturbances

If your property is an **industrial facility**, the Permanent BMP Plan should include additional **Industrial Permanent BMP Requirements***. Contact your planner for specific submittal requirements.



A land disturbance in a **Stream Preservation Area** has **additional requirements***, such as constructed wetland basin or channels. **Stream Preservation Areas** include Cherry Creek Reservoir, all of Cherry Creek State Park, drainage and discharge to the park within 100 feet of the Park Boundary; lands overlying the Cherry Creek alluvium; and all lands within the 100-year floodplain, as defined by Urban Drainage and Flood Control District (UDFCD). (Note: If the specific floodplain for Cherry Creek and its tributaries is not currently mapped by UDFCD, please reference the Requirements* or contact the Authority for assistance in defining the Stream Preservation Area.)

In the event that the BMP measures in these *Requirements** conflict with other state or local drainage or stormwater quality requirements, the most stringent requirements shall govern.



3 What do I need to do about BMPs?

- Give your design engineer a copy of “The BMP Series: FS 5 – A fact sheet for *engineers*” and make sure he or she is aware of the *Requirements** and has the proper reference materials.
- Submit a **Construction BMP Plan** and a **Permanent BMP Plan** before you construct or install any BMPs. You should submit these to the local agency according to their schedule and process, preferably at the earliest feasible review stage so there is time for review and comment. You can consult with your local land use agency and the Authority to explore ideas for BMPs.
- Land use agencies enforce stormwater requirements, so be sure you are in compliance.
- Look for opportunities to participate in **regional facilities** with other developments and developers early in the planning process. Regional facilities may be more cost-effective than individual on-site BMPs and may be integrated into open space, parks, and golf courses. Examples of regional facilities include extended detention ponds, retention ponds, and constructed wetland detention. The Authority supports the use of regional facilities, and will review new or innovative ideas.



(photo courtesy of the Cherry Creek Corridor Major Drainageway Master Plan project)

If the developer participates in a regional facility that provides adequate pollutant removal for the site, the developer may not be required to construct onsite BMPs except if the land disturbance is in a Stream Preservation area.

Regional facilities also provide opportunities to participate in the Authority’s *phosphorus trading program*. Constructing facilities eligible for trading could provide economic benefits to the developer. Contact the Authority for more information.

This fact sheet provides basic information; review the Requirements and your land use agency’s regulations for a complete explanation of all requirements.*

resources

Authority’s *Requirements**
(developing website)

Denver Regional Council of Governments
www.drcoq.org/ 303-455-1000

EPA Stormwater Program, Phase 2
Resources for Colorado
<http://www.cdphe.state.co.us/wq/PermitsUnit/PhIIresource.PDF>

Urban Drainage and Flood Control District
Urban Storm Drainage Criteria Manual Vol 3;
and Flood Hazard Area Delineation, Master
Planning and Construction Map
www.udfcd.org/ 303-455-6277

4 What can BMPs offer me?

- Zoning benefits, tradeoffs on open space requirements, and lot premium.
- Some BMPs are practical and affordable – grass swales are cheaper than curb and gutter.
- Providing BMPs beyond minimum requirements could provide potential phosphorus trading opportunities.
- Opportunities for cost-effective partnering in regional stormwater quality facilities could arise early in the planning process.
- Opportunities to work with Authority’s phosphorus facilitator (contact Authority manager at 303-779-4525 for more information).
- An easier time meeting regulations:
Since the Authority reviews your application, it may save time and money to meet the *Requirements** from the start. And if your local agency has regulations that have been approved by the Authority, [The BMP Series](#) reflects the requirements of the Authority as well as those of that agency; therefore, using these fact sheets may help you to meet your land use agency’s regulations.





Required and Recommended Temporary and Permanent BMPs

1 Who is the Authority?

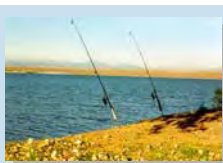

The Cherry Creek Basin Water Quality Authority (Authority) is a referral agency that will be reviewing your land use application because your development is within the Cherry Creek Reservoir Basin. This referral is to assist local land use agencies in implementing their stormwater requirements and those of the Authority.



The Authority is a quasi-municipal organization and political subdivision of the State that has primary responsibility for water quality in the Cherry Creek Reservoir Basin. The Authority is specifically empowered to develop and implement plans for water quality controls for the Reservoir and watershed.

This fact sheet is part of The BMP Series, a program developed by the Authority to provide education on BMP requirements within the Cherry Creek Reservoir Basin. Authority manager: 303-779-4525

*Information presented in this fact sheet is based on the Authority's *Cherry Creek Reservoir Watershed Stormwater Quality Requirements*, February 16, 2000

... best management
B: practice = things
M: we can do or build
P: to maintain or improve water quality

2 What do I need to know?

The Authority's Requirements*.

The *Requirements* identify measures to control the quality of stormwater runoff in the Cherry Creek Reservoir Basin from private and public property and to reduce the loads of contaminants reaching Cherry Creek and Cherry Creek Reservoir for the health, safety, and general welfare in the Cherry Creek Reservoir Basin.

What to submit to your land use agency:
Construction BMP Plan (for temporary construction erosion and sediment controls)
Permanent BMP Plan (may be separate document or incorporated with erosion and sediment control or drainage reports)

Must have approval prior to:
Implementation of any BMPs or Commencement of land disturbances

If your property is an **industrial facility**, the Permanent BMP Plan should include additional **Industrial Permanent BMP Requirements***. Contact your planner for specific submittal requirements.



A land disturbance in a **Stream Preservation Area** has **additional requirements***, such as constructed wetland basin or channels. **Stream Preservation Areas include** Cherry Creek Reservoir, all of Cherry Creek State Park, drainage and discharge to the park within 100 feet of the Park Boundary; lands overlying the Cherry Creek alluvium; and all lands within the 100-year floodplain, as defined by Urban Drainage and Flood Control District (UDFCD). (Note: If the specific floodplain for Cherry Creek and its tributaries is not currently mapped by UDFCD, please reference the Requirements* or contact the Authority for assistance in defining the Stream Preservation Area.)

In the event that the BMP measures in these *Requirements** conflict with other state or local drainage or stormwater quality requirements, the most stringent requirements shall govern.



3 What do I need to do?

Be aware of the **Construction BMPs** and **Permanent BMPs** required for land disturbance and development activities.

Construction BMPs:

It is important to consider site-specific conditions and know which BMPs are appropriate. In addition to guidance from your land use agency on choosing site-specific and appropriate BMPs, UDFCD, *Urban Storm Drainage Criteria Manual, Volume 3* provides detailed guidance on BMP selection, application, limitations, and specifications.



Categories of BMPs In-Place Before Construction

1. Phase construction	Minimize the total amount of soil exposed to reduce accelerated soil erosion.
2. Reduce stormwater runoff flow to non-erosive velocities	Swales, roadside swales, slope diversion dikes, terracing/contouring, slope drains, check dams.
3. Protect drainageways from erosion and sediment damages	Waterway crossing protection, inlet protection, outlet protection, temporary diversions.
4. Control sediment before it leaves construction site	Sediment entrapment: silt fences, filter strips, sediment basins, straw bale barriers; vehicle tracking: grates, vehicle tracking control pads.

Categories of BMPs Installed During Construction

5. Stabilize soils	Mulching, erosion control mats, blankets, and nets, seeding, soil binders, cover crops, surface roughening.
6. Revegetate disturbed soils	Temporary or permanent revegetation (drought alternatives available – consult your planning department).

Permanent BMPs:

Minimum Water Quality Capture Volume (WQCV). For all land disturbances, developers should install and operate Permanent BMPs, or approved combination BMPs, that provide WQCV designed to capture and treat, at a minimum, the 80th percentile runoff event (in accordance with UDFCD Volume 3).

Developers are encouraged to collaborate with other developments to establish **regional facilities**. Regional facilities, which accomplish the WQCV and pollutant removal requirements for all tributary areas, may be:

- more cost-effective than individual-site BMPs,
- integrated into open space, parks, and golf courses, and/or
- useful to offset on-site BMP requirements, except if the land disturbance is in a Stream Preservation Area.

The Authority supports the use of regional facilities, and will review new and innovative ideas.



(courtesy of the Cherry Creek Corridor Major Drainageway Master Plan project)

Permanent BMPs

- Extended-Detention Basins (Dry Ponds)**
- Retention Ponds (Wet Ponds)**
- Constructed Wetlands Basin**
- Porous Pavement Detention
- Porous Landscape Detention
- Sand Filter Extended Detention Basin

**Examples of regional facilities.

Combination BMPs

- Grass swale preceded by porous pavement detention or porous landscape detention.
- Constructed wetland channel preceded by modular block porous pavement.
- Constructed wetland channel, in conjunction with extended detention, basin, retention pond, constructed wetlands basin, porous pavement detention, porous landscape detention, or sand filter extended detention basin.

Constructing BMPs effectively

BMP
best management practice = things we can do or build to maintain or improve water quality

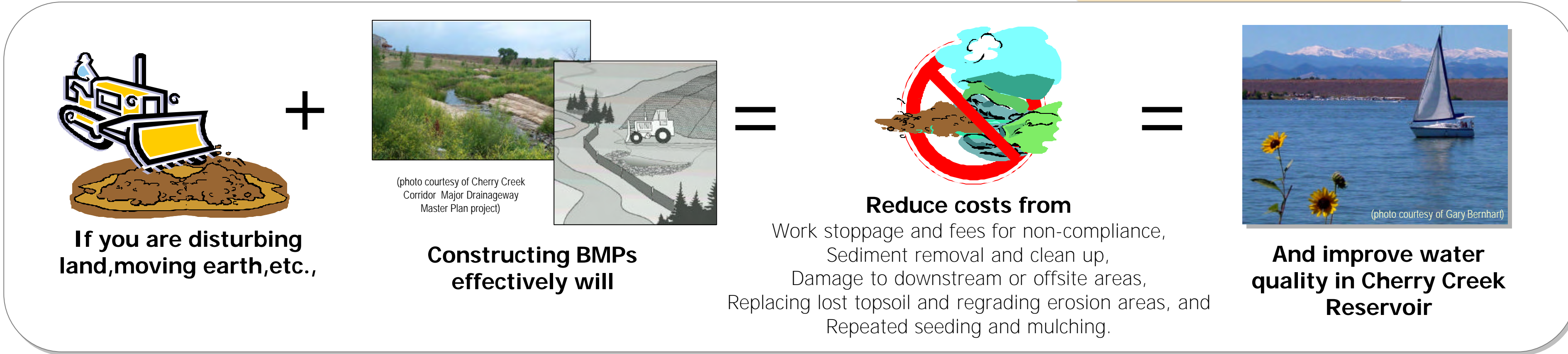

The BMP Series FS 8

This poster is part of The BMP Series, a program developed by the Authority to provide education on BMP requirements within the Cherry Creek Reservoir Basin.
Authority manager: 303-779-4525

Steps to follow:

1. Know which BMPs are needed for the development.
2. Check with local land use agency to confirm rules and regulations.
3. Follow instructions and construct the BMP effectively.
4. Enjoy the reduced cost and added benefit.

DO Examples of effective BMP construction

Potential mistakes DON'T

Construction Fence and Construction Markers
Construction fence consists of orange plastic fencing material attached to support posts and used to control access to the construction site and delineate limits of construction. If appropriate, construction markers, consisting of orange painted survey lath at 100-foot maximum spacing, may be used to delineate limits of construction.

Use construction fence to restrict access to site and delineate limits of disturbance.

DON'T

This construction fence is in need of repair. Inspections shall be made daily and downed sections repaired immediately.

Concrete Washout Area
A concrete washout area is a shallow excavation with a small perimeter berm to isolate concrete truck-wash operations and to help control pollutants from the wash.

A properly installed concrete washout area.

DON'T

Extensive wasting of concrete on the construction site requires additional effort to clean up and can impair subsequent revegetation operations.

Erosion Control Blanket
Erosion control blanket is a fibrous blanket of straw, jute, or coconut material trenched in and staked down over prepared, seeded soil. The blanket reduces both wind and water erosion.

Ample erosion control blanket is used on this hill slope.

DON'T

Failure to utilize an erosion control blanket on this hill slope resulted in extensive erosion. Erosion control blankets should be utilized on slopes steeper than 4:1, after proper soil preparation and seeding has taken place.

Diversion Ditch
A diversion ditch is a small earth channel used to divert and convey runoff, generally to a sediment basin, check dam, or reinforced rock berm. Depending on slope, the diversion swale may need to be lined with erosion control matting, plastic (for temporary installations only), or riprap.

This diversion ditch provides protection for an adjacent drainage.

DO

This plastic lined diversion ditch (or slope drain, shown) or piped slope drain (not shown) may be used as a temporary alternative to a slope drain. Both allow runoff to be conveyed down a slope without causing rill and gully erosion.

DON'T

Lack of a diversion ditch at the top of this slope to divert upstream runoff has led to severe rill and gully erosion.

Check Dam
A check dam is a small rock dam, reinforced or non-reinforced and designed to withstand overtopping, that is placed in a stream or drainage. The purpose of the check dam is to trap sediment in the backwater zone upstream of the check and, when used in series, to reduce flow velocities.

Properly installed non-reinforced check dam.

DO

Properly installed non-reinforced check dam.

DON'T

This disturbed drainage way was not protected by a check dam at the downstream site perimeter, allowing sediment to be conveyed off-site.

Inlet Protection
Inlet protection can consist of a small reinforced rock berm or concrete blocks placed in front of (but not blocking) a curb inlet or around an area inlet to reduce sediment in runoff entering the storm sewer system.

Temporary Inlet Protection
This interim configuration of blocks protects a street inlet prior to paving.

Properly installed inlet protection.

DO

This inlet protection is overdue for sediment removal.

DON'T

Tubular markers were not placed in front of this inlet protection installation, making it more susceptible to damage from snowplows and other vehicles. This installation is in need of immediate repair.

Sediment Basin
A sediment basin is an impoundment that captures sediment-laden runoff and releases water slowly, providing prolonged settling times to capture coarse and fine-grained soil particles.

On a temporary basis, gravel packs can be installed around a sediment basin perforated pipe outlet, but they may cause clogging problems.

DON'T

The sediment basin on the right is improperly installed due to lack of an armored spillway. Pipe perforations set above the spillway crest elevation.

Seeding and Mulching
Seed disturbed areas with seed/grass mix and crimp in straw mulch to provide immediate protection against raindrop and wind erosion and, as the grass cover becomes established, to provide long-term stabilization of exposed soils.

A drill seeder can be used to plant seed.

Seed may be hand broadcast, at twice the drilled rate, raked and crimp mulched in small areas where it is not possible to drill seed.

DON'T

Do not hydroseed and hydromulch as one operation.

Silt Fence
Silt fence is a temporary sediment barrier constructed of woven fabric stretched across supporting posts. The bottom edge of the fabric is placed in an anchor trench that is backfilled with compacted soil.

Properly installed silt fence cannot easily be pulled out of the ground.

Silt fence is to be securely tied into adjacent BMPs such as the sediment control log shown here, or reinforced rock berms or sediment basin embankments.

A reinforced rock berm may be used downgradient of disturbed areas in lieu of silt fence.

DON'T

The lower edge of this silt fence is not anchored in a backfilled trench.

Vehicle Tracking Control Pad
A vehicle tracking control pad consists of crushed aggregate paced in a pad at all entrances/exits on a construction site utilized to remove mud/dirt from the tires of vehicles leaving the site.

Properly installed vehicle tracking pad prevents the spread of mud and dirt from the site to other areas.

DON'T

Failure to utilize a vehicle tracking control pad allowed mud and dirt to be tracked out of this construction site, allowing the material to easily be washed away during a runoff event.

To find out more...

Photos and text for BMPs are courtesy of Douglas County Department of Public Works Engineering Division

Construction BMP training sessions may be offered by your local land use agency. Please contact your local land use agency for information on possible training sessions.

THIS PAGE IS INTENTIONALLY BLANK