

# STANDARDS AND SPECIFICATIONS

## WATER, SANITARY SEWER AND STORM DRAINAGE INFRASTRUCTURE



AURORA  
WATER

---

**THIS PAGE IS INTENTIONALLY BLANK**



**AURORA  
WATER**



**Standards and Specifications Regarding  
Water, Sanitary Sewer and Storm Drainage Infrastructure**

**Including:  
Rules and Regulations Governing  
Wastewater Control**

**Effective Date: January, 2012**

---

Dan Mikesell  
Director  
Aurora Water

**Promulgated pursuant to City of Aurora Code of Ordinances Chapters 138 and 147**

**THIS PAGE IS INTENTIONALLY BLANK**

# TABLE OF CONTENTS

## **SECTION 1.00 INTRODUCTION**

---

1.01 SCOPE	1-1
1.02 AUTHORITY	1-1
1.03 AMENDMENTS, REVISIONS AND UPDATES	1-1
1.04 REVIEW AND APPROVAL	1-1
1.05 CRITICAL INFRASTRUCTURE	1-2
1.06 REGIONAL INFRASTRUCTURE	1-2
1.07 INTERPRETATION	1-2
1.08 DEFINITIONS AND TERMS	1-2

## **SECTION 2.00 GENERAL PROVISIONS**

---

2.01 AUTHORITY OF THE ENGINEER	2-1
2.02 AUTHORITY OF THE INSPECTOR	2-1
2.03 DEFECTIVE MATERIALS AND WORK	2-1
2.04 INSPECTION FACILITIES	2-1
2.05 TRAFFIC CONTROL	2-2
2.06 UTILITIES COORDINATION	2-2
2.07 STORM WATER QUALITY	2-2
2.08 DAMAGES	2-2
2.09 PROTESTS	2-3

## **SECTION 3.00 PERMITS, EXTENSION AGREEMENTS, INSPECTIONS AND ACCEPTANCE OF WORK**

---

3.01 PUBLIC EXTENSION AGREEMENTS AND PERMITS	3-1
3.02 PRIVATE EXTENSION PERMITS	3-1
3.03 UTILITY MAIN CONSTRUCTION	3-2
3.04 WATER SERVICES	3-3
3.05 CONSTRUCTION INSPECTIONS	3-4
3.06 INITIAL ACCEPTANCE FOR UTILITIES	3-4
3.07 WARRANTY PERIOD	3-5
3.08 FINAL ACCEPTANCE FOR UTILITIES	3-5

## **SECTION 4.00 JOB SITE SAFETY, HEALTH AND ENVIRONMENTAL REQUIREMENTS**

---

4.01 OCCUPATIONAL SAFETY AND HEALTH	
ADMINISTRATION	4-1
4.02 PROTECTION OF WORK AND PROPERTY	4-1
4.03 ACCIDENT PREVENTION	4-1
4.04 SANITARY REGULATIONS	4-2
4.05 PREVENTION OF WATER POLLUTION	4-2
4.06 DEWATERING	4-2
4.06 ABATEMENT OF AIR POLLUTION	4-2
4.07 DUST ABATEMENT	4-3

## **SECTION 5.00 UTILITY DESIGN CRITERIA AND CONSTRUCTION PLANS**

---

5.01 GENERAL	5-1
5.02 WATER DISTRIBUTION LINES DESIGN CRITERIA	5-1
5.03 SANITARY SEWER SYSTEM DESIGN CRITERIA	5-3
5.04 ALIGNMENT, DEPTH AND EASEMENTS	5-6
5.05 CIVIL CONSTRUCTION PLAN REQUIREMENTS	5-7
5.06 MANHOLE SPACING	5-12
5.07 BARREL SIZE	5-12
5.08 IRRIGATION PLANS	5-13

## **SECTION 6.00 PROTECTION OF EXISTING FACILITIES**

---

6.01 GENERAL	6-1
6.02 CONCRETE WORK	6-1
6.03 PAVEMENT REPLACEMENT	6-2
6.04 UNDERGROUND UTILITIES	6-2

## **SECTION 7.00 MATERIAL HANDLING AND STORAGE**

---

7.01 GENERAL	7-1
7.02 MATERIALS HANDLING	7-1
7.03 MATERIALS STORAGE	7-1

## **SECTION 8.00 EXCAVATION**

---

8.01 GENERAL	8-1
8.02 TRENCH EXCAVATION	8-1
8.03 TRENCH SIDE WALLS	8-1
8.04 SHORING	8-2
8.05 ROCK EXCAVATION	8-2
8.06 BLASTING	8-2
8.07 PAVEMENT REMOVAL	8-3
8.08 PREPARATION FOR PIPE LAYING	8-3

## **SECTION 9.00 PIPE BEDDING, BACKFILLING AND COMPACTION**

---

9.01 GENERAL	9-1
9.02 GRANULAR BEDDING MATERIAL	9-2
9.03 COMPACTING GRANULAR BEDDING	9-2
9.04 COMPACTION OF ORDINARY BACKFILL MATERIAL WITHIN THE BEDDING SECTION	9-3
9.05 CLASSES OF BEDDING	9-3
9.06 ORDINARY BACKFILL MATERIAL	9-4
9.07 SELECT BACKFILL MATERIAL	9-4
9.08 COMPACTING GRANULAR BACKFILL MATERIAL	9-4
9.09 COMPACTING ORDINARY MATERIAL	9-5
9.10 COMPACTION TESTING	9-5
9.11 MAINTENANCE OF BACKFILL	9-6
9.12 CONSTRUCTION SITE RESTORATION	9-6

## **SECTION 10.00 MANHOLES, VAULTS AND INLETS**

---

10.01 MATERIALS	10-1
10.02 CONSTRUCTION	10-3
10.03 MANHOLE BASES AND CHANNELS	10-4
10.04 HORIZONTAL JOINTS	10-4
10.05 EXISTING MANHOLES	10-5
10.06 WATER SYSTEM MANHOLES AND VAULTS	10-5
10.07 SANITARY SEWER SYSTEM MANHOLES	10-5

## **SECTION 10.00 MANHOLES, VAULTS AND INLETS (cont.)**

---

10.08 STORM SEWER SYSTEM MANHOLES AND INLETS	10-6
10.09 REFERENCE MARKERS	10-6

## **SECTION 11.00 WATER PIPE INSTALLATION**

---

11.01 GENERAL	11-1
11.02 PROGRESSION OF WORK	11-1
11.03 ALIGNMENT	11-1
11.04 EXCAVATION BEDDING AND BACKFILLING	11-2
11.05 FITTINGS AND SPECIALS	11-2
11.06 WET TAPS	11-2
11.07 RUBBER GASKET JOINTS	11-3
11.08 CRADLES AND ENCASEMENTS FOR UTILITY CROSSINGS	11-3
11.09 THRUST RESTRAINT	11-4
11.10 THRUST BLOCKS	11-4
11.11 CORROSION PROTECTION	11-5
11.12 DISINFECTION OF WATER LINES	11-5
11.13 FLUSHING THE LINE	11-8
11.14 PRESSURE TEST	11-9

## **SECTION 12.00 DUCTILE IRON (DIP) WATER LINE**

---

12.01 GENERAL	12-1
12.02 DIAMETER OF PIPE	12-1
12.03 PRESSURE CLASS DESIGN OF PIPE	12-1
12.04 GRADE OF IRON	12-1
12.05 PIPE LENGTHS	12-1
12.06 FITTINGS AND SPECIALS	12-1
12.07 FIELD JOINTS	12-2
12.08 PROTECTIVE COATINGS	12-2
12.09 CATHODIC PROTECTION	12-2
12.10 INSTALLATION	12-3



## **SECTION 13.00 STEEL WATER LINE**

---

13.01 GENERAL	13-1
13.02 DIAMETER OF PIPE	13-1
13.03 WALL THICKNESS DESIGN OF PIPE	13-1
13.04 GRADE OF STEEL	13-1
13.05 SHOP TEST PRESSURE	13-1
13.06 LINING	13-1
13.06 FITTINGS AND SPECIALS	13-2
13.07 FIELD JOINTS	13-2
13.08 INSTALLATION	13-3
13.09 CATHODIC PROTECTION	13-4

## **SECTION 14.00 POLYVINYL CHLORIDE (PVC) WATER LINE**

---

14.01 GENERAL	14-1
14.02 MATERIALS	14-1
14.03 FITTINGS AND SPECIALS	14-1
14.04 DIAMETER OF PIPE	14-1
14.05 STORAGE OF PIPE	14-1
14.06 SUNBURNED PIPE	14-2
14.07 INSTALLATION	14-2

## **SECTION 15.00 WATERLINE VALVES**

---

15.01 GENERAL	15-1
15.02 INSTALLATION	15-1
15.03 GATE VALVES	15-1
15.04 BUTTERFLY VALVES	15-1
15.05 PRESSURE REDUCING AND REGULATING VALVES	15-2
15.06 CHECK VALVES	15-3
15.07 AIR AND VACUUM VALVES	15-3
15.08 BLOW-OFF VALVES	15-3
15.09 VALVE BOXES	15-4
15.10 VALVE VAULTS	15-4
15.11 REFERENCE MARKERS	15-4

## **SECTION 16.00 FIRE HYDRANTS**

---

16.01 GENERAL	16-1
16.02 HYDRANT DETAILS	16-1
16.03 INSTALLATION	16-1
16.04 TESTING	16-2
16.05 FIRE HYDRANT LOCATION	16-2
16.06 FIRE HYDRANT SPACING	16-4
16.07 RELOCATIONS	16-4

## **SECTION 17.00 WATER SERVICE LINES**

---

17.01 GENERAL	17-1
17.02 LOCATION AND ALIGNMENT OF SERVICE	17-1
17.03 MATERIALS	17-1
17.04 CROSSING OF SIDEWALK OR CURB	17-2
17.05 SERVICE STUB-INS	17-2
17.06 TAPPING THE MAIN	17-2
17.07 SERVICE LINE INSTALLATIONS	17-2
17.08 METER PIT INSTALLATIONS	17-3
17.09 MULTI-FAMILY METER INSTALLATIONS	17-4
17.10 RE-USE AND RELOCATION OF EXISTING METER PITS	17-4
17.11 DISCONTINUATION OF WATER SERVICE	17-5

## **SECTION 18.00 AUTOMATIC FIRE SUPPRESSION SYSTEM WATERLINES**

---

18.01 OWNERSHIP	18-1
18.02 INSTALLATION	18-1
18.03 TESTING	18-2

## **SECTION 19.00 BACKFLOW PREVENTION ASSEMBLIES**

---

19.01 GENERAL	19-1
19.02 IRRIGATION SYSTEMS	19-2
19.03 FIRE SUPPRESSION SYSTEMS	19-3
19.04 INSTALLATION	19-4

## **SECTION 19.00 BACKFLOW PREVENTION ASSEMBLIES (cont.)**

---

19.05 TESTING AND REPORTING	19-6
-----------------------------	------

## **SECTION 20.00 CORROSION CONTROL FOR WATER PIPE**

---

20.01 SOIL RESISTIVITY MEASUREMENTS	20-1
20.02 ANODE AND TEST SITE INSTALLATION	20-1
20.03 CORROSION CONTROL FOR SPECIAL SITUATIONS AND APPURTENENCES	20-3
20.04 CORROSION DESIGN FOR 16 INCHES AND LARGER DIP AND STEEL LINES	20-5
20.05 DUCTILE IRON PIPE	20-5
20.06 STEEL PIPE	20-6
20.07 ELECTRICAL GROUNDING AND HIGH VOLTAGE POWER	20-7

## **SECTION 21.00 SANITARY SEWER PIPE INSTALLATION**

---

21.01 GENERAL	21-1
21.02 PROGRESSION OF WORK	21-1
21.03 LINE AND GRADE	21-1
21.04 CRADLES AND ENCASEMENTS	21-1
21.05 TEES, WYES, AND RISERS	21-1
21.06 CLEANING THE LINE	21-2
21.07 TESTING AND INSPECTION	21-2

## **SECTION 22.00 POLYVINYL CHLORIDE (PVC) GRAVITY SEWER LINE**

---

22.01 GENERAL	22-1
22.02 DIAMETER OF PIPE	22-1
22.03 WALL THICKNESS DESIGN OF PIPE	22-1
22.04 FITTINGS AND SPECIALS	22-1
22.05 JOINTS	22-1
22.06 PIPE LENGTHS	22-1
22.07 MARKINGS ON PIPE	22-2

## **SECTION 23.00 SANITARY SEWER SERVICE LINE CONSTRUCTION**

---

23.01 GENERAL	23-1
23.02 MATERIALS	23-1
23.03 LOCATION AND ALIGNMENT OF SERVICE	23-1
23.04 SERVICE LINE INSTALLATIONS	23-1
23.05 TAPPING THE MAIN	23-2
23.06 CLEAN OUTS	23-4
23.07 SERVICE STUB-IN TO PROPERTY LINE	23-4
23.08 SIDEWALK OR CURB CROSSING	23-4
23.09 TRENCH BACKFILLING	23-4
23.10 INSPECTION	23-4
23.11 MAINTENANCE OF TRAFFIC	23-5
23.12 WARRANTY OF WORK	23-5
23.13 DISCONTINUATION OF SEWER SERVICE	23-5

## **SECTION 24.00 UNDERDRAIN PIPE**

---

24.01 GENERAL	24-1
24.02 PVC PIPE	24-1
24.03 HDPE PIPE	24-1
24.04 BEDDING	24-1
24.05 ALIGNMENT	24-2
24.06 UNDERDRAIN CLEAN OUTS	24-2

## **SECTION 25.00 STORM SEWER PIPE INSTALLATION**

---

25.01 GENERAL	25-1
25.02 APPROVED PIPE MATERIALS	25-2
25.03 PIPE SIZE	25-2
25.04 EXCAVATION	25-2
25.05 BEDDING	25-2
25.06 INSTALLATION	25-3
25.07 BACKFILL AND COMPACTION	25-3

## **SECTION 26.00 REINFORCED CONCRETE (RCP) STORM SEWER PIPE**

---

26.01 GENERAL	26-1
26.02 CEMENT	26-1
26.03 FITTING AND SPECIALS	26-1
26.04 LIFTING HOLES	26-1
26.05 ACCEPTANCE OF PIPE FOR CONSTRUCTION	26-1
26.06 MARKING	26-2
26.07 JOINTS	26-2
26.08 PIPE SELECTION CHART	26-4

## **SECTION 27.00 ALUMINIZED STEEL (ASP) STORM SEWER PIPE**

---

27.01 GENERAL	27-1
27.02 WALL THICKNESS AND GAGE	27-1
27.03 PIPE SEAMS AND ENDS	27-1
27.04 FITTINGS AND SPECIALS	27-1
27.05 PROTECTIVE COATINGS	27-2
27.06 COUPLING BANDS	27-2
27.07 PIPE SELECTION CHART	27-3

## **SECTION 28.00 POLYVINYL CHLORIDE (PVC)STORM SEWER PIPE**

---

28.01 GENERAL	28-1
28.02 PIPE AND FITTINGS	28-1
28.03 JOINTS	28-1
28.04 FITTINGS AND SPECIALS	28-1
28.05 PIPE SELECTION CHART	28-2

## **SECTION 29.00 HIGH DENSITY POLYETHYLENE (HDPE) STORM SEWER PIPE**

---

29.01 GENERAL	29-1
29.02 BEDDING MATERIAL	29-1
29.03 PIPE AND FITTING MANUFACTURING	29-1
29.04 DIAMETER OF PIPE	29-1

**SECTION 29.00 HIGH DENSITY POLYETHYLENE (HDPE) STORM  
SEWER PIPE (cont)**

---

29.05 JOINTS	29-1
29.06 PIPE SELECTION CHART	29-2

**SECTION 30.00 OPEN CHANNELS AND PONDS**

---

30.01 GENERAL	30-1
30.02 ACCESS	30-1
30.03 LANDSCAPING	30-2
30.04 ACCEPTANCE	30-2

**APPENDIX A – DETAILS**

**APPENDIX B – APPROVED MATERIALS LIST**

**APPENDIX C – RULES AND REGULATIONS REGARDING  
WASTEWATER CONTROL**

**APPENDIX D – IRRIGATION SYSTEM STANDARDS AND  
INSPECTIONS**

## **SECTION 1.00 INTRODUCTION**

- 1.01 SCOPE
- 1.02 AUTHORITY
- 1.03 AMENDMENTS, REVISIONS AND UPDATES
- 1.04 REVIEW AND APPROVAL
- 1.05 CRITICAL INFRASTRUCTURE
- 1.06 REGIONAL INFRASTRUCTURE
- 1.07 INTERPRETATION
- 1.08 DEFINITIONS AND TERMS

## **SECTION 1.00 INTRODUCTION**

### **1.01 Scope**

This volume, entitled Standards and Specifications Regarding Water, Sanitary Sewer and Storm Drainage Infrastructure sets forth the minimum acceptable criteria for public and private utilities and facilities within the City of Aurora. Deviations or variances from these standards may be considered; however, it shall be the responsibility of the applicant to demonstrate to the satisfaction of the Director of Aurora Water or his authorized representative the proposed variance meets or exceeds the minimum acceptable criteria. See Section 5.01 of these specifications for variance procedures. Any proposed waiver of a City Code provision may only be made according to the procedures set forth in the City Code. Policies and technical criteria not specifically addressed in this document shall follow the provisions of the latest editions of the American Water Works Association (AWWA), American Society of Civil Engineers (ASCE), and Urban Drainage and Flood Control District (UDFCD).

### **1.02 Authority**

Portions of the Aurora City Code most often consulted in this volume include Chapter 138 Articles IV – VII.

### **1.03 Amendments, Revisions and Updates**

Amendments, revisions and updates to these Specifications, including Appendix A: Details, Appendix B: Approved Materials List, Appendix C: Rules and Regulations Regarding Wastewater Control, and Appendix D: Irrigation Systems Standards and Specifications may be adopted annually and as often as needed. It is the responsibility of the Consultant/Contractor/Developer/Builder to obtain the latest document(s) from the City. All documents available at [www.auroragov.org](http://www.auroragov.org) shall be considered the latest version..

### **1.04 Review and Approval**

City staff will review all submittals for general compliance with these Specifications. However, approval by the City does not relieve the owner, engineer, or designer from the responsibility of insuring their calculations, plans, specifications, construction and as-built drawings are correct and in compliance with these Specifications. City of Aurora assumes no responsibility or liability for the accuracy or adequacy of the design submittal.



## 1.05 Critical Infrastructure

Aurora Water reserves the right to design and install infrastructure which is determined to be critical by the Engineer for the operation or extension of the City's water, sanitary sewer or storm drainage systems.

## 1.06 Regional Infrastructure

Infrastructure determined to be regional infrastructure by the Engineer shall require pre-qualification of contractors by the City. Regional infrastructure shall include at minimum water mains greater than 12 inches in diameter, sewer lines greater than 15 inches and diameter, and storm drainage infrastructure as determined by the Engineer.

## 1.07 Interpretation

In the interpretation and application of the provisions of these Specifications, the following shall govern:

- These Specifications shall be regarded as the **minimum requirements** needed for the protection of the health, safety, and welfare of the people of Aurora, and shall be liberally construed to further such purposes.
- Whenever these Specifications and any other law, ordinance, resolution, rule, or regulation of any kind contain any restrictions covering any of the same subject matter, whichever standards are more restrictive shall govern.
- These Specifications shall not abrogate or annul any permits and plans issued and approved, respectively prior to these standards effective date, or any final plat documents that have been recommended for approval by the Planning Commission prior to the effective date of these standards.

## 1.08 Definitions and Terms

Wherever in these Specifications or on the submitted drawings the following terms, acronyms, or pronouns in place of them are used, the intent and meaning shall be interpreted as follows:

<b>1.08.1</b>	<b>Associations</b>
ASCE	American Society of Civil Engineers
ASTM	American Society for Testing and Materials
AWWA	American Water Works Association

CDOT	Colorado Department of Transportation
CDPHE	Colorado Department of Public Health and Environment
COA	City of Aurora
FEMA	Federal Emergency Management Association
IBC	International Building Code
IPC	International Plumbing Code
IRC	International Residential Code
ISO	Insurance Service Office, Inc
NFPA	National Fire Protection Association
TCH	Tri-County Health
UPC	Uniform Plumbing Code
UDFCD	Urban Drainage and Flood Control District
WEF	Water Environment Federation

**1.08.2 Other Abbreviations**

ACP	Asbestos Cement Pipe
BFE	Base Flood Elevation
C & G	Curb and Gutter
CIP	Cast Iron Pipe
COI	Curb Opening Inlet
CSP	Corrugated Steel Pipe
DIP	Ductile Iron Pipe
HDPE	High Density Polyethylene Pipe
MH	Manhole
PCR	Point of Curb Return
PVC	Polyvinyl Chloride Pipe
RCP	Reinforced Concrete Pipe
ROW	Right-of-Way
VCP	Vitrified Clay Pipe

**1.08.3 Definitions**

AURORA WATER/WATER DEPARTMENT shall mean the City of Aurora’s utility enterprise responsible for water, sanitary sewer and storm drain infrastructure.

CITY shall mean the City of Aurora, Colorado, a home rule municipal corporation of the Counties of Adams, Arapahoe, and Douglas, sometimes acting by and through its Utilities Enterprise.

CITY CODE shall mean the duly adopted City Code of the City of Aurora, Colorado, as amended.

CONTRACTOR shall mean an individual or other person or entity licensed and bonded as a contractor in the City in accordance with the City Code.

ENGINEER shall mean an authorized representative of Aurora Water Engineering.

EXPRESSIONS Wherever the words, "as directed", "as required", "as permitted", or words of like meaning are used, it shall be understood that the direction, requirements, or permission of Aurora Water Engineering is intended. Similarly, the words "approved", "acceptable", "satisfactory" shall refer to approval by Aurora Water Engineering. Whenever the words "these Specifications" are used it shall be understood that reference is made to Aurora Water's Standards and Specifications Regarding Water, Sanitary Sewer and Storm Drainage Infrastructure including all parts, supplements, and revisions pertaining thereto.

PUBLIC IMPROVEMENTS include: all work in the public right-of-way or in or on City property, easements dedicated to the City, private property that will become City property or an easement to the City in the future, and all other projects or utilities that are or that will become the City's responsibility to maintain.

PRIVATE CONSTRUCTION WORK includes: private sewer systems, storm drainage systems, water and sewer service lines to buildings, grading, drainage structures, retaining walls, parking lots, private streets and walks, fire lanes, driveways, and associated construction outside of the public right-of-way.

SUBCONTRACTOR Any individual or other person or entity licensed and bonded as a contractor in the City in accordance with the City Code which has a direct or indirect contract with the Contractor or other Subcontractor and furnishes and/or performs on-site labor and/or furnishes materials used in connection with the performance of the work.

SURETY shall mean the entity which bonds and guarantees the Contractor's satisfactory performance of the work as described in these specifications. (Bonded)

TESTING AGENCY Any individual or other person or entity which is qualified and licensed to perform the required sampling, analysis, testing, and professional recommendation service.

WATER ENGINEERING INSPECTOR shall mean the authorized representative of the Director of Aurora Water assigned to inspect wet utility infrastructure, heretofore referred to as “Inspector”.

## **SECTION 2.00 GENERAL PROVISIONS**

- 2.01 AUTHORITY OF THE ENGINEER
- 2.02 AUTHORITY OF THE INSPECTOR
- 2.03 DEFECTIVE MATERIALS AND WORK
- 2.04 INSPECTION FACILITIES
- 2.05 TRAFFIC CONTROL
- 2.06 UTILITIES COORDINATION
- 2.07 STORM WATER QUALITY
- 2.08 DAMAGES
- 2.09 PROTESTS

## **SECTION 2.00 GENERAL PROVISIONS**

The provisions stipulated in this section shall be considered as applicable to all parts of these Specifications, including supplements and revisions.

### **2.01 Authority of the Engineer**

The Engineer is designated by the City Manager to exercise all authority on behalf of the City to ascertain all construction of facilities is equal to or better than the minimum construction requirements set forth in these Specifications. The Engineer shall be represented by an Inspector who will check any and all work performed under a permit issued for construction, including all materials to be incorporated in the work, excavation, bedding, backfill, and all construction methods and practices. The Engineer shall have the sole authority to issue, in writing, any deviations from the provisions of these Specifications or changes to any previously approved drawings.

### **2.02 Authority of the Inspector**

Inspectors are assigned by the Engineer to assist the Contractor in complying with these Specifications. Inspectors have the authority to reject inferior materials, defective workmanship and to suspend work which is not in accordance with the City of Aurora Standards and Specifications until such time as the corrections are made and approved.

Water Engineering Inspections must be notified at least twenty-four (24) hours prior to any construction.

### **2.03 Defective Materials and Work**

Whenever materials and/or work are found to be defective, the Contractor, at his expense, shall promptly remove such defective materials and construction from the job site, and replace all defective portions to the satisfaction of the Engineer. In the event the Contractor fails to remove defective items from the job site within 10 days of written notice, the Engineer may arrange for such removal at the expense of the Contractor.

### **2.04 Inspection Facilities**

The Contractor shall furnish all reasonable facilities and shall assist the Inspector, as necessary, for the proper inspection of materials to be used and workmanship involved in the construction.

## **2.05 Traffic Control**

The Contractor is required to implement traffic control per Section 50 of the Roadway Design and Construction Specifications.

## **2.06 Utilities Coordination**

The Contractor shall at all times coordinate his work with the City of Aurora Water Department. When it is necessary to close existing portions of any water or sewer system due to construction operations, at least twenty-four (24) hours prior written notification must be given to the Water Department.

ALL WATER VALVES THAT ARE IN SERVICE SHALL BE OPERATED ONLY BY AUTHORIZED CITY OF AURORA WATER DEPARTMENT PERSONNEL.

Unauthorized operations of the water valves are subject to fines under the City Code Section 138-152. The Contractor shall conduct his operations in such a manner as to minimize inconvenience to the public due to disconnected utility services. Should it become necessary to temporarily disconnect any utility, the Contractor shall first obtain the approval of the City of Aurora Water Department. Such utility shall not be disconnected prior to 9:00 a.m. and shall be restored to full operation no later than 4:00 p.m. the same day. If the Contractor's operations require or cause the utility service to be disconnected beyond the limits stated above, he shall make arrangements suitable to the Engineer to provide temporary utility service or adjust work hours. Such temporary services shall be at the Contractor's expense. In the event a utility is disconnected beyond the hours stated above, the Engineer shall have the authority to order a temporary utility service installed either by City personnel or by a third party at the Contractor's expense.

## **2.07 Storm Water Quality**

The Contractor shall conform to the City of Aurora Rules and regulations Regarding Stormwater Discharges Associated with Construction Activities, latest revision, at all times.

## **2.08 Damages**

The Contractor shall indemnify and hold harmless the City of Aurora, its officers and employees against all suits or actions of any kind and nature brought or which may be brought, or sustained by any person, firm, or corporation or persons, firms, or corporations, in connection with or on account of the Contractor's work or in consequence of any negligence in connection with same, or on account of any poor workmanship, or on account of any act of commission or omission of the Contractor or his, its, or their agent or employees, or for any cause arising during the course

of construction.

## **2.09 Protests**

If the Contractor considers any work demanded of him by the Inspector to be outside the requirements of these Specifications, he shall immediately ask for a written decision or instructions and shall proceed to perform the work to conform with the Inspector's ruling. If the Contractor considers such instructions unsatisfactory, he shall, within twenty-four (24) hours after their receipt, file a written protest with the Engineer, stating his objections and the reasons therefore. Unless protests or objections are made in the manner specified and within the time limits stated herein, the Contractor hereby waives all grounds for protests.



**SECTION 3.00 PERMITS, EXTENSION AGREEMENTS, INSPECTIONS  
AND ACCEPTANCE OF WORK**

- 3.01 PUBLIC EXTENSION AGREEMENTS AND PERMITS
- 3.02 PRIVATE EXTENSION PERMITS
- 3.03 UTILITY MAIN CONSTRUCTION
- 3.04 WATER SERVICES
- 3.05 CONSTRUCTION INSPECTIONS
- 3.06 INITIAL ACCEPTANCE FOR UTILITIES
- 3.07 WARRANTY PERIOD
- 3.08 FINAL ACCEPTANCE FOR UTILITIES

## **SECTION 3.00 PERMITS, EXTENSION AGREEMENTS, INSPECTIONS AND ACCEPTANCE OF WORK**

### **3.01 Public Extension Agreements and Permits**

**3.01.1** The City of Aurora Water Department requires a Public Extension Agreement be signed by the owner/developer for all public utility system installation or abandonment. Engineering drawings in accordance with these Specifications must be submitted to the City of Aurora Public Works Engineering Services Division for approval. When the drawings have been approved, the Applicant obtains and returns signed agreements to the Water Engineering Division. Public Extension Permits will be issued by Water Engineering within 2 working days. The Water Engineering Inspector must be notified at least twenty-four (24) hours in advance of the time construction will begin. The Water Engineering Inspector must be notified and be present when construction commences.

**3.01.2** When Water Engineering Inspectors or other City personnel are required to work overtime or on legal holidays (New Year's Day, Martin Luther King JR. Day, Presidents Day, Memorial Day, Independence Day, Labor Day, Veterans Day, Thanksgiving Day, the Friday after Thanksgiving Day and Christmas Day) it shall be at the Contractor's expense. Water Engineering Inspectors normally work an 8 hour day from 8:00 a.m. to 4:00 p.m. Monday through Friday. Other days or hours shall be considered overtime and shall be at the Contractor's expense. A minimum charge of 4 hours shall be charged for any overtime work requested and performed on weekends and legal holidays. The Contractor's payment for all overtime work shall be made by check to the City of Aurora at the Tap Applications Counter at Aurora Municipal Center, 15151 East Alameda Parkway, Aurora, Colorado.

### **3.02 Private Extension Permits**

**3.02.1** Private Extension Permits are required for the repair or construction of any private water service, fire suppression, sanitary sewer service or storm sewer line or appurtenance. Permits shall be obtained before any work is authorized or allowed. Permits shall be issued only to the contractor actually performing the work and licensed and bonded within the City for the type of work proposed.

**3.02.2** Private Extension Permits are issued only after the City Engineer and the Water Department Engineering Division have approved the plans for the specific improvements to be constructed and all applicable fees have been paid. New construction plans must be

reviewed and approved per Public Works Roadway Design and Construction Specifications, latest revision. Water Engineering may at its discretion approve plans solely for service connections and fire suppression lines or replacement in kind without approval by the City Engineer. Emergency repairs do not require an approved plan, however still require permitting.

**3.02.3** A complete set of approved drawings, specifications, and a valid permit shall be on the job site and available to the Water Engineering Inspector at all times.

### **3.03 Utility Main Construction (Water Distribution, Sanitary Sewer and Storm Drainage)**

**3.03.1** All Public Extension Permits, per Section 3.01, are required prior to starting construction. Developers must have a signed Public Extension Agreement, approved drawings, and any inspection fees paid BEFORE Extension Permits can be issued. Public Extension Agreement and approved plans must be on-site at all times.

**3.03.2** A Water Engineering Inspector must be present with a copy of the approved drawings and the Public Extension Permit when construction first commences. The inspection schedule shall be arranged at this time. Work done without Water Engineering Inspector approval may be cause to have the work removed and redone. All work must meet the Inspector's approval prior to the contractor scheduling "Initial Acceptance" inspections (See Section 4.00). Any deviation from the approved drawings must be approved by Water Engineering, Life Safety and Engineering Divisions through the Water Engineering Inspector prior to construction.

**3.03.3** Utility mains shall be grade staked if overlot grading operations have not been completed.

**3.03.4** Construction must be in accordance with these Specifications. These Specifications are obtainable from the Permit Center, 2nd Floor, Aurora Municipal Building, 15151 East Alameda Parkway or on-line at [www.auroragov.org](http://www.auroragov.org).

**3.03.5** The backfill must pass compaction tests as specified in the Public Works Roadway Design and Construction Specifications, Section 32. Compaction test reports are to be submitted to the City Materials Testing Laboratory.

**3.03.6** A "Notice of Initial Acceptance" is issued to the developer when construction is complete and has passed all testing requirements. See Section 3.06 of these Specifications for additional information.

### **3.04 Water Services**

**3.04.1** All permits, per Section 3.02, are required prior to starting construction of water services.

**3.04.2** Prior to water meter setting, the water service connection, sanitary sewer connection and Metro Wastewater District fees must be paid at the Permit Center at 15151 E Alameda Parkway, Aurora, CO 80012 Suite 2400.

**3.04.3** Water mains shall have been inspected and initially accepted by the Water Engineering Inspector prior to installation of any service taps on the line. A \$100 stub-in fee is required to be paid prior to tapping the water service. This fee is applied to the water service connection fee.

**3.04.4** The Contractor may proceed with installation of 2 inch and smaller water taps on the pressurized main only after testing, Initial Acceptance, and payment of the water service connection fee or stub-out fee. The contractor shall supply the corporation stop with service insulator for a direct tap. The Water Engineering Inspector shall inspect the corporation stop and the service line from the main to the building, for all water service taps, prior to the contractor backfilling the service line trench. The Water Department shall perform all 3 inch and larger water taps on the main at a prearranged time. At the time the tap is made, the service trench must be excavated from the main to the meter pit location.

**3.04.5** If any grade changes occur during the initial warranty period, it shall be the owner/contractors responsibility to adjust service laterals and meter pits to proper depth or grade according to these Specifications. The Contractor shall be responsible for maintenance of the entire line during the period from initial warranty to Final Acceptance. The warranty period shall not be less than one year. The City will be responsible for maintenance of the line from the main to and including the meter only after Final Acceptance has been issued by the City of Aurora.

### **3.05 Construction Inspections**

**3.05.1** The Contractor shall obtain the Water Engineering Inspector's approval of any material before placement and before beginning any work. Grade staking shall be required for utility main construction if overlot grading operations have not been completed.

**3.05.2** The Contractor shall call for all inspections providing a minimum of 24 hours prior notice. Inspections may be requested at (303) 739-7385.

**3.05.3** In the event any of the work or material fails to meet any of the requirements of the Specifications, written notice of the rejection shall be given to the Contractor and work shall be halted until corrective action is taken.

**3.05.4** Periodic construction observation is only an aid to the Contractor and in no way reflects any responsibility on the part of the City for quality or quantity control, and in no way implies acceptance of the work, or any part thereof, by the City.

**3.05.5** Water Engineering Inspections personnel will only inspect wet utility piping, appurtenances and backfill. All other inspections (grading, paving, etc.) are required to be inspected by the Public Improvement Inspections Division of Public Works.

### **3.06 Initial Acceptance for Utilities**

When the final clean up has been performed, the Contractor shall notify the Water Engineering Inspector all work has been completed and schedule an inspection. The Water Engineering Inspector will perform all necessary inspections and notify the contractor of any defects. At the time of Initial Acceptance the City will accept the facility for operation only.

The "NOTICE OF INITIAL ACCEPTANCE," which begins the warranty period will be issued when the following items are completed:

- The Water Engineering Inspector has accepted the physical aspects of the construction.
- A "Release and Indemnification" statement has been delivered to Water Engineering.
- All testing requirements have been satisfied.

Water lines must undergo chlorine, pressure and bacteria testing prior to issuance of the initial acceptance. Sanitary sewers require visual acceptance by Water Engineering Inspections and the contractor is also required to submit a Closed Circuit Television inspection of the line to be reviewed by Aurora Water (See Section 21.07) for Initial Acceptance. Storm sewers require visual inspection only by Water Engineering Inspections. The Water Engineering Inspector will perform all necessary inspections and notify the Contractor of any noted defects in writing. When all defects are corrected, the work will be accepted for initial acceptance and the warranty period shall begin.

No water service taps are allowed on a newly constructed water main until a Notice of Initial Acceptance has been issued from the Inspector.

Sanitary sewer service permits shall not be issued until the Notice of Initial Acceptance has been issued from the Water Engineering Inspector for the sanitary sewer main.

### **3.07 Warranty Period**

The warranty period for all work is for 1 year from the date of initial acceptance or substantial completion, unless otherwise specified in this manual or mutually agreed upon in writing.

### **3.08 Final Acceptance for Utilities**

The City may at its discretion re-inspect any project at any time during the warranty period. Any defects noted prior to the warranty expiration shall be corrected by the Owner/Developer/Contractor at their expense. Final acceptance will be issued in writing when defects are corrected, and all repairs to existing facilities, improvements, and vegetation are completed per applicable requirements. When final acceptance has been issued, the infrastructure will become the responsibility of the City of Aurora. Any failures or defects that occur within the warranty period are the responsibility of the owner regardless of timing of inspection(s). Water lines are re-inspected near the end of the warranty period to ensure valves are operable, valve boxes and fire hydrants are to grade, etc. Sanitary sewer and storm drain infrastructure are re-inspected prior to the final acceptance for surface defects. Discrepancy (punch) lists for these items will be mailed to the owner/contractor and must be corrected prior to final acceptance.

## **SECTION 4.00 JOB SITE SAFETY, HEALTH AND ENVIRONMENTAL REQUIREMENTS**

- 4.01 OCCUPATIONAL SAFETY AND HEALTH ADMINISTRATION
- 4.02 PROTECTION OF WORK AND PROPERTY
- 4.03 ACCIDENT PREVENTION
- 4.04 SANITARY REGULATIONS
- 4.05 PREVENTION OF WATER POLLUTION
- 4.06 DEWATERING
- 4.06 ABATEMENT OF AIR POLLUTION
- 4.07 DUST ABATEMENT

## **SECTION 4.00 JOB SITE SAFETY, HEALTH AND ENVIRONMENTAL REQUIREMENTS**

### **4.01 Occupational Safety and Health Administration**

The Contractor must conform to the rules and regulations of the Occupational Safety and Health Administration. In addition, the Contractor shall conform to all applicable rules and regulations adopted by the City of Aurora. In case of conflict between two or more rules and regulations, the more restrictive shall apply.

### **4.02 Protection of Work and Property**

The Contractor shall continuously maintain adequate protection of all his work from damages and shall protect the City's property from injury or loss arising in connection with his construction. He shall make good any such damage, injury or loss resulting from such construction. He shall adequately protect adjacent property as herein provided. He shall provide and maintain all passage ways, guard fences, lights and other facilities for protection required by public authority or local conditions.

The Contractor shall be responsible for protection of all public and private property adjacent to the site of the work including but not limited to pipes, conduits, and other underground structures; overhead wires; and to roadways, alleys, trees, landscaping, bikeways and sidewalks. He shall carefully protect from disturbance or damage all land monuments, until a Registered Land Surveyor has witnessed or otherwise referenced their location, and shall not remove them until directed. The Contractor is subject to state statutes regarding destruction of monuments. When any direct or indirect damage or injury occurs to public or private property by or because of any act, omission, neglect, or misconduct in the execution of the work, or in consequence of the non-execution thereof on his or her part, then such damaged property shall be restored by the Contractor at his or her own expense to a condition equal to or better than the existing before such damage or injury.

### **4.03 Accident Prevention**

The Contractor shall always, whether or not so specifically directed by the Inspector, take necessary precautions to ensure the protection of the public. The Contractor shall furnish, build, and maintain, at his own expense, all necessary barricades, suitable and sufficient warning lights, construction fencing and construction signs. Contractor shall provide a sufficient number of watchmen and take all necessary precautions for the protection of the work and safety of the



public through or around his construction operations.

#### **4.04 Sanitary Regulations**

The Contractor shall be responsible for providing proper health and sanitation facilities for his employees. Rules and regulations of the Colorado Department of Public Health and Environment, or other bodies having jurisdiction, shall be fully complied with. The Contractor shall always provide an abundant supply of safe drinking water for his employees and shall give orders against the use of water in the vicinity of the work known to be unsafe. The Contractor shall provide outside toilets maintained in sanitary condition at convenient locations. Privy toilets which require a hole in the ground shall not be allowed.

#### **4.05 Prevention of Water Pollution**

The Contractor shall comply with City of Aurora Rules and Regulations Regarding Stormwater Discharges Associated with Construction Activities.

#### **4.06 Dewatering**

Dewatering is subject to permitting by the State and shall be conducted according to an approved City of Aurora dewatering plan through Environmental Inspections Division of Aurora Water.

#### **4.07 Abatement of Air Pollution**

The Contractor shall comply with all applicable Federal, State, County and City laws and regulations concerning the prevention and control of air pollution. In conduct of construction activities and operation of equipment, the Contractor shall use such practicable methods and devices as are available to control, prevent, and otherwise reduce atmospheric emissions or discharges of air contaminants.

The emission of dust into the atmosphere shall not be permitted during the manufacture, handling and storage of concrete aggregates. The contractor shall use such methods and equipment as are necessary for the collection and disposal or prevention, of dust during these operations. The Contractor's methods of storing and handling cement and ad-mixtures shall also include means of eliminating atmospheric discharges of dust.

Equipment and vehicles showing excessive emissions of exhaust gases due to poor engine adjustments, or other inefficient operating conditions, shall not be operated until corrective repairs or adjustments are made.

Burning of materials including trees and brush, combustible construction materials and rubbish IS NOT permitted by the City of Aurora. All such materials shall be removed from the site and legally disposed of at the Contractor's expense.

#### **4.08 Dust Abatement**

During the performance of the work required by these Specifications or any operations appurtenant thereto, whether on right-of-way provided by the City or elsewhere, the Contractor shall be required to furnish and apply a dust palliative on portions of the project and on haul roads at the locations and in the amounts as may be called for on the plans or as directed. Dust palliate may consist of water or a dilution of water and emulsified asphalt, or other approved substance. Dust palliative shall be of the type and proportions called for on the plans, or as directed. Spreading of water or water mixture shall be done with acceptable sprinkling equipment.

The Contractor shall be held liable for any damage resulting from dust originating from his operations under these Specifications on right-of-way or elsewhere.

## **SECTION 5.00 UTILITY DESIGN CRITERIA AND CONSTRUCTION PLANS**

- 5.01 GENERAL
- 5.02 WATER DISTRIBUTION LINES DESIGN CRITERIA
- 5.03 SANITARY SEWER SYSTEM DESIGN CRITERIA
- 5.04 ALIGNMENT, DEPTH AND EASEMENTS
- 5.05 CIVIL CONSTRUCTION PLAN REQUIREMENTS
- 5.06 MANHOLE SPACING
- 5.07 BARREL SIZE
- 5.08 IRRIGATION PLANS

## SECTION 5.00 UTILITY DESIGN CRITERIA AND CONSTRUCTION PLANS

### 5.01 General

Civil Plans and Reports shall be submitted in accordance with requirements outlined in the Roadway Design and Construction Specifications Chapter 2. Construction plan guidelines and drafting standards are outlined in the Roadway Design and Construction Specifications Chapters 2 and 3.

All plans shall be checked for conformance with the minimum design criteria set forth in these Specifications prior to approval for construction. Variances from these criteria shall be reviewed and approved on a case-by-case basis with the civil plan submittal. To request a variance from these Specifications, include the following table on the Utility Plan:

Variance Requests			
Section #	Description	Reason Specification Cannot Be Met	AW Approval

### 5.02 Water Distribution Lines Design Criteria

All additions to the City of Aurora water distribution system shall be designed in accordance with the criteria set forth in this and other sections of these Specifications as approved by the City Engineer and the Water Department. Ductile Iron Pipe (DIP) or Polyvinyl Chloride pipe (PVC) shall be used exclusively, unless special approval is obtained in writing by Aurora Water Engineering.

**5.02.1 Master Water Plan and Report** A master water plan (minimum scale 1"=100') shall be submitted for each major development with the Framework Development Plan (FDP) or Contextual Site Plan (CSP) prior to approval of any portion of the water system as required by Aurora Water Engineering. Master water plans shall otherwise conform to the drafting guidelines outlined in the Roadway Design and Construction Specifications Chapters 2 and 3. A Master Water Report shall have a narrative identifying the scope, intent, criteria, water system requirements, and phasing of improvements. Furthermore, the report must analyze the

proposed distribution system for Average Day, Maximum Hour and Maximum Day plus Fire Flow per current NFPA codes. Water master plans shall be evaluated relative to the City-wide master plan, and all phases of construction must meet minimum criteria established by the City's master plan to ensure regional water transmission goals.

**5.02.2 Main Size** The water distribution shall be designed to meet the maximum hour to average day ratio of 4.5:1 gallons per person per day (maximum day to average day ratio of 2.8:1, for an average daily usage of 160 gallons per day per person). The system shall be analyzed to meet the maximum day plus fire flow demand (as determined by ISO criteria) with a residual pressure of no less than 20 psi at any point in the water distribution system. The velocity of the water in the system shall not exceed 5 feet per second during maximum day plus fire flow or maximum hour demands for mains 16 inches or larger. Maximum velocity shall be 10 feet per second for 12 inch mains and shall be 15 feet per second for 8 inch or smaller mains. Design parameters and the critical conditions shall be shown on an overall plan of the study area. A complete analysis shall be submitted for any fire demand 1,500 gpm or greater. In addition the following minimum conditions shall be met:

The minimum diameter for water mains in single family detached residential areas shall be 8 inches, unless 6 inch pipe is required in a particular location by the Aurora Water Engineering due to potential water quality issues. A maximum of 12 residential units are allowed to be served from a dead end water main. Water mains servicing schools, commercial, industrial, retail developments, and multi-family attached residential areas shall be a minimum of 8 inches in diameter. Aurora Water Engineering may require larger mains based upon regional needs. Twelve inch diameter feeder lines shall be spaced between transmission lines with a maximum distance of 3,000 feet apart and looped to provide water from more than one source. 4 inch, 10 inch and 14 inch mains are not allowed.

### 5.02.3 Domestic Water Demand per Zoning Classification

#### RESIDENTIAL – based on 160 gallons per capita per day

Zoning	Average Day (gpm/acre)	Max Day (gpm/acre)	Max Hour (gpm/acre)	People per Unit	Units per Acre
R-A, R-E R-O, R-1	2.58	7.22	11.60	3.2	7.25
R-2, R-2M P-MH	4.67	13.07	21.00	2.1	20
R-3, R-3MH, MH R-4, R-4H, R-5	7.56	21.16	95.2	1.7	40

#### COMMERCIAL

Zoning	Average Day (gpm/acre-building)	Max Day (gpm/acre-building)	Max Hour (gpm/acre-building)
B-1, B-2, B-3 , B-4	4.52	14.46	18.80
A-O B-O	1.80	6.34	8.24
M-O, M-1, M-2, M-3	1.00 *	5.12	6.65

\*Average day usage in M Zonings is based upon a standard warehousing operation. Other uses in this zoning require special calculations.

### 5.02.4 Fire Hydrants

Dead-end water lines supplying fire hydrants must maintain a minimum available residual pressure of 20 psi for firefighting purposes. No more than one fire device (fire hydrant or fire suppression line) is allowed off of a dead-end water line extension. The water line supplying the dead-end line must be supplied from a looped system. Any dead-end water line supplying a fire hydrant that exceeds 150 ft. require calculations to be shown on the utility sheet of the civil drawings. The calculation provided must reflect no less than a 20-psi residual water pressure.

## 5.03 Sanitary Sewer System Design Criteria

The following shows the recommended sewer loading rates for a variety of types of developments. These rates for the design of sanitary sewers shall be used as a general guide for designers in addition to the ASCE Manuals and Reports on Engineering Practice No. 60, Gravity

Sanitary Sewer Design and Construction (Manual). Where possible, counts of actual number of units shall be made for all residential zoning per tables on page 2-5 otherwise, the zoning category with the loading factor per table on page 2-5 shall be used. All loading factors are for average flows. The peak flow shall be based on Curve "A" of the Manual for the ratio of peak to average daily sewage flow as determined and shown on Figure 3-1 of the Manual:

The equation for Curve "A" is:  
$$5 \div p^{0.167}$$
 where p = population in thousands

A maximum peaking factor of 4 and a minimum of 1.7 shall be used for this equation.

The master utility study should include the estimated peak quantity of wastewater tributary to the study area and included with the report. A Framework Development Plan which is a part of the master plan for the City of Aurora shall be the basis for determining the character of developed land outside the study area. The proposed outfall points for wastewater, demand per each type of unit, number of units, peaking factor, infiltration at 10% of average flow, and maximum daily demand from the study area should also be included in the master utility report. All sanitary sewer systems shall be designed in accordance with the criteria established by the Colorado Department of Public Health and Environment with the following exceptions:

**5.03.1** There shall be no horizontal or vertical curves on sanitary sewers.

**5.03.2** All sanitary sewer mains shall end with a manhole except where a short (4 feet maximum) stub-out section from the last manhole may be allowed for future main extensions or private service connections.

**5.03.3** The flow velocity shall not exceed ten (10) feet per second flowing full or 1/2 full using Manning's formula and (N=0.011 for PVC) or (N=0.013 for RCP or VCP). Minimum Slope = 0.4%, with a minimum velocity of two (2) feet per second at least once per day.

**5.03.4** Minimum drop through a manhole from inlet to outlet for same diameter pipe shall be:

- 0.2 ft. on straight through runs
- 0.3 ft. on deflected bends greater than 45 degrees; pipe laid through a manhole shall be at a slope of the same grade as the downstream pipe slope
- For pipes of differing diameters, match HGL's or crowns of pipes.

**5.03.5** A maximum inside drop of 18 inches from inlet to outlet for same diameter pipe is allowed, but only if the inlet pipe must avoid upstream conflicts.

**5.03.6** Depth of flow in pipes should not exceed 75% of capacity for pipes 12 inches or smaller and 90% for pipes larger than 12 inches.

**5.03.7** Minimum slope of 2% on four inch service lines. Other size service lines require a minimum 2 feet per second velocity once per day.

**5.03.8** Direct service line taps shall not be allowed on sewer mains 24 inches in diameter and larger.

**5.03.9 Recommended Sewer Loading Rates for Different Types of Developments**  
**RESIDENTIAL**

Zoning	People per Unit	Average Day Per Capita Flow (gpd)	Dwelling Units per Acre	Average Flow (gpd/acre)
R-A, R-E R-O, R-1	3.2	80	7.25	1856
R-2, R-2M P-MH	2.1	80	20	3360
R-3, R-3MH, MH R-4, R-4H, R-5	1.7	80	40	5440

**COMMERCIAL**

Zoning	Average Day Flow (gpd/acre)	Equivalent Population
B-1, B-2, B-3, B-4	4000	50
A-O B-O	2000	25
M-O, M-1, M-2, M-3 *	1200	15

\* High water usage industries in M Zonings require special calculations based



on actual projected sanitary sewer loadings for the industry.

### **SCHOOLS**

10 GPD/student (Elementary school without showers)

35 GPD/student (Middle & High schools with showers)

Add 10% Inflow and Infiltration for all Zonings. (Do not peak I & I)

## **5.04 Alignment, Depth and Easements**

Water mains shall be placed ten (10) feet north and east of street centerlines. For parkways or a major arterial with twenty (20) foot wide islands, water mains shall be placed twenty (20) feet north and east of street centerlines. Water mains shall be a minimum of five (5) feet from the edge of the concrete gutters at all locations, except as approved by the Water Department. A minimum cover of four and one-half (4 1/2) feet below final grade shall be maintained over all water mains and service laterals. Curvilinear PVC water mains are not allowed. When water pipes cross sanitary sewer lines, the water line must be laid above the sanitary sewer line with a twenty four (24) inch minimum vertical separation (includes water and sanitary services) with all pipe joints no closer than ten (10) feet horizontal from the sanitary sewer pipe centerline. In the case where a twenty-four (24) inch separation cannot be kept or sewer lines cannot be located below the water line, special design to protect water quality required. This may include concrete or steel encasement at the direction of the Water Department. For more information on specific crossing parameters, see Section 11.08 of these Specifications. Water mains, sanitary sewers, and storm sewers are required to extend the complete length of the property frontage or completely through the property being served if there is any possibility of a future extension of the main.

In no instance shall manholes or valves encroach on curb and gutter sections, crosspans, etc. Meter pits and curb stop valves are not allowed in, or under, driveways, sidewalks or curb and gutter.

Meters and Hydrants Required Easements

Fixture	Easement
¾" to 1" meter	10' wide and 5' behind meter pit <u>or</u> in R.O.W. behind back of walk or in the tree lawn if detached walk is required
1 ½ " to 2" meter	10' wide and 5' behind meter pit
3", 4", 6"	18' wide and 5' behind meter pit
Fire Hydrant	10' wide and 5' behind hydrant

Utility Mains Required Easements\*

Average Depth of Main	Easement
0'-6'	16' wide
6'-10'	20' wide

Mains greater than 10 feet in depth require easement dedication width to provide a 1:1 slope from the edge of the easement to the bottom of the pipe. Easements covering more than one wet utility require a width sufficient to provide a 1:1 slope from the edge of the easement to the bottom of the outside pipe.

In no case shall any trees, walls, large rocks, fences, etc., be within a utility easement or within 8 feet of a public utility line unless prior approval has been obtained from the Water Department and a revocable license or license agreement has been obtained. It is the responsibility of the designing firm to coordinate with the landscape architect during preliminary site development to avoid locating such landscaping features within a utility easement.

**5.05 Civil Construction Plan Requirements**

Civil construction plans for water, sanitary sewer and storm sewer infrastructure shall conform to the requirements set forth in Public Works Roadway Design and Construction Specification; Section 2.06. Additionally, the following requirements shall be met for plan approval as applicable:

**5.05.1 Standard Notes** The following notes must appear on all overall water plans:

- 1) All materials, workmanship, construction details, and testing for the water line construction shall conform to Standards and Specifications Regarding Water, Sanitary Sewer and Storm Drainage Infrastructure, latest revision as set forth by the City of Aurora Water Department, latest revision.
- 2) All fire hydrants shall be located not less than three feet - six inches (3' – 6") and not more than 8 feet from the back of curb to the center of the hydrant and be unobstructed on the street side. Minimum clearance on all other sides shall be 5 feet. Fire hydrants must be grade staked in the field. Fire hydrants are not allowed in sidewalks.
- 3) All fire hydrants must be grade staked in the field whenever curb and gutter has not been installed.
- 4) All utility easements must remain unobstructed and fully accessible along their entire length for maintenance equipment.
- 5) Water main restraint shall be in accordance with Standards and Specifications Regarding Water, Sanitary Sewer and Storm Drainage Infrastructure, latest revision. Megalugs or Uni-flange may be used in place of rods and clamps.
- 6) Water line valves are not allowed in cross pans.
- 7) All water meters, water service lines and sanitary sewer service lines are not allowed in or under driveways.
- 8) All sanitary service lines shall be tees off of mains. Wyes shall be used for lots at back of cul-de-sacs.
- 9) Water Pressure Zone \_\_\_\_\_(insert water pressure zone where development is located). Zero (0) psi @ elevation \_\_\_\_\_(insert static elevation for specific zone) static. A pressure reducing valve (PRV) is required when the pressure at the unit is greater than (80) psi. PRV's are not allowed in City of Aurora owned and maintained meter pits.
- 10) Adjust all manholes, fire hydrants, and valve boxes to grade per Aurora Water

Standards and Specifications Regarding Water, Sanitary Sewer and Storm Sewer Infrastructure, latest revision, as necessary.

- 11) All fire lines and commercial water service lines require reduced pressure back flow assembly or double check valves as required by the City of Aurora Water Department. Contact Water Services at (303) 326-8114 or (303) 326-8129 for inspection prior to the issuance of a certificate of occupancy.
- 12) The contractor shall contact Aurora Water Engineering at (303) 739-7300 for inspection of any required grease traps or sand/oil interceptors prior to the issuance of the certificate of occupancy.
- 13) The contractor shall contact the Aurora Water Inspection Line at (303) 739-7385 at least 24 hours in advance of commencing construction of any wet utility to schedule inspections.
- 14) Total Building Surface Area = \_\_\_\_\_ S.F. Total Hard Surface = \_\_\_\_\_ S.F.

**5.05.2 Resistivity Tests** Resistivity tests are required for all sites according to Section 20.01 of these Specifications. Specifying PVC pipe on the civil plan submittal does not eliminate the need for resistivity testing.

If resistivities are less than or equal to 1000 ohm-centimeters, PVC water main for line 12 inches and under in diameter, including fire hydrant laterals, is required for the site. DIP and steel for larger diameter mains may be used in these soil conditions with appropriate cathodic design (see Section 20)

For sites using PVC mains under the above conditions, the following notes are required to be added to standard utility notes:

- 1) Ductile iron and steel pipe shall not be used on this site due to the corrosive nature of the soils. All pipe shall be PVC per Section 14 of the Standards and Specifications Regarding Water, Sanitary Sewer and Storm Drainage Infrastructure, latest revision.
- 2) All ductile iron fittings and appurtenances shall be double bonded and double poly-wrapped per Section 12 of the Standards and Specifications Regarding Water, Sanitary Sewer

and Storm Drainage Infrastructure, latest revision.

3) Resistivity testing is required with first submittal of civil drawings. The submittal may be rejected if the tests are not included.

**5.05.3 Water Services** Fixture unit table and meter sizing table (see sample on page 2-13) are required for all commercial and multi-family water services. Meters shall be sized per the 1991 Uniform Plumbing Code, or alternatively, to the current International Plumbing Code as adopted by the City Building Division.

All water service connections and meters shall be uniform size from the service line tap to the building structure or structures. The Water Department shall reserve the right to require a larger service connection to any building, structure, or development if the water requirements when calculated by the fixture unit method, as specified in the Uniform Plumbing Code or the International Plumbing Code, cause the service line velocity to exceed (10) feet per second. Each service line and meter shall supply a specific building. The banking of meters where a particular building or group of buildings may be supplied by 2 or more meters shall be prohibited, except in unusual circumstances where two 2 meters may be allowed by the Director of Aurora Water or his authorized representative. If the applicant for a water service connection desires to stub-out service line connections for water and sanitary sewer into the property for the purpose of paving, one hundred (\$100.00) dollars per stub-out shall be due and payable at the time the permit for stub-out is requested. The balance of the service connection fees shall be due at the time the water meter is requested. Service connection fees are payable after issuance of building permit and 24 hours prior to request for meter set. The fee shall be calculated on the basis of service connection fees in effect as of the date of full payment. Water and sewer service stub-outs not utilized at the time of development require disconnection at the main. Disconnection of existing unused water and sanitary sewer service lines shall be the developer's responsibility. Water services may not be tapped from mains larger than 12 inches in diameter.

A fullway valve controlling all outlets shall be installed on the discharge side of each water meter. Water piping supplying more than one building on any one premises shall be equipped with a separate fullway valve to each building, provided, however, the supply piping to a single family residence and building accessory thereto may be controlled on one valve. Such shut-off valves shall be readily accessible at all times. A fullway valve shall be installed for each

apartment or dwelling for more than one (1) family.

**5.05.4 Fire Suppression Lines** Proposed fire suppression lines to each building shall be shown and labeled “Private”. Individual fire service lines are required for each sprinkled building and must be tapped from a looped water main. All fire service lines shall be Ductile Iron for lines 3" and larger or type 'K' copper for lines 2" and smaller from the main line to the backflow assembly in the building, except as explicitly approved by the Water Department. 2 inch and smaller fire service lines shall have a tee and 4 inch gate valve with a 2 inch or smaller threaded plug, copper service threaded union, and service insulator per Detail #223. 3 inch fire lines shall have a tee, 4 inch gate valve, and 4 inch by 3 inch reducer per Detail #223. In no case shall a gate valve less than 4 inches in diameter or a gate valve more than 10 inches in diameter be installed on a fire service line at the main.

When a fire sprinkler system or standpipe system is being installed within any structure the following notes are required:

- 1) All fire service lines shall be installed, in their entirety, by a state licensed contractor. Licensing can be obtained from the Colorado Division of Fire Safety located at 690 Kipling Street, Suite 2060, Lakewood, CO. 80215 (303-239-4600). In addition, approved civil plans from the City of Aurora Water Department are required for all fire service line connections. The Contractor must present license and approved civil plans to the Permit Center before permits are issued.
- 2) Upon permit issuance contact the City of Aurora Building Codes Division at (303) 739-7420 to schedule a flush inspection with a Life Safety Inspector.
- 3) Fire service lines shall be restrained for their entire length. Refer to Standards and Specifications Regarding Water, Sanitary Sewer and Storm Drainage Infrastructure, Section 18 of these Specifications.
- 4) Other than the 90 degree vertical bend in the fire service line at the building riser, fire service lines may have one 90 degree bend, or more than one bend when the sum of all bends does not exceed 90 degrees, in the length of line from the water main tee to the riser.
- 5) No connections are allowed to the fire service line between the gate valve at the water line main and the backflow preventer (within the building).

## 5.06 Manhole Spacing

The maximum distance between manholes shall be as follows:

### SANITARY

<u>Pipe Size</u>	<u>Maximum Distance</u>
8" to 15"	400'
18" to 30"	500'
larger than 30"	600'

### STORM

<u>Pipe Size</u>	<u>Maximum Distance</u>
18" to 36"	400'
42" to 60"	500'
larger than 60"	750'

Manholes are required for all junctions in the Storm Sewer System unless specifically authorized by Aurora Water Engineering. Maintenance access is required to within five feet of all manholes. Maintenance access for sanitary sewer manholes is required to be designed for HS-20 loading.

## 5.07 Manhole Barrel Size

The alignment of pipes into the manhole shall determine the barrel size for the size of pipe used. The internal diameter of the manhole barrel shall be as follows:

### SANITARY

<u>Pipe Size</u>	<u>Barrel Size</u>
12" or less	48"
15" to 27"	60"
30" to 48"	72"

### STORM

<u>Pipe Size</u>	<u>Barrel Size</u>
27" or less	60"
30" to 48"	72"

Manholes with pipes larger than 48 inch, or when a separation of one foot inside the manhole between outside diameters of incoming/outflowing pipes cannot be met require special vault designs. CDOT M-Standards may be used for larger vaults. Landing platforms shall be provided only when specifically requested by the Water Department.

## **5.08 Irrigation Plans**

Irrigation plans are required to be submitted and approved by Aurora Water for all new multi-family, commercial and common space development as a separate submittal from the Civil Plan submittal. Irrigation systems must be inspected prior to Certificate of Occupancy. See Appendix D: Irrigation System Standards and Details for more information.





**THIS PAGE IS INTENTIONALLY BLANK**

## **SECTION 6.00 PROTECTION OF EXISTING FACILITIES**

- 6.01 GENERAL
- 6.02 CONCRETE WORK
- 6.03 PAVEMENT REPLACEMENT
- 6.04 UNDERGROUND UTILITIES

## **SECTION 6.00 PROTECTION OF EXISTING FACILITIES**

### **6.01 General**

The Contractor shall notify all utility companies (Electric, Gas, Telephone, Cable T.V., etc.) and all other necessary parties before commencement of work. Existing power lines, telephone lines, trees, shrubbery, fences, water mains, irrigation systems, gas mains, sewer mains, sewers, cables, conduits, ditches, embankments, and other structures in the vicinity of the work not authorized to be removed shall be supported and protected from injury by the Contractor during the construction and until completion of the work affecting them. The Contractor shall be liable for all damages to such existing facilities and structures, as herein provided, and he shall save the City harmless from any liability or expense for injuries, damages, or repairs to such facilities.

All paving, curbing, sidewalks, gutters, turf, native grasses, trees, shrubbery, fences, irrigation ditches, pipes or other structures or surfaces damaged during construction shall be replaced to an equal or better condition at the Contractor's expense. This work shall be done when conditions warrant and shall be completed to the satisfaction of the Engineer. Upon completion of construction, surplus materials, equipment, tools and temporary structures shall be removed by the Contractor. All dirt, rubbish and excess earth from excavations shall be disposed of by the Contractor and the construction site shall be left clean and orderly. Construction done on private property shall be restored to a condition at least equal to or better than before work began and to the satisfaction of the Engineer. Contractor and/or owner are required to satisfy requirements of the City's Tree Mitigation Policy.

The Contractor shall not use private property outside construction easements without first obtaining written permission from the property owner. This permission shall be worded so as to hold the City, its employees and agents harmless.

### **6.02 Concrete Work**

All concrete used in restoration work including all curb, gutter, sidewalk and concrete street replacement work shall conform to the requirements set forth in the City of Aurora, Roadway Design and Construction Specifications, Section 30 or to the requirements of the Street or Highway Department having jurisdiction. All concrete used in City of Aurora Parks, Recreation and Open Space properties shall conform to the Parks, Recreation and Open Space Development Manual.

### **6.03 Pavement Replacement**

Unless authorized by the Engineer, all pavement shall be replaced per Section 36 of City of Aurora Public Works Roadway Design and Construction Specifications. Permanent or temporary surfacing shall be installed and maintained as required by the Engineer. All pavement used in City of Aurora Parks, Recreation and Open Space properties shall conform to the Parks, Recreation and Open Space Development Manual. If the Contractor fails to give timely response to the Engineer's request for installation or maintenance of the surfacing, the Engineer will arrange for the required work to be done at the Contractor's expense. If it becomes necessary for the Engineer to instigate such an action, a hold may be placed on all future permits until the problem is rectified.

### **6.04 Underground Utilities**

The type, size, location, and number of all known underground utilities are approximate when shown on the drawings. It shall be the responsibility of the Contractor to verify the existence and location of all underground utilities within the work area. The Contractor shall be responsible for unknown underground utilities.

The Contractor shall notify the appropriate City Department or owner of the existing utilities, whether above ground or underground, before proceeding with trench excavation whenever such trenching operations are within ten feet of any existing utilities. Should any such utility be damaged in the trenching operations, the Contractor shall immediately notify the owner of such utility. Unless authorized in writing by the owner of the utility, the Contractor shall not attempt to make repairs. Duplicate copies of any written authorization given to the Contractor to make repairs shall be filed with the Engineer and shall be so worded as to hold the City harmless of any responsibility whatsoever concerning the sufficiency of the repairs.

If during construction, it is determined that any underground utility conduit including, but not limited, to sewers, water mains, gas mains, drainage structures, and any above ground utility facilities are required to be moved, the Contractor shall notify the utility owner before his approach to such utility so that arrangements with the City or owners of the affected utility can be completed without delay to the work.

**THIS PAGE IS INTENTIONALLY BLANK**

## **SECTION 7.00 MATERIAL HANDLING AND STORAGE**

- 7.01 GENERAL
- 7.02 MATERIALS HANDLING
- 7.03 MATERIALS STORAGE

## **SECTION 7.00 MATERIAL HANDLING AND STORAGE**

### **7.01 General**

Unless otherwise specified, all pipe handling and storage shall be based upon manufacturers' recommended practice for installation of each specified type of pipe. Provisions of these Specifications shall supercede and augment those recommendations.

### **7.02 Material Handling**

All materials shall be delivered to the construction site free of contamination. Contamination shall include, but not be limited to, dust, dirt, mud, petroleum products, trench water, paint, pesticides, stones, animals, and insects.

Pipe, fittings, and accessories shall be loaded and unloaded by lifting with hoists or skidding to avoid shock or damage. Under no circumstances shall such materials be dropped. Pipe handled on skidways shall not be skidded or rolled against pipe already on the ground. If any part of the coating or lining is damaged, the Contractor shall repair or replace the material affected at his expense as required by the Engineer or Inspector.

Precautions shall be taken to prevent contamination of the materials. The Inspector shall stop all work when he deems the work to be unsafe, inconvenient or when proper contamination control is not exercised.

### **7.03 Material Storage**

Pipe shall not be stacked higher than allowed by the manufacturer. Stringing of pipe is allowed but shall be free of debris before placement of the pipe. Stored pipe shall be protected from adverse weather, harmful chemicals, dirt or debris accumulating on the interior of the pipe. The Contractor before placement shall remove any deleterious material from the interior of the pipe. PVC and HDPE pipe shall be protected from long term exposure to sunlight.



## **SECTION 8.00 EXCAVATION**

- 8.01 GENERAL
- 8.02 TRENCH EXCAVATION
- 8.03 TRENCH SIDE WALLS
- 8.04 SHORING
- 8.05 ROCK EXCAVATION
- 8.06 BLASTING
- 8.07 PAVEMENT REMOVAL
- 8.08 PREPARATION FOR PIPE LAYING

## **SECTION 8.00 EXCAVATION**

### **8.01 General**

Except where shown otherwise on approved drawings, and unless the Engineer gives written permission to do otherwise, all trench excavation shall be made by open cut to the depth required to construct the pipeline as shown on the drawings. The length of a trench permitted to be open at any one time is limited per City of Aurora Rules and Regulations Regarding Stormwater Discharges Associated with Construction Activities.

All earthworks and structural excavation and backfill shall conform to Sections 20 and 21 of City of Aurora Roadway Design and Construction Specifications.

### **8.02 Trench Excavation**

The width of trenches shall be only the width necessary for the proper placement of the pipe. There shall be a minimum of eight (8) inches between the trench wall and the wall of the pipe or eighteen (18) inches if a trench box is used. All unauthorized excavation below the established depth made without the written authorization of the Engineer shall be refilled with compacted granular bedding material per Section 9.00. Trenches in existing streets are subject to the provisions of Section 36: City of Aurora Roadway Design and Construction Specifications.

### **8.03 Trench Side Walls**

When the trench side walls are sloping or benched, the sloping or benching shall end at a depth not less than one foot and no greater than four feet above the top of the pipe barrel. From this point down the trench wall shall be vertical. The trenching operation, including the spoil band, shall be confined to the width of the combined permanent and temporary rights-of-way. Under no circumstances shall the Contractor use any areas outside the right-of-way without first receiving written permission, holding the City harmless, from the property owner.

A clear area shall be maintained a sufficient distance back from the top edge of the excavation to avoid overloading which may cause slides or caving of the trench walls. The excavated material shall be kept trimmed enough to be of as little inconvenience as possible to the public and adjoining property owners. Unless otherwise authorized by the Engineer, all public thoroughfares and crossroads shall be kept open to safe two-way traffic. At street crossings, sidewalks and other points where the Engineer deems necessary, the trenches shall be bridged safely to prevent serious interruptions of travel and to provide access to fire hydrants and public and private premises. Such bridging shall be approved by the Engineer.

## **8.04 Shoring**

All trench side walls which require shoring shall be properly sheeted and braced to furnish safe working conditions. The shoring shall be arranged so as not to place any stress on portions of the completed work until the general construction of the work has proceeded far enough to provide ample strength. Any damage to pipes or structures occurring through settlements, heaving, water or earth pressures, slides, caving or other causes, due to failure of shoring, or due to improper shoring, or due to negligence by the Contractor, shall be repaired by the Contractor at his own expense. Sheet piling may be used for shoring. Shoring shall be removed as work progresses, unless left in place, by written order of the Engineer.

If at any point the Engineer determines the trench walls to be not properly supported, he may order the placement of additional supports by and at the expense of the Contractor. Compliance with such an order shall not relieve or release the Contractor from his responsibility for the safety of the work.

The Contractor is responsible for ensuring his/her work complies with all necessary OSHA guidelines.

## **8.05 Rock Excavation**

Rock excavation shall consist of igneous, metamorphic and sedimentary rock which cannot be excavated without blasting or the use of rippers, and all boulders or other detached stones each having a volume of two (2) cubic yards or more. Where rock, hardpan or other unyielding material is encountered, it shall be removed below the designed grade for a depth of six (6) inches. This extra depth excavation shall be backfilled with compacted granular bedding material per Section 9.00.

## **8.06 Blasting**

Excavation blasting shall be permitted for portions of the work which may be expedited if a written permit is given by the Engineer, and a permit is granted by the City of Aurora Fire Department. These permits shall be kept on site for inspection. The Engineer shall have the right to limit the use of explosives or to order the discontinuance of any blasting methods which in his opinion endanger the safety of inhabitants of the area, the traveling public or any part of any public or private property.

The Contractor shall enlist the services of a Professional Explosives Engineer. All blasting shall be according to the Explosive Statutes of Colorado.

Blasting shall be performed in a manner that no damage will result to any building, structure, pipeline, or facility on or off the site of the work, or above or below ground line. Any damage suffered because of blasting shall be repaired to the satisfaction of the Engineer, at the Contractors expense. Blasting shall be done so the rock is not loosened nor disturbed below the pipe foundation. Blasting in a trench shall not proceed until the trench walls have been shored or braced satisfactorily to the Engineer.

### **8.07 Pavement Removal**

Excavation in paved streets shall meet the minimum trench width requirements. Excavations within paved City Streets are subject to the provisions in Section 36: City of Aurora Roadway Design and Construction Specifications.

THERE SHALL BE NO DUMPING OF UNAUTHORIZED MATERIAL INSIDE THE CITY LIMITS OF THE CITY OF AURORA.

### **8.08 Preparation for Pipe Laying**

When the excavation is in firm earth, care shall be taken to avoid excavation below the established grade plus the required specified over-excavation to accommodate the granular bedding. Over excavation shall be replaced using stabilization materials and compacted to City Specifications unless otherwise specified in writing by the Engineer.

#### **8.08.1 Unstable Trench Conditions**

When soft or otherwise unstable foundation materials are encountered in the bottom of the trench these materials shall be removed and replaced with stabilization materials or a concrete cradle. Materials which are wet do not solely constitute unstable foundation material.

#### **8.08.2 Stabilization Material**

Stabilization material shall be uniformly graded washed rock conforming to the following sieve analysis. A layer of 8 mil polyethylene or Mirafi 140 and a minimum of six (6) inches of granular bedding material shall be placed over the stabilization material as required per Standard Detail 100.

<u>SIEVE SIZE</u>	<u>PERCENT PASSING</u>
2"	95 - 100
1"	35 - 70
1/2"	10 - 30
#4	0 - 5

**8.08.3 Removal of Water**

The trench shall be kept free from water during excavation, fine grading, pipe laying and jointing. Dewatering sufficient to maintain the ground water level below the pipe grade shall be accomplished before pipe laying and jointing. The dewatering operation shall be carried out so it does not destroy or weaken the strength of the soil under or alongside the trench.

DEWATERING REQUIRES A STATE DEWATERING PERMIT AND A DEWATERING PLAN APPROVED BY AURORA WATER ENVIRONMENTAL INSPECTIONS DIVISION PER SECTION 4.06 OF THESE REGULATIONS.

**THIS PAGE IS INTENTIONALLY BLANK**

## **SECTION 9.00 PIPE BEDDING, BACKFILLING AND COMPACTION**

- 9.01 GENERAL
- 9.02 GRANULAR BEDDING MATERIAL
- 9.03 COMPACTING GRANULAR BEDDING
- 9.04 COMPACTION OF ORDINARY BACKFILL MATERIAL WITHIN  
THE BEDDING SECTION
- 9.05 CLASSES OF BEDDING
- 9.06 ORDINARY BACKFILL MATERIAL
- 9.07 SELECT BACKFILL MATERIAL
- 9.08 COMPACTING GRANULAR BACKFILL MATERIAL
- 9.09 COMPACTING ORDINARY MATERIAL
- 9.10 COMPACTION TESTING
- 9.11 MAINTENANCE OF BACKFILL
- 9.12 CONSTRUCTION SITE RESTORATION

## **SECTION 9.00 PIPE BEDDING, BACKFILLING AND COMPACTION**

### **9.01 General**

The minimum class of bedding shall be determined from the appropriate section for the type of pipe specified. The Contractor may select a higher class bedding at his option. If he does not comply with the minimum bedding requirements, he must use the next higher class of bedding at no cost to the City.

Backfilling and compaction shall be performed when practicable after completion of all necessary inspections, or when authorized by the Engineer. The total length of open trenches shall not exceed 300 feet at anytime. Jetting or ponding as a means of compaction shall not be allowed. Backfill material which is above the optimum moisture content shall not be allowed in the trench until it has been properly dried to optimum moisture. Only soil with the proper moisture content shall be allowed as backfill material. Any procedure, required by the Engineer to process backfill material, shall be the Contractors responsibility. Unless otherwise specified, the Contractor at his expense shall dispose of all excess backfill off the rights-of-way and public property. Special care shall be taken to ensure proper compaction around valve boxes and manholes.

In general, the backfill material shall consist of material excavated from the trench except rubbish, frozen material, broken pavement, other debris, stones greater than three (3) inches in diameter, organic muck, or other materials considered deleterious by the Engineer. When in the opinion of the Engineer, the excavated material is not satisfactory for use as backfill, or whenever there is a shortage of satisfactory backfill material, the Contractor shall furnish all necessary suitable backfill material and shall dispose of the condemned excavated material at the Contractor's expense.



## 9.02 Granular Bedding Material

The bedding and pipe zone material shall be clean, free draining well-graded sand or squeegee sand and shall conform to the following limits when tested by means of laboratory sieves:

### Well Graded Sand

<u>Sieve Size</u>	<u>Total Percent Passing By Weight</u>
3/8 inch	100
No. 4	70-100
No. 8	36-93
No. 16	20-80
No. 30	8-65
No. 50	2-30
No. 100	1-10
No. 200	0-5

### Angular Squeegee Sand

<u>Sieve Size</u>	<u>Total Percent Passing By Weight</u>
3/8 inch	100
No. 200	0-3

Approved bedding and pipe zone material shall be stockpiled on the jobsite to be used in the event natural materials become unsatisfactory. Aurora Water reserves the right to require the use of specified bedding in the pipe zone at any time.

## 9.03 Compacting Granular Bedding

Granular bedding material shall be deposited in layers not exceeding twelve (12) inches in loose measured thickness. Each layer shall then be compacted by surface or internal vibrators, hand or power tampers, or other suitable compaction equipment. Layer thickness may be increased only if contractor can demonstrate that sufficient compaction can be achieved with the methods and equipment provided by the contractor. Each layer shall be compacted to the required degree of compaction before the placement of subsequent layers. Layer thickness shall be reduced if the compaction equipment and compaction effort does not provide the required degree of compaction. The material shall have a minimum compaction of 70% relative density as determined by ASTM D-4253.

## **9.04 Compaction of Ordinary Backfill Material within the Bedding Section**

Ordinary backfill material shall be deposited in layers not exceeding twelve (12) inches in loose measured thickness. Each layer shall then be compacted by surface or internal vibrators, hand or power tampers, or other suitable compaction equipment. Layer thickness may be increased only if contractor can demonstrate that sufficient compaction can be achieved with the methods and equipment provided by the contractor. Each layer shall be compacted to the required degree of compaction before the placement of subsequent layers. Layer thickness shall be reduced if the compaction equipment and compaction effort does not provide the required degree of compaction.

Compacted ordinary backfill material consisting of A1 to A5 soils shall have a minimum compaction of 95% of the maximum dry density determined by AASHTO T180. A6 and A7 soils shall have a minimum compaction of 95% of maximum dry density determined by AASHTO T99.

## **9.05 Classes of Bedding (Methods)**

### **9.05.1 Class A Bedding**

(Concrete Cradle) Class A bedding shall be defined as the method of bedding in which the lower half of the pipe is set in reinforced concrete. The minimum thickness of concrete under the lowest part of the conduit shall be 1/4 of the outside pipe diameter, but not less than 6 inches. The concrete shall extend upward around the pipe to the spring line of the pipe barrel. The concrete cradle shall be a minimum of 6 inches thick in all places. Reinforcement shall be #4 deformed bars twelve (12) inches laterally and longitudinally on centers in the middle of the slab. Backfill materials shall be hand compacted to a minimum depth of one foot above the pipe.

### **9.05.2 Class B Bedding**

Class B bedding shall be defined as the method of bedding in which the pipe is set on compacted granular bedding material. The trench shall be excavated to a depth below the established grade equal to 1/4 of the outside diameter, but not less than 6 inches. In rock excavation, the minimum depth shall be 6 inches. Granular bedding material shall be placed and compacted under the pipe and around the sides of the pipe to spring line. The granular bedding material shall be consolidated and compacted as required in Section 9.03.

### **9.05.3 Class B Alternate Bedding**

The same requirements shall apply as in Class B bedding but granular material shall be placed to a depth of one (1) foot above the pipe. This bedding condition shall be used for all ASP,

PVC and HDPE pipe installations. This method may also be used at the Contractor's option or shall be required by the Inspector if the Contractor cannot meet the compaction requirements using ordinary backfill material to one (1) foot above the pipe.

#### **9.05.4 Class C Bedding**

Class C bedding shall be defined as the method of bedding in which the pipe is set on compacted granular bedding material supporting the lower quadrant of the pipe barrel. The trench shall be excavated to a depth below the established grade equal to 1/8 of the outside pipe diameter, but not less than 6 inches. Compacted granular material shall be placed under the pipe and around the sides of the pipe to a minimum of 1/6 of the outside pipe diameter from the bottom of the pipe barrel. The granular bedding material shall be consolidated and compacted as required in 9.03. Ordinary backfill material shall be compacted to one (1) foot above the pipe as required in 9.04.

#### **9.05.5 Class D Bedding**

(Flat Bottom) Class D bedding shall be defined as the method of bedding in which the pipe is placed on a flat bottom trench which supports the pipe barrel throughout its length. Bell holes shall always be provided and the bells shall be kept free of foreign material. Ordinary backfill material shall be hand compacted under the haunches of the pipe and to a minimum depth of one (1) foot above the pipe.

### **9.06 Ordinary Backfill Material**

Ordinary backfill material shall be material excavated from pipe line trenches on the site which is free from frozen materials, large amounts of organic material or other objectionable materials. Clays and similar materials with a plasticity index greater than 20 shall not be considered suitable for backfilling within one (1) foot of the pipe.

### **9.07 Select Backfill Material**

Select backfill shall be used under roadways whenever ground water is encountered within three (3) feet of the surface. Select backfill shall be road base crushed or pit run gravel all of which passes a one (1) inch sieve and not more than 30 percent passes a No. 40 sieve.

### **9.08 Compacting Granular Backfill Material**

Granular backfill material shall be deposited in layers not exceeding twelve (12) inches in loose measured thickness. Each layer shall then be compacted by surface or internal vibrators, hand or power tampers, or other suitable compaction equipment. Each layer shall be compacted to the required degree of compaction before the placement of subsequent layers. Layer thickness shall be reduced if the compaction equipment and compaction effort does not provide the required

degree of compaction. Layer thickness may be increased only when sufficient compaction tests are provided to the Engineer which verifies a piece of equipment can compact to a depth exceeding twelve (12) inches. The material shall be compacted to a minimum of 95% of maximum dry density as determined by AASHTO T180 or, 70% of relative density as determined by ASTM 2049, whichever is greater. The time and depth of testing are at the discretion of the Inspector and shall be in accordance with Section 9.10 of these specifications.

### 9.09 Compacting Ordinary Material

Ordinary backfill shall be placed from one (1) foot above the pipe to the surface, except as required in Section 9.03. Ordinary backfill material shall be deposited in layers not exceeding twelve (12) inches in loose measured thickness. Each layer shall then be compacted by surface or internal vibrators, hand or power tampers, or other suitable compaction equipment. Each layer shall be compacted to the required degree of compaction before the placement of subsequent layers. Layer thickness shall be reduced if the compaction equipment and compaction effort does not provide the required degree of compaction. Layer thickness may be increased only when sufficient compaction tests are provided to the Engineer which verifies a piece of equipment can compact to a depth exceeding twelve (12) inches. Compacted backfill shall be placed to a minimum depth of thirty (30) inches above the top of the pipe before a vibratory roller or a compacting hammer is used over the pipe. Ordinary backfill in Public Right-of-Way shall be compacted as follows:

<u>Soil Type</u>	<u>Compaction</u>	<u>Moisture Content</u>
A-1 thru A-5	95% max. dry density <sup>1</sup>	±2 percent optimum moisture content
A-6 & A-7	95% max. dry density <sup>2</sup>	0 to +2 percent moisture content

The backfill may be tested at any depth and shall be properly compacted at all depths. The time and depth of testing shall be at the discretion of the Inspector and in accordance with Section 9.00 of these specifications.

### 9.10 Compaction Testing

The compaction of the bedding and the backfill shall be tested at a rate of at least one (1) test per 200 cu. yd. of fill material or portions thereof and at least one (1) test per 250 lineal feet, whichever controls. The testing shall be at varying depths and locations. The Inspector may require additional testing around manholes and valve boxes. The Contractor shall also have one test provided to the City for every 3 water or sanitary service lines.

---

<sup>1</sup>As determined by AASHTO T180

<sup>2</sup>As determined by AASHTO T99

Initial test results shall be submitted by the Contractor to the materials lab within twenty-four (24) hours of the test or on the next City working day. Compaction testing shall be performed by a qualified technician who works under the direct supervision of a Registered Professional Engineer. Final soils compaction reports shall be prepared and signed by a Registered Professional Engineer who is registered in the State of Colorado and is qualified to prepare such reports. Reports shall be submitted to the C.O.A. Materials Testing Laboratory for review and approval within one (1) week of the test. All reports shall identify the appropriate utility extension agreement permit number and shall include a map showing the location of tests taken both vertically and horizontally along the utility trench. Compaction testing on private infrastructure shall be performed by private engineering or geotechnical firms at the Contractor/Developer's expense and submitted to the C.O.A. Materials Testing Laboratory for review and approval.

### **9.11 Maintenance of Backfill**

All backfill during construction shall be maintained to the satisfaction of the Engineer. Access across trenches for driveways and streets shall be maintained free of hazards to traffic or pedestrians.

### **9.12 Construction Site Restoration**

Upon completion of backfilling, the surface shall be restored fully to a condition equal to or better than what existed before construction. Final grades in unimproved areas shall match existing grades at construction limits without producing drainage problems. Restoration of native grasses per City of Aurora Rules and Regulations Regarding Stormwater Discharges Associated with Construction Activities shall be necessary unless otherwise specified. Restoration of sod, shrubs, trees and other landscaping shall be at the Contractor's expense. All sod, shrubs, trees and other landscaping shall be replaced with material of equal or better size and quality. Reseeding of sodded areas shall not be allowed unless specified. All work within improved areas shall be in accordance with Section 6.00 of these specifications and City of Aurora Rules and Regulations Regarding Stormwater Discharges Associated with Construction Activities. The cost of replacement work and removal of all debris from the site of the work shall be at the expense of the Contractor.

**THIS PAGE IS INTENTIONALLY BLANK**

## **SECTION 10.00 MANHOLES, VAULTS AND INLETS**

- 10.01 MATERIALS
- 10.02 CONSTRUCTION
- 10.03 MANHOLE BASES AND CHANNELS
- 10.04 HORIZONTAL JOINTS
- 10.05 EXISTING MANHOLES
- 10.06 WATER SYSTEM MANHOLES AND VAULTS
- 10.07 SANITARY SEWER SYSTEM MANHOLES
- 10.08 STORM SEWER SYSTEM MANHOLES AND INLETS
- 10.09 REFERENCE MARKERS

## **SECTION 10.00 MANHOLES, VAULTS AND INLETS**

### **10.01 Materials**

The materials to be used in the construction of manholes shall conform to the following requirements.

#### **10.01.1 Cones**

All cones shall be eccentric and conform to ASTM C-478.

#### **10.01.2 Precast Manholes and Vaults**

Precast manholes and vaults must be manufactured in conformance with ASTM Designation C478. The internal diameter of the manhole barrel shall be as specified on the approved plans.

#### **10.01.3 Precast Manholes and Vault Bases**

Precast manhole and vault bases are prohibited for public sanitary sewer and storm sewer systems. Channels in public manholes and vaults are required to be shaped at time of installation in the field. Private sanitary and storm facilities are allowed to utilize pre-cast manhole bases with channels and inlets. Precast manhole bases shall be constructed with reinforcement in accordance with ASTM C-478.

#### **10.01.4 Cast in Place Manholes**

Cast in place manholes are not allowed, however vaults may be cast in place.

#### **10.01.5 Cast in Place Vaults**

Cast in place vaults require structural design by a Colorado Registered Professional Engineer to meet AASHTO HS-20S requirements.

#### **10.01.6 Brick**

Brick manholes are not allowed.

#### **10.01.7 Concrete**

All concrete work shall conform to the requirements of Section 30 of the City of Aurora Roadway Design Standards and Specifications.

#### **10.01.8 Manhole Steps**

Sanitary sewer and storm sewer manholes do not require manhole steps. Storm sewer inlets and vaults require steps per Standard Detail #105.



### 10.01.9 Frames and Covers

Manhole frames and covers shall conform to the table below. The manhole frame and cover shall be as shown in the standard details. The cover shall be machined to fit the frame to exclude surface water and be level with the top of the frame. Covers shall have no more than one lifting slot which must not extend beyond the lip of the frame.

**TABLE FOR FRAME AND COVERS**

TYPE OF FACILITY	DESCRIPTION	SIZE OF FRAME AND COVER
WATER	1 ½" and 2" Meter Vault	24"
	3" and Larger Meter Vault	36"
	Butterfly Valve Vault	24"
	PRV or Check Valve Vault	36" with 22" Removable Lid
SANITARY SEWER	21" and Smaller Pipes	24"
	24" and Larger Pipes	30"
STORM SEWER	All	24"

The frame shall be secured through placement on mortar. Mortar shall be placed over the frame from the edge of the support structure to one (1) inch from the top edge of the frame for manholes not located within a pavement section.

Manholes placed within areas designated by the Department as "restricted access", shall have a locking lid with the rim permanently bolted to the manhole cone section. See Approved Materials List for approved products and manufacturers.

### 10.01.10 Flexible Joint sealing Compound

Flexible joint sealing compound material shall be used in all concrete barrel and base joints. Sealing compounds shall conform to Federal Specifications SS-S-00210 and shall remain pliable to -20 degrees Fahrenheit and shall not become excessively pliable at +120 degrees Fahrenheit. See Appendix B: Approved Materials List for approved products and manufacturers.

In locations of high groundwater joints between precast manhole sections shall consist of double O-ring rubber gaskets conforming to ASTM C443 or butyl rubber gaskets conforming to AASHTO M198. A 6-inch minimum width of butyl rubber coating shall be applied on exterior of manhole at each joint to prevent leakage. See Appendix B: Approved Materials List for

approved products and manufacturers.

#### **10.01.11 Job Mixed Grout**

Job mixed grout shall be one part Portland Cement conforming to ASTM C207, one part sand conforming to ASTM C144, and one part shrinkage correcting aggregate. See Appendix B, Approved Materials List for accepted manufacturers.

#### **10.01.12 Hydrogen Sulfide Resistance**

All sanitary sewer manholes on mains larger than 12 inches in diameter shall be constructed with, or lined with, hydrogen sulfide resistant materials. Aurora Water Engineering may require lining on smaller sized systems with high probabilities of hydrogen sulfide generation. Hydrogen sulfide resistant lining shall be applied to a minimum thickness of 60 mils. See Appendix B: Approved Materials List for approved products and manufacturers.

### **10.02 Construction**

Manholes shall be installed and constructed in conformance with ASTM C891. They shall be constructed at the locations and elevations indicated on the drawings. The manhole barrels shall be watertight at all joints including the base.

All manholes six and one half (6-1/2) feet deep measured from the bench to the top of the cone shall be constructed with an eccentric cone. All manholes less than six and one half (6-1/2) feet deep shall be constructed with a flat top over the outlet invert per Detail #101 unless otherwise stated on the plans or directed by the Engineer in writing. Minimum clearance from any block-out or core drilled opening to the top of a barrel section is 3 inches. The top of cone or top of flat lid section shall not extend to a point closer than eight (8) inches and no more than eighteen (18) inches from the top of the manhole cover. Precast concrete adjustment rings shall be used on top of the cone or flat lid to support and adjust the manhole frame to the required final grade.

The fillet of the manhole ring is to be filled with mortar to a minimum of one (1) inch beyond the fillet.

Flexible joint sealing compound conforming to Section 10.01.10 of these Specifications shall be applied to all manhole joints, to all precast vault joints, and between manhole frames and the top of the manhole. The application of the priming compound and the sealing compound shall be accomplished in strict conformance with the manufacturer's instructions. The joint materials shall conform to the approximate manufactured shape at the time of installation. Any materials not conforming shall be rejected and not used. The joint materials shall not be stretched or in any way distorted.

The internal diameter of all manholes shall be maintained from the manhole base to a distance of not more than five (5) feet below finished grades. From the point 5 feet below finished grade to the surface the manhole barrel shall be tapered to the appropriate frame and cover manhole diameter for the appropriate system.

Manholes placed within newly constructed areas shall be placed to final grade prior to the placement of the final lift of asphalt. Cast iron riser rings are not allowed for adjustment of new manholes. Submittal and approval of manhole riser rings shall be required to ensure conformance with City of Aurora standards.

### **10.03 Manhole Bases and Channels**

Manhole bases, unless noted otherwise on the drawings, shall be constructed as shown on the standard manhole detail drawings. All manhole bases cast in the City of Aurora must be placed using an iron manhole forming ring sized for the appropriate sized manhole base. In the event the subgrade has been over excavated, granular bedding material shall be used and compacted per Section 9.00 of these rules and regulations, and approved by the Inspector to bring the subgrade to final elevation.

Changes in direction of flow through the manhole shall be made with a smooth curved channel having as large a radius as possible. The change in size of channels shall be made gradually and evenly and shall be formed directly in the concrete. In addition, the grade and pipe curvature of the primary channel shall be maintained throughout the length of the channel. The floor of the manhole, outside the channel, shall be finished to a smooth surface and shall be slightly sloped to allow a worker to comfortably stand on the bench. The concrete depth for the channel shall measure no less than 4 inches thick at the flow line.

The minimum thickness of the base shall not be less than 8 inches under the invert of the manhole channel for a cast-in-place base. Manhole base diameters shall be 2 feet greater than the outside diameter of the manhole barrel section. The walls of the base shall be no less than 12 inches thick. The joint between the manhole base and the lowest pre-cast section shall be grouted, inside and outside, with a grout fillet.

### **10.04 Horizontal Joints**

Flexible plastic joint sealing compound in conformance with Section 10.01.10 of these Specifications shall be applied to all manhole joints. The application of the priming compound and the sealing compound shall be accomplished in strict conformance with the manufacturer's instructions. The joint materials shall conform to the approximate manufactured shape at the

time of installation. Any materials not conforming shall be rejected and not used. The joint materials shall not be stretched or in any other way distorted.

Manhole joints shall be smooth finished with non-shrink grouting material per Section 10.01.11 of these Specifications.

Sanitary and storm sewer manholes constructed in areas of high groundwater level shall be constructed with joints using double butyl rubber plastic gaskets and exterior wrap in accordance with the Standard Detail #101.

### **10.05 Existing Manholes**

All penetrations to an existing manhole shall be accomplished by core drilling and installing Link Seal or approved equivalent, then grouting around inside and outside of penetration. The existing concrete foundation bench shall be chipped to the cross-section of the new pipe to form a smooth continuous invert similar to what would be formed in a new concrete base. Cement grout shall be used as necessary to finish the new invert smoothly and to seal the new line so the junction is watertight. All manhole steps and landing platforms' access doors shall be aligned for the entire depth of the manhole.

Within existing paved areas, manhole frames and covers can be adjusted up to 3 inches vertically with cast iron riser rings. Neither aluminum nor plastic riser rings are permitted. Concrete rings are required for adjustments greater than 3 inches, as long as the final rim elevation is no further than 24 inches from the first step.

### **10.06 Water System Manholes and Vaults**

Manholes shall be constructed which allow for operation of all valves from above ground with a four and one half (4-1/2) foot valve key. All valve vaults shall be designed adequately to house the valves and fittings therein contained and to withstand all external loadings imposed by earth, thrust, and AASHTO H-20S loading. Vaults shall be furnished with removable roof slabs or manholes of sufficient size to allow removal of all valves and fittings and shall be fitted with air vents open to the atmosphere. Vaults shall be constructed according to the approved drawings and these Specifications.

### **10.07 Sanitary Sewer System Manholes**

Service lines shall not empty directly into a manhole unless the manhole has been specifically and exclusively constructed for the service line. Clean-outs shall not, under any circumstance, be allowed in place of a manhole. For manhole spacing and sizing criteria see Section 5.06 and 5.07. For acceptable drops through manholes see Section 5.03.

The use of external drop manholes for sanitary systems shall only be allowed on a case-by-case basis due to upstream conflicts. Prior to approval of a drop manhole, the Design Engineer must provide alternatives for review and consideration by Aurora Water Engineering. External drop manholes may be approved by the Water Department when the incoming flow-line invert elevation is 18 inches or greater, above the downstream/out flow-line invert elevation. Internal drop manholes are not allowed in the City

Sewer pipe connections to existing manholes, if there is no existing pipe stubbed out, shall be made so the finished work shall conform as nearly as practicable to the essential requirements specified for new manholes. The Contractor shall take precautionary measures to ensure no tools, concrete, dirt, or debris of any kind is allowed to fall into the channel of the existing manhole by placing a protective cover over the bench. The Contractor shall be responsible for any cleaning or removal of debris from downstream sewer as a result of his/her work.

### **10.08 Storm Sewer System Manholes and Inlets**

Inlets shall be constructed at the locations and to the elevations specified on the drawings. Construction shall be in accordance with the standard drawings for Curb Opening Inlet. The edge of the access opening shall be located no more than 18 inches from the inside face of the outlet pipe. In no case shall outfall pipes be placed vertically in the floor of the inlet. Pipe penetrations may not be through the corners of a precast inlet.

Drop manholes are allowed, however require special design if velocities exceed 18 feet per second. Drop manholes exceeding 30 inches of vertical drop require approval on a case-by-case basis.

### **10.09 Reference Markers**

Whenever a manhole is outside a traveled street or walkway, a reference marker shall be installed per Standard Detail #220 and placed within 2 feet of the appurtenance.

**THIS PAGE IS INTENTIONALLY BLANK**

## **SECTION 11.00 WATER PIPE INSTALLATION**

- 11.01 GENERAL
- 11.02 PROGRESSION OF WORK
- 11.03 ALIGNMENT
- 11.04 EXCAVATION, BEDDING AND BACKFILLING
- 11.05 FITTINGS AND SPECIALS
- 11.06 WET TAPS
- 11.07 RUBBER GASKET JOINTS
- 11.08 CRADLES AND ENCASEMENTS FOR UTILITY  
CROSSINGS
- 11.09 THRUST RESTRAINT
- 11.10 THRUST BLOCKS
- 11.11 CORROSION PROTECTION
- 11.12 DISINFECTION OF WATER LINES
- 11.13 FLUSHING THE LINE
- 11.14 PRESSURE TEST

## **SECTION 11.00 WATER PIPE INSTALLATION**

### **11.01 General**

Water lines shall be installed according to the following specifications. The more stringent requirements shall govern in case of a conflict.

- American Water Works Association Standard C200
- American Water Works Association Standard C600
- American Water Works Association Standard C900
- American Water Works Association Standard C905
- The City of Aurora Standards and Specifications Regarding Water, Sanitary Sewer and Storm Drainage Infrastructure, latest edition
- The Water Works Manufacturer Recommendations.

### **11.02 Progression of Work**

Pipe shall be laid accurately to the grade and alignment specified on the drawings. Blocking or wedging of the pipe to achieve proper positioning and grade shall not be permitted, except where required for the proper construction of cradles or encasement. When pipe placement is not in progress, all open ends of pipe shall be closed by a mechanical watertight plug. Plywood shall not be permitted as a substitute. The cutting of pipe for insertion of fittings or closure pieces shall be done neatly without damaging the pipe coating or lining and so as to leave a smooth end at right angles to the long axis of the pipe. Flame cutting of pipe shall not be allowed. The Contractor shall provide for strutting and bracing of steel pipe to avoid damage and excessive deflection as required by the Engineer. Supports shall be of adequate strength with ends conforming to the curvature of the pipe. Ends shall be sufficiently padded to prevent damage to the lining.

THE CONTRACTOR SHALL BE RESPONSIBLE FOR NOTIFICATION OF AFFECTED USERS IF HIS/HER WORK CAUSES ANY DISRUPTION IN SERVICE.

### **11.03 Alignment**

All pipes shall be constructed to the lines, grades and elevations shown on the approved drawings. The minimum cover on all water mains shall be 4-½ feet. Water mains 16 inches in diameter and larger shall be strictly laid to approved grades to allow proper installation of air relief and air vacuum valves and blow-off valves. All pipes shall be laid to straight lines as staked between specified and otherwise authorized angles, bends or points of tangency of horizontal or vertical curves.



DEFLECTION AT FIELD JOINTS SHALL NOT EXCEED THE MAXIMUM DEFLECTION RECOMMENDED BY THE PIPE MANUFACTURER. JOINT DEFLECTIONS ARE NOT ALLOWED ON PVC PIPE.

#### **11.04 Excavation, Bedding and Backfilling**

Bedding for water lines shall be well graded sand per Section 9.02 of these Specifications. Excavation is specified in Section 8.00 of these Specifications. Backfilling and compaction is specified in Section 9.00 of these Specifications.

#### **11.05 Fittings and Specials**

Fittings and specials shall be installed as detailed on the drawings and shall be properly anchored against thrust and uplift forces.

#### **11.06 Wet Taps**

Wet taps are performed on live water mains by Aurora Water for the purpose of water main extensions, fire hydrant laterals, private fire suppression lines, and water services larger than 2 inches. Contractor is responsible for paying the wet tap fee and scheduling the tap at least 24 hours in advance with Customer Service at 303-326-8645. Wet taps will only be performed if the temperature is a minimum of 32 degrees Fahrenheit and rising.

Excavation for wet tap shall have shielding or shoring on all side including headwall and rear of excavation. When multiple utility conflicts prevent a shoring box from being used, hydraulic speed shoring is acceptable. Shielding or shoring shall extend a minimum of 18 inches above finish grade.

For Bolt-on saddles for tapping DIP and PVC mains, excavation area inside the shoring or shielding shall extend 3 feet behind the pipe, 6 feet on the wet tap side of the pipe, and be a minimum of 4 feet in width. A minimum of 1 foot of clear area below the pipe is required. For weld-on applications on steel pipe, excavation area inside the shoring or shielding shall extend 6 feet on the wet tap side of the pipe and be 6 feet in width. These taps do not require material to be removed from the back side of the pipe. Minimum clear area beneath the pipe for weld-on applications shall be 2 feet.

Contractor shall provide a ladder for entry and exit extending a minimum of 3 feet vertically

above existing grade.

If contractor fails to meet the above criteria, Aurora Water personnel will not enter the excavation and wet-tap will need to be re-scheduled.

## **11.07 Rubber Gasket Joint**

Rubber gasket joints shall be according to ANSI/AWWA C111/A21.11 and these Specifications.

### **11.07.1 Lubricant**

The lubricant shall be suitable for lubricating the parts of the joint in assembly. The lubricant shall be nontoxic, shall not support the growth of bacteria, and shall have no deteriorating effects on the gasket material. It shall not impart taste or odor to water in the pipe. The lubricant containers shall be labeled with the trade name or trademarks and the pipe manufacturer's name. The lubricant shall be supplied by the pipe manufacturer and approved by the Inspector.

### **11.07.2 Gaskets**

Gaskets shall always be protected from damage and contamination. Gaskets displaying any imperfection in manufacturing, any damage, or any contamination shall not be used.

### **11.07.3 Installation**

All surfaces in contact with the rubber gasket shall be thoroughly cleaned to be free of all visible contamination immediately prior to installation. All contaminants, excess coating, rust or any other foreign material shall be removed from the gasket groove and the spigot end.

## **11.08 Cradles and Encasements for Utility Crossings**

Temporary supports consisting of concrete blocks or bricks shall be used to support pipe in place before placing concrete for cradles or encasement. Not more than two supports shall be used for each pipe length, one beside the shoulder of the bell and the other near the spigot end. Water main shall be double-wrapped with polyethylene tubing within cradles or encasements and reinforcing steel bars shall not be allowed to be in contact with the pipe.

### **11.08.1 Storm Sewer Crossing over Water or Sanitary Sewer**

A minimum clearance of 18 inches is required whenever a storm sewer crosses over a water or sanitary sewer main. If 18 inches of clearance cannot be maintained, a concrete cradle shall be installed per Standard Detail #402. In no case shall vertical clearance between storm sewer pipe

and sanitary sewer or water pipe be less than 6 inches. In cases where vertical clearance is less than 18 inches insulation may be required as determined by Aurora Water Engineering.

### **11.08.2 Water Crossing over Sanitary Sewer**

A minimum clearance of 24 inches is required whenever a water main crosses over a sanitary sewer. Concrete encasement of the sanitary sewer shall be required if the clearance is less than 24 inches and shall be installed per Standard Detail #100. Encasement shall extend 10 feet either side of the crossing for a total length of 20 feet.

### **11.08.3 Sanitary Sewer Crossing over Water**

Sanitary mains and services are not allowed to cross over water lines without the approval of the Engineer and site specific design of the crossing.

### **11.08.4 Water or Sanitary Sewer over Storm Sewer**

Concrete cradles or encasements are not required whenever a water main or sanitary sewer main crosses over a storm sewer unless required by the Engineer.

## **11.09 Thrust Restraint**

Water main restraint shall be required at all fittings requiring protection from unbalanced thrust forces per Standard Details #221, #222 and #223. Specifically, vertical and horizontal bends or offsets, dead-ends, bulkheads, tees, 3 inch and larger domestic connections, branches, fire protection lines and fire hydrants. Fire hydrant laterals and fire suppression lines are required to be restrained for their entire length. Allowable restraint products are listed in Appendix B: Approved Material List.

## **11.10 Thrust Blocks**

In addition to joint restraint, all bends, tees, fire hydrants, main wet taps, plugs and plugs with blowoffs at dead-ends, shall require protection from thrust using thrust blocks per Standard Detail #221. Poured concrete thrust blocks must be cured 24 hours before backfill unless otherwise permitted by the Engineer. Thrust blocks may be backfilled prior to 24 hours of cure time if high-early strength concrete is used which can attain strength of 2500 psi within 4 hours after placement. A polyethylene barrier shall be required at all points where concrete is in direct contact with the pipe and/or fittings. This requirement applies to all pipe materials.

Concrete thrust blocks shall be sized for the internal pressure of the pipeline and the load bearing capacity of the soil. The internal water pressure used for design shall be 200 psi minimum for

water mains smaller than 16 inches in diameter. The static line pressure plus 150 psi shall be used for water mains 16 inches or larger. In no case shall the internal design pressure for thrust restraint be less than surge pressure as recommended in the AWWA Manual M11. Concrete thrust blocks shall be Type II (or IIA). Thrust blocks shall always bear against undisturbed earth. If in the opinion of the Engineer, the soil bearing capacity is not sufficient to provide adequate restraint (based on a minimum soil bearing capacity of 2000 psf), bearing area shall be increased to a size which shall ensure adequate restraint.

Gravity blocks are required at all downward vertical bends.

### **11.11 Corrosion Protection**

Insulation shall be provided between dissimilar materials in all cases except air vacuum assemblies. Ductile iron pipe and all fittings shall be wrapped in polyethylene tubing according to ANSI/AWWA C105/A21.50 and these Specifications to prevent corrosion. Pipe shall be double-wrapped within encasements or cradles. Corrosion Protection for all water mains shall be according to Section 20.00 of these Specifications.

### **11.12 Disinfection of Water Lines**

All potable water lines shall be disinfected prior to being placed into service or tapped. Rechlorination shall be required if the main is not tested within 30 days of initial filling or is not placed into service within 30 days of testing. Disinfection shall be accomplished by the Chlorine Concentration Test followed by the Bacteria Test, as hereafter specified. The City of Aurora Water Quality Laboratory or an authorized representative will conduct all chlorine and bacteria testing. Chlorination shall be performed according to AWWA C651 and these Specifications.

ONLY CITY OF AURORA WATER DIVISION PERSONNEL SHALL OPERATE VALVES IN CONTACT WITH THE CITY OF AURORA WATER SYSTEM. ANY OTHER PERSON WHO OPERATES A VALVE IN CONTACT WITH POTABLE WATER IS SUBJECT TO FINES UNDER THE CITY OF AURORA MUNICIPAL CODE.

#### **11.12.1 Chlorine Concentration Test**

The Chlorine concentration shall be tested at accessible locations and as required by Aurora Water personnel. This includes, but is not limited to, fire hydrants, blow-offs, and stub lines. Chlorine shall be tested by either Amperometric Titration or N,N Diethyl-1,4 Phenylenediamine Sulfate (DPD) Test. Orthotolidine colorimetric testing is not an acceptable method of testing the chlorine concentration.

### 11.12.2 Tablet Method

Calcium Hypochlorite Tablets shall be used for chlorination when contamination control has been exercised during installation of the pipe. 48 hours of contact time is required. Installed water mains shall not be flushed before chlorination. The tablet method shall not be used when trench water or foreign materials have entered the waterline. If the water temperature is less than 41°F (5°C), the water shall remain in the pipe for at least 48 hours. The tablets shall be secured to the pipe wall by use of AWWA approved adhesive products. The tablets shall be placed at the top of the water line after installation of the pipe and the pipe shall be marked to assure the tablets are so located.

#### 11.12.2.1 Number of Tablets

Once a water line has been filled, the concentration of chlorine shall be at least 25 milligrams per liter at all test locations and after 24 hours, the chlorine concentration shall be at least 25 milligrams per liter. Using the following table should produce the required concentrations using 3-1/4 grams available chlorine per 5 gram tablet under normal conditions.

NUMBER OF TABLETS PER PIPE SECTION

Length of Section(feet)	Diameter of Pipe				
	4"	6"	8"	12"	16"
13 or less	1	2	2	5	9
18	2	3	4	6	12
20	2	3	4	7	14

#### 11.12.2.2 Filling the Line

The line shall be filled with potable water at a velocity of less than 1 ft/sec. When the line is full, all valves shall be operated to ensure total chlorination.

ONLY CITY OF AURORA WATER DIVISION PERSONNEL SHALL OPERATE VALVES IN CONTACT WITH THE CITY OF AURORA WATER SYSTEM. ANY OTHER PERSON WHO OPERATES A VALVE IN CONTACT WITH POTABLE WATER IS SUBJECT TO FINES UNDER THE CITY OF AURORA MUNICIPAL CODE.

### 11.12.3 Continuous Feed Method

This method shall be used if flushing the water line before chlorination is necessary or if the tablet method fails.

#### 11.12.3.1 Application of Chlorine

Water from the existing distribution system shall be made to flow at a constant rate through the line to be disinfected. Chlorine is then pumped into the line at the source of fresh water at a rate resulting in a chlorine concentration of at least 50 milligrams per liter measured at all accessible locations and as required by the Aurora Water representative. All valves shall then be operated to insure total chlorination. After remaining in the line for 24 hours, the chlorine residual shall be not less than 10 milligrams per liter measured at all accessible locations and as required by the Aurora Water representative. The following table should meet these requirements under normal conditions.

CHLORINE REQUIRED TO PRODUCE A CHLORINE  
CONCENTRATION OF 50 MG/L PER 100 FT. OF PIPE:

Pipe Size	100 Percent Chlorine (Lb.)	1 Percent Chlorine Solution (Gal)
4"	0.027	0.33
6"	0.061	0.73
8"	0.108	1.30
10"	0.170	2.04
12"	0.240	2.88
16"	0.434	5.20

### 11.12.4 Slug Method

The slug method shall only be used for large mains when the continuous feed or tablet methods are not practical.

#### 11.12.4.1 Chlorine Application

Chlorine shall be applied continuously at a rate so all interior surfaces shall be exposed to a concentration of at least 100 milligrams per liter of chlorine for at least 3 hours per

AWWA C651-86. All valves, fire hydrants and blow-offs shall be operated to ensure total chlorination. 24 hours of contact time is required.

#### **11.12.4.2 Flushing the Line**

The line shall be flushed until the chlorine residual at all required locations is less than 1 milligram per liter or system residual. When discharging water during the flushing process, care shall be taken to prevent erosion or the killing of desirable vegetation during the flushing process.

#### **11.12.5 Special Conditions**

Precautions shall be taken to avoid contamination when water mains are cut into or repaired. If water mains are cut into or repaired and there is no interruption of service, continuous feed or slug method may be used at the discretion of the Aurora Water Engineering Inspector. If significant service interruptions are imminent, the tablet method and 24 hour chlorine contact time is allowed at the direction of the Inspector. Swabbing shall be required in the event of a service interruption and at final tie-ins. The Inspector will provide direction for proper and applicable procedures. When isolation of the section of line is possible, the continuous feed or slug method of chlorination shall be used, followed by and preceded by thorough flushing. The absolute minimum disinfection procedures shall include swabbing of all couplings, tapping sleeves and any other materials to be used with a 5 percent Sodium Hypochlorite solution (commercial Clorox or equivalent) or a 350 MG/L available Chlorine solution made from Calcium Hypochlorite [One 5g tablet of Calcium Hypochlorite (70% available Chlorine) per 10 liters of water is equal to 350 MG/L of available Chlorine] immediately prior to being installed.

#### **11.12.6 Bacteria Test**

Following chlorination, all treated water shall be thoroughly flushed from the pipe line at its extremities until the replacement water throughout its length shall, upon testing, be proved comparable in quality to the water served the public from the existing water supply system as approved by the City of Aurora. If there are undesirable bacteria present, the line shall be re-chlorinated and re-flushed as directed by the Inspector.

### **11.13 Flushing the Line**

When the chlorine test has been successfully completed, the water line shall be flushed until the chlorine residual is less than 2.5 milligram per liter. Water lines shall be flushed at a velocity of at least 2.5 feet per second through the line. Flushing shall be performed after the tablet method but before the continuous feed method. Flushing shall always be performed before bacteria

testing. Flushing of lines shall be accomplished by using a fire hydrant pumper nozzle when possible. Both hydrant side nozzles must be used together for flushing when using a hydrant.

Contractor is responsible for any permitting required by Colorado Department of Public Health and Environment prior to flushing the line. The contractor must follow flushing procedures outlined in the approved Storm Water Management Plan (SWMP). If no SWMP is required, contractor shall flush water line per instructions of the Inspector.

### **11.14 Pressure Test**

The trench shall be backfilled after the pipe has been installed and visually inspected; the pipe shall then be filled with water and ALL AIR EXPELLED. If hydrants or blow-offs are not available at high points, the Contractor shall make the necessary taps at high points to expel the air and insert plugs after the air is expelled. The hydrostatic test pressure shall be 200 psi at the lowest point in the line or section under testing and shall be maintained for at least two hours. Water lines with butterfly valves shall be tested to a line pressure of 150 psi. The Contractor shall apply pressure in a manner satisfactory to the Engineer and shall furnish all testing apparatus.

Leakage shall be defined as the quantity of water which must be supplied into the newly laid pipe, or any valved section thereof, to maintain the specified leakage test pressure after the air in the pipe line has been expelled and the pipe has been filled with water. No pipe installation shall be accepted if the leakage is greater than determined by the formula:

$$L = \frac{SD\sqrt{P}}{148000} \quad \text{for PVC and DIP lines.}$$

For mechanical joints and push-on joints; in which L is the allowable leakage, in gallons per hour; S is the length of the pipeline tested, in feet; D is the nominal diameter of the pipe, in inches; and P is the average test pressure during the leakage test in pounds per square inch gauge.

For steel lines the leakage shall not exceed 10 gallons per inch diameter per 24 hours per mile.

Note: Any visible leaks despite the rate of leakage shall be repaired before acceptance. Newly constructed water lines shall not be left in service during acceptance procedures for the purpose of detecting possible leaks. It is the Contractor's responsibility to re-pressurize the main as necessary while isolating the new main from the existing distribution system.



## **SECTION 12.00 DUCTILE IRON (DIP) WATER LINE**

- 12.01 GENERAL
- 12.02 DIAMETER OF PIPE
- 12.03 PRESSURE CLASS DESIGN OF PIPE
- 12.04 GRADE OF IRON
- 12.05 PIPE LENGTHS
- 12.06 FITTINGS AND SPECIALS
- 12.07 FIELD JOINTS
- 12.08 PROTECTIVE COATINGS
- 12.09 CATHODIC PROTECTION
- 12.10 INSTALLATION

## **SECTION 12.00      DUCTILE IRON (DIP) WATER PIPE**

### **12.01 General**

All material, manufacturing operations, testing, inspection and marking of ductile iron pipe shall be in conformance with the requirements of ANSI/AWWA C151/A21.51.

### **12.02 Diameter of Pipe**

The diameter shown on the drawings shall mean the nominal inside diameter of the pipe.

### **12.03 Pressure Class Design of Pipe**

The minimum pressure class for each section of the pipe line shall conform to ANSI/AWWA C150/A21.50 Specifications for the specified Laying Condition and for 250 psi minimum working pressure. The following are the minimum allowable pressure classes of pipe which may be installed.

<u>Pipe Size</u>	<u>Pressure Class</u>
12" & smaller	Class 350
larger than 12"	Class 250

### **12.04 Grade of Iron**

The grade of iron shall be 60-42-10 having a minimum tensile strength of 60,000 psi, minimum yield strength of 42,000 psi, and a minimum elongation of 10%.

### **12.05 Pipe Lengths**

Pipe sections shall be furnished in not less than eighteen (18) foot nominal lengths with the exception of bends, reducers, closure pieces, and specials which may be of shorter lengths.

### **12.06 Fittings and Specials**

Fittings shall conform to ANSI/AWWA C153/A21.53 and may be either cast iron or ductile iron. Fittings shall be Class 350 through 12 inch lines, and Class 250 for 16 inch and larger lines. The designer shall furnish, for approval by the Engineer, details for all specials and other fittings not covered by ANSI /AWWA C153/A21.53. All fittings shall be either flanged or mechanical joints. Restrained joint pipe shall be used whenever the main is installed through a casing sleeve.



may be prolonged (2-10 days).

Material: The polyethylene material shall be of virgin polyethylene.

Tape: Polyvinyl chloride based with high tack adhesive.

Additional corrosion preventative measures or different pipe material may be required by Aurora Water Engineering where soil resistivities are less than 1000 ohm-centimeters.

### **12.09.1 Installation of Polyethylene Tubing**

Prior to installation of polyethylene tubes, clumps of mud or other contaminants shall be brushed off the pipe surface. Polyethylene tubes shall be installed according to ANSI/AWWA C105/A21.5 Method A. Method A requires the tubes to be overlapped 1 foot and secured with tape, and the slack width to be taken up on top of the pipe and taped at the quarter points. All rips, punctures or other damage to the polyethylene shall be repaired with tape or with a short piece of tubing cut open, wrapped around the pipe and secured in place.

## **12.10 Installation**

Pipe shall be installed according to AWWA C600 and in accordance with any special requirements of the Engineer.

### **12.10.1 Trench Width**

The maximum trench width shall be the outside diameter of the pipe plus three (3) feet. Whenever the allowable trench width is exceeded, the Engineer shall be notified. Any improved bedding required by the Engineer shall be at the expense of the Contractor. Minimum clearance between the pipe and the trench wall shall be eight (8) inches.

### **12.10.2 Bedding**

Pipe shall be bedded according to the bedding class noted on the plans. In no case will the bedding class be less than Class B Alternate. Compaction shall be according to Section 9.00 of these Specifications.

## **SECTION 13.00 STEEL WATER LINE**

- 13.01 GENERAL
- 13.02 DIAMETER OF PIPE
- 13.03 WALL THICKNESS DESIGN OF PIPE
- 13.04 GRADE OF STEEL
- 13.05 SHOP TEST PRESSURE
- 13.06 LINING
- 13.06 FITTINGS AND SPECIALS
- 13.07 FIELD JOINTS
- 13.08 INSTALLATION
- 13.09 CATHODIC PROTECTION

## **SECTION 13.00 STEEL WATER PIPE**

### **13.01 General**

Steel pipe shall be installed as specified on project drawings and specifications. All material, manufacturing operations, testing, inspection and marking of steel pipe shall be in conformance with the requirements of AWWA C200, 203, 205, 206 and AWWA manual M11, *Steel Pipe – A Guide for Design and Installation*.

### **13.02 Diameter of Pipe**

The diameter indicated on the drawings shall mean the outside diameter of the pipe for sizes under 30 inches and shall mean the inside diameter for sizes 30 inches and larger.

### **13.03 Wall Thickness Design of Pipe**

The wall thickness of steel pipe shall be designed in accordance with the criteria established in AWWA manual, M11. The minimum wall thickness for each section of the pipe line shall conform to the thickness indicated on the drawings, and shall be subject to approval by the Engineer. The pipe with stiffeners, if any and the compacted soil in the bedding section shall form a structure of such stiffness so the vertical deflection of the embedded pipe shall not exceed 2% of the outside diameter of the pipe when subjected to the design loads.

### **13.04 Grade of Steel**

The grades of steel used in making pipe and fittings shall be those specified in AWWA C200.

### **13.05 Shop Test Pressure**

The minimum shop test pressure for pipe and fittings shall be in accordance with AWWA C200.

### **13.06 Lining**

All pipe will be concrete lined per AWWA specifications and handled so no cracks or damage is done to the pipe or lining. Any cracks more than 1/16" in width in the concrete lining will be repaired per AWWA Standards and the pipe manufacturers recommendations. On piping 22 inches in diameter, and larger interior joints with gaps more than 1/16" will be hand grouted per AWWA recommendations. Piping smaller than 22 inches in diameter will be grouted with the ball and burlap method according to AWWA specifications. All internal joints will be videotaped to verify the joint is adequately grouted

## **13.07 Fittings and Specials**

Unless noted otherwise on the project drawings, fittings shall conform to the dimensions of AWWA C208 for service in piping systems for water works. Pipe used in fittings shall be of the same material and minimum thickness as the pipe. Fittings shall be equal in pressure design strength and shall have the same lining and coating as the abutting pipe. Fittings, unless otherwise noted on the project drawings, shall be made of segmental welded sections, with bands to mate the type of joint or coupling used. Fittings which cannot be mechanically lined and coated shall be lined and coated by hand, using the same materials as those used for the pipe and in accordance with applicable AWWA Standards.

## **13.08 Field Joints**

### **13.08.1 General**

The following types of joints shall be acceptable: welded joints, mechanically coupled joints, or push-on joints. Flanged joints shall be acceptable for pipe on supports.

### **13.08.2 Welded Joints**

Welded steel pipe joints shall be as indicated in these Specifications. For butt-welded joints, the end of the pipe section being laid shall be carefully aligned with the open end of the previously installed pipe, moved longitudinally until both pipe ends are in contact, and a fitting-up jig attached. For lap-welded slip joints, the spigot of the piece being laid shall be inserted into the bell of the previously installed pipe. No welding shall be done until the temperature of the pipes connected is uniform and approximately the same throughout their circumference. If necessary welding shall be done at night, or the pipes shall be protected from the rays of the sun, or other precautions adopted. Where welded pipeline joints are used, at intervals of not more than 400 feet, a slip joint shall be provided with 4 inch longitudinal adjustment, as described in AWWA C206. After the joint is welded, the unprotected area of the pipe shall be cleaned and field lined and coated in accordance with AWWA C203 and/or C205 to the thickness specified for the pipe.

### **13.08.3 Mechanically Coupled Joints**

Mechanically coupled joints shall be used on steel pipe only as indicated on the approved plans (see Appendix B: Approved Materials List). The thickness of middle rings shall be the same as the pipe on which the joint is installed. The grade of steel used shall meet the requirements for steel used for the pipe. Middle rings shall be fabricated to properly fit the outside diameter of the pipe on which the joint is installed. Middle and follower rings shall be cleaned and primed after fabrication. Pipe stops shall not be provided on middle rings of

mechanically coupled joints adjacent to line valves. Joint bonding shall be required on mechanically coupled joints.

The ends of the pipe on which couplings are to be placed and the couplings themselves shall be clean and free from any dirt or foreign matter, especially those surfaces of the pipe and coupling which come in contact with the gaskets. Gaskets shall be kept clean with no foreign matter between them and the facing surfaces. Wrenches used in bolting couplings shall be of a type and size recommended by the coupling manufacturer. Coupling bolts shall be tightened to the manufacturer's specified torque. Coupling bolts shall be so tightened as to secure uniform annular space between the follower rings of the housing-clamps and the body of the pipe. All bolts shall be tightened to the same torque with all parts of the coupling square and symmetrical with the pipe. After installation, primed couplings shall be carefully touched up or reprimed if necessary.

Insulating couplings and/or flanges shall be installed in the steel pipeline to facilitate future cathodic protection at locations indicated on the drawings or as directed by the Engineer.

#### **13.08.4 Bell-and-Spigot Joints**

Bell-and-Spigot joints for steel water lines shall be allowed only with written permission from Aurora Water. Bell-and-Spigot joints shall be stab type joints consisting of a rubber gasket bell and spigot. Interior dimensions of the joint shall be the same as those of the pipe. Gasket materials shall conform to the requirements of AWWA C200. The joints shall be designed to remain water tight under all service conditions, including expansion, contraction, and earth settlement. The gasket shall not support the entire weight of the pipe. Spigot ends shall have a groove to retain the gasket. Pipe ends shall be self-centering without the aid of the gasket. A rust inhibitor protective coating, which is compatible with the material used for pipe lining, shall be applied to the interior surface of the bell and the exterior surface to the point where the spigot enters the bell.

### **13.09 Installation**

Pipe shall be installed in accordance with AWWA manual M11 and in accordance with any special requirements of the Engineer.

#### **13.09.1 Trench Width**

The maximum trench width shall be the outside diameter of the pipe plus three (3) feet. Whenever the allowable trench width is exceeded, the Engineer shall be notified. Any improved bedding required by the Engineer shall be at the expense of the Contractor. There shall be a minimum clearance between the pipe and the trench wall of 8 inches.



### **13.09.2 Bedding**

Pipe shall be bedded in accordance with the bedding class noted on the plans. Under no circumstance shall the bedding class be less than Class C. Compaction shall be in accordance with Section 9.00 of these Specifications.

### **13.10 Cathodic Protection**

Cathodic protection is required per Section 20.00 of these Specifications.

**THIS PAGE IS INTENTIONALLY BLANK**

## **SECTION 14.00 POLYVINYL CHLORIDE (PVC) WATER LINE**

- 14.01 GENERAL
- 14.02 MATERIALS
- 14.03 FITTINGS AND SPECIALS
- 14.04 DIAMETER OF PIPE
- 14.05 STORAGE OF PIPE
- 14.06 SUNBURNED PIPE
- 14.07 INSTALLATION

## **SECTION 14.00 POLYVINYL CHLORIDE ( PVC) WATER PIPE**

### **14.01 General**

PVC pipe shall comply with either AWWA C900 for pipe sizes 4 inch through 12 inch and C905 for pipe sizes 14 inch or above and shall be clearly marked on each section of pipe. All pipe shall be suitable for use as a pressure conduit.

PVC WATER MAIN SHALL BE REQUIRED FOR USE WHEN RESISTIVITY TESTS OF THE SURROUNDING SOIL ARE LESS THAN 1000 OHM-CENTIMETER.

### **14.02 Materials**

All PVC pipe used for water main within the City of Aurora shall be Pressure Class 305 and shall conform to the requirements of DR 14. Furthermore, PVC pipe shall be furnished in cast-iron pipe equivalent outside diameters. The bell shall consist of an integral wall section with an elastomeric ring meeting the requirements of ASTM F477. The wall thickness in the bell section shall conform to the requirements of ASTM D-3139 with all measurements made according to ASTM D2122. Pipe shall also meet the National Sanitation Foundation Standard No. 61 and shall be furnished in 20 foot laying lengths.

### **14.03 Fittings and Specials**

Fittings and specials shall be cast or ductile iron and conform to Section 12.06 of these Specifications. All fittings shall be epoxy coated fittings, double wrapped with 8 mil polyethylene extended for one foot and tightly taped on both sides of fitting. Anodes for fittings shall be applied only at the discretion of Aurora Water Corrosion Engineer.

### **14.04 Diameter of Pipe**

The diameter shown on the drawings shall mean the nominal inside diameter of the pipe.

### **14.05 Storage of Pipe**

All pipe ends shall be capped at the factory prior to being shipped. Pipe arriving onsite without the ends capped shall be rejected. Pipe shall be stored in a way that shall protect the pipe from damage due to exposure to sunlight.

## **14.06 Sunburned Pipe**

Pipe discolored to any extent shall be considered as having sunburn damage and shall be rejected and removed from the project.

## **14.07 Installation**

Pipe shall be installed according to AWWA Standard C900/A.1.1.3 and according to these Specifications.

ALL PVC WATER PIPE SHALL BE INSTALLED WITH AN ELECTRONIC MARKER SYSTEM FOR LOCATING PURPOSES. TRACING WIRE IS NOT ALLOWED. SPIGOT SHALL NOT BE INSERTED IN THE BELL PAST THE HOME LINE INDICATED ON THE SPIGOT OR THE ENTIRE INSTALLATION SHALL BE REJECTED. JOINT DEFLECTION ON PVC PIPE IS NOT ALLOWED WITHOUT THE APPROVAL OF AURORA WATER ENGINEERING.

### **14.07.1 Trench Width**

The maximum trench width shall be per Section 8.02 of these Specifications. Whenever the allowable trench width is exceeded, the Engineer shall be notified. Any improved bedding required by the Engineer shall be at the expense of the Contractor. Minimum clearance between the pipe and the trench wall shall be 8 inches.

### **14.07.2 Bedding**

Class B Alternate bedding as described in Section 9.00 of these Specifications shall be the minimum class of bedding used for PVC pipe. Compaction shall be according to Section 9.00 of these specifications.

### **14.07.3 Electronic Marker System**

PVC water pipe shall be installed with electronic markers at a spacing of one marker for every 60 lineal feet of pipe, and at every tee, bend or deflection in the pipe. These markers shall be blue in color and as manufactured by 3M Scotchmark or approved equal. Mid-range markers shall be used for waterlines less than 6 feet in depth, and full range markers shall be used for any portions of waterlines greater than 6 feet in depth.

**THIS PAGE IS INTENTIONALLY BLANK**

## **SECTION 15.00 WATERLINE VALVES**

- 15.01 GENERAL
- 15.02 INSTALLATION
- 15.03 GATE VALVES
- 15.04 BUTTERFLY VALVES
- 15.05 PRESSURE REDUCING AND REGULATING VALVES
- 15.06 CHECK VALVES
- 15.07 AIR AND VACUUM VALVES
- 15.08 BLOW-OFF VALVES
- 15.09 VALVE BOXES
- 15.10 VALVE VAULTS
- 15.11 REFERENCE MARKERS

## **SECTION 15.00 WATERLINE VALVES**

### **15.01 General**

All valves shall be manufactured according to AWWA Standard C500 and shall open by turning clockwise (RIGHT). Valve ends shall be mechanical joint or flanged ends and shall be equipped with 2 inch square operating nuts. Valves and flanges shall be Class 200 unless otherwise specified. All valve operating nuts shall extend to within 4 feet of finished grade. No valves less than 4 inches in diameter shall be installed on the public main. Valve boxes shall be located no less than 3 feet from electrical, cable, telephone or gas lines and no less than 2 feet from cross pans, valley or gutter pans, or curb and gutter.

### **15.02 Installation**

Valves in water mains shall be installed, where possible, at a point on the main which would be intersected by an extension of a property line. Valves shall be installed so the operator is in a vertical position and can be operated from above ground. Valves shall be adjusted to seat properly.

### **15.03 Gate Valves**

Gate valves shall be used on all lines 12 inches and less in diameter. All gate valves shall be manufactured according to AWWA Standard C500, (Resilient Seat-AWWA C-509) and shall be either resilient seat or double-disc, parallel seat, iron body, bronze mounted, non-rising stem, equipped with "O"-ring stem seals and shall open by turning clockwise (RIGHT). All interior surfaces on resilient seat valves shall be epoxy coated according to AWWA C-550. Valve ends on resilient seat valves shall be mechanical joint. Valve operators shall be covered with a buffalo type valve box 5 ¼ inches in diameter. The word "WATER" shall be cast in the valve box cover. For gate valves allowed for use within the City of Aurora see Appendix B: Approved Materials List.

### **15.04 Butterfly Valves**

Butterfly valves shall be used in sizes 16 inch and larger and shall conform to Specification AWWA C504. Refer to Appendix B: Approved Materials List for the models approved for use in the City of Aurora. All interior surfaces on butterfly valves shall be epoxy coated according to AWWA C-550. Butterfly valves shall be furnished with mechanical or flanged end connections and shall be suitable for buried service installation. Butterfly valves shall be installed per



Standard Detail #212. Butterfly valves shall be adjusted to ensure they shall seat completely and shall not leak. All valves shall open clockwise (RIGHT). All butterfly valves shall have seating rubber in the valve body and not in the metal disc or be epoxy-coated at the factory.

Butterfly valves must be independently bench tested and certified to 150 psi prior to installation. Both side of the valve are required to be individually tested for 10 minutes. Any observed leaks shall constitute a failed test and the valve shall be returned to the manufacturer. Butterfly valves installed without first undergoing testing and certification are subject to removal at the contractor's expense. Aurora Water reserves the right to witness testing upon notification of contractor. The contractor should allow for sufficient time to test valves prior to requiring the approved valve at the work site.

### **15.05 Pressure Reducing and Regulating Valves**

Pressure reducing and regulating valves shall be of a type capable of maintaining pre-adjusted downstream pressures with varying rates of flow and upstream pressure without causing water hammer. Refer to Appendix B: Approved Materials List for models approved for use in the City of Aurora. Pressure reducing and regulating valves shall be installed in specially designed concrete valve vaults. Pressure reducing and regulating valves shall be of the flanged, globe body, fully bronze mounted, external pilot operated, diaphragm type with the following requirements:

- Have flanged cast iron bodies of 200 psi Class and be epoxy-coated both internally and externally. Stainless Steel bolts shall be used for externally epoxy-coated flanges.
- Be designed and constructed so as to facilitate repairs and internal dismantling without removal of valve from pipe line.
- Be constructed of new, first quality materials and components throughout including inlet and outlet gauge test ports.
- Be constructed so as to provide easy access to the pilot(s) and to allow pilot(s) removal while main valve is under pressure.
- Be furnished with all necessary pilot(s), blocking valves, needle valve(s), strainer(s), sight glass indicators and control piping.
- A gate valve or butterfly valve shall be installed on each side of a pressure regulating valve outside the vault. Mechanical couplings are required at the valve for butterfly valve installations.

## **15.06 Check Valves**

Check valves shall be installed in all cases to preserve the integrity of the water system. The valve shall seal tightly when the discharge pressure is greater than the inlet pressure and permit flow when the discharge pressure is less than the inlet pressure. Check valves shall be hydraulically operated by line pressure, and shall be of the diaphragm globe type. All necessary repairs other than the replacement of the valve body shall be possible without removing the valve from the line.

Check valves shall be installed in precast concrete manholes or vaults and fitted with air vents open to the atmosphere according to Standard Detail #213. Gate valves shall be located on either side of the manhole or vault as specified in Section 10.00 of these Specifications. See Appendix B; Approved Materials List for approved valves.

## **15.07 Air and Vacuum Valves**

Combination air and vacuum release valves shall be installed at each high point in all water mains of 16 inch diameter and larger. Air and vacuum release assemblies require six feet of vertical clearance from grade to the top of the pipe.

Air and vacuum release valves shall be installed in precast concrete manholes or vaults fitted with air vents open to the atmosphere with approved frost lid ring and cover assemblies in accordance with Standard Detail #211. See Appendix B; Approved Materials List for approved valves.

## **15.08 Blowoff Valves**

Blow-off hydrant per Standard Detail #209 is required at the end of mains extended into cul-de-sacs. Temporary blow-offs shall be installed in those portions of the water mains, which can not be chlorinated, flushed or tested by other means. Larger water mains (16" or larger) may require larger diameter blow-off assemblies and shall be installed according to Standard Detail #210 with right-hand open valves.

Blow-off assemblies consist of all valves, pipe and material necessary to install the blow-off valve complete in place.

## **15.09 Valve Boxes**

All gate valves shall be provided with a 5-1/4 inch cast iron screw type, Buffalo style valve box. The valve box shall be of a design which shall not transmit shock or stress to the valve and shall be centered and plumb over the operating nut of the valve, with the box cover flush with the surface of the pavement. See Appendix B: Approved Materials List for approved manufacturers and products.

## **15.10 Valve Vaults**

All valve vaults shall be designed to adequately house the valves and fittings therein contained as well as to withstand all external loadings imposed by earth, thrust, and AASHTO H-20S loading. Vaults shall be furnished with removable roof slabs or manholes of sufficient size to allow removal of all valves and fittings, shall be constructed in such a manner as to allow operation of all valves from above ground, with a 4 ½ foot valve key and shall be fitted with air vents open to the atmosphere. Vaults shall be built in accordance with the approved drawings and these Specifications. Air/Vac Vaults shall have approved frost lid ring and cover assemblies.

## **15.11 Reference Markers**

Whenever a valve is located outside of a traveled street or walkway, a reference marker shall be installed 3 feet from the valve box. The reference marker shall be a 3 inch galvanized pipe filled with dirt and capped with concrete. The pipe shall be 5 feet long, set in at least an 8 inch diameter hole a depth of 2 feet and filled with concrete. The pipe shall be painted fire hydrant yellow. Reference information shall be painted on the reference marker per Standard Detail #220. Anode and test site markers shall be marked with a marking post per Section 20.02 of these Specifications.

Valve Boxes not located within a pavement section shall be provided with an 18 inch square by 4 inch deep concrete collar.

**THIS PAGE IS INTENTIONALLY BLANK**

## **SECTION 16.00 FIRE HYDRANTS**

- 16.01 GENERAL
- 16.02 HYDRANT DETAILS
- 16.03 INSTALLATION
- 16.04 TESTING
- 16.05 FIRE HYDRANT LOCATION
- 16.06 FIRE HYDRANT SPACING
- 16.07 RELOCATIONS

## **SECTION 16.00 FIRE HYDRANTS**

### **16.01 General**

All fire hydrants shall conform to AWWA Standard C502. Dry barrel hydrants with drain valves are the only type of hydrants allowed in the City of Aurora. All fire hydrants shall have a 5½ foot bury depth. Fire hydrants with up to 7 feet bury depth shall be allowed by utilizing barrel extensions with a 5½ foot barrel only. In no case shall the bury depth exceed 7 feet. Vertical bends shall be used to adjust the bury depth to 5½ feet if the 7 foot maximum bury depth cannot be achieved. A fire hydrant shall consist of all valves, piping and materials necessary to install the hydrant in conformance with these Specifications. See Appendix B: Approved Materials List for approved products and manufacturers.

### **16.02 Hydrant Details**

#### **16.02.1 Hydrant Nozzle Openings and Operating Nut**

Hydrants shall have 2 hose nozzles, each measuring 2½ inches on the inside diameter and each having National Standard threads. All hydrants shall have one pumper nozzle measuring 4½ inches on the inside diameter, having Denver Standard threads 6 threads per inch, stainless steel fasteners on all stem components, and shall have bronze to bronze main valve seats. The main hydrant valve opening shall be 5¼ inches. The operating nut and nozzle caps shall be pentagon shaped and measure 1½ inch from point to the opposite flat.

#### **16.02.2 Color**

All hydrants shall be painted fire hydrant yellow according to AWWA C502.

#### **16.02.3 Coatings**

All hydrants shall have epoxy coatings according to Section 20.03.6 of these Specifications unless otherwise approved by Aurora Water Engineering. Epoxy coating shall extend to the hydrant's lower valve plate and include the foot valve housing.

### **16.03 Installation**

#### **16.03.1 Hydrant Drainage**

A minimum of 1/3 cubic yard of ¾" to 1" clean river rock shall be installed around the foot of the hydrant to facilitate proper drainage of the hydrant. The rock shall be covered with a sheet of 8 mil polyethylene. See Detail #208.

### **16.03.2 Hydrant Orientation**

The hydrant shall be plumbed and installed so the pumper nozzle faces the street or firelane as noted on the approved project drawings. The City of Aurora Life Safety Division shall determine the direction of proposed fire hydrant installations.

### **16.03.3 Traffic Safety Flange**

The traffic safety flange must be not less than 2 inches nor more than 6 inches above the finish grade. Mounding of landscape material around the hydrant is not allowed. Furthermore, no more than one riser 18 inches in height maximum shall be allowed on a hydrant at the time of acceptance.

### **16.03.4 Grade Staking**

All fire hydrants must be staked to finish grades unless curb and gutter has already been installed. Fire hydrants shall be installed according to Standard Detail #208.

### **16.03.5 Hydrant Laterals**

The piping from the main to the hydrant shall be no less than 6 inches in diameter and all piping shall be according to these Specifications. All piping shall be DIP or PVC according to Section 12.00 or Section 14.00 of these Specifications unless otherwise approved by Aurora Water Engineering. The fire hydrant shall be harness Mega-lugged to the main according to Section 12.00 of these Specifications and shall have a thrust block according to Standard Detail #208. Fire hydrants fed by a PVC lateral require a concrete support beneath the hydrant base per Standard Detail #208. 90 degree bends are not allowed on fire hydrant laterals.

Each fire hydrant shall have a 6 inch gate valve on the lateral pipe. The valve shall be designed and installed in accordance with Section 15.00 of these Specifications. The valve shall be located next to the water main supplying the fire hydrant. All water system valves and fire hydrants shall open to the **RIGHT**.

## **16.04 Testing**

All fire hydrants shall be tested and disinfected according to Section 11.00 of these Specifications. Any hydrant failing to drain properly shall be reinstalled to permit proper drainage.

## **16.05 Fire Hydrant Location**

In general, all fire hydrants shall be unobstructed on the street side and shall be located not less

than 3'-6" nor more than 8 feet from the back of curb to the center line of the hydrant. Minimum length of fire hydrant laterals is five feet. Minimum clearance on all sides shall be 5 feet. See the following criteria for specific location requirements. In no case shall fire hydrants be located within sidewalks, bike paths or handicap ramps.

#### **16.05.1 Attached 10 Foot Wide Bike Path**

Fire hydrants shall be located 1 foot from the edge of an attached 10 foot wide bike path (11 feet from the back of curb). If the fire hydrant is located further than 2'-6" feet from the edge of the bike path (13'-6" from the back of curb), the hydrant shall be relocated to 1 foot from the edge of the bike path.

#### **16.05.2 Attached 8 Foot Wide Bike Path**

Fire hydrants shall be located 1 foot from the edge of an attached 8 foot wide bike path (9 feet from the back of curb). If the fire hydrant is located further than 2'-6" from the edge of the bike path (10'-6" from the back of the curb), the hydrant shall be relocated to 1 foot from the edge of the bike path.

#### **16.05.3 Attached 5 Foot Wide Sidewalk**

Fire hydrants shall be located 1 foot from the edge of the sidewalk (6 feet from the back of curb). If the fire hydrant is located further than 3 feet from the edge of the sidewalk (8 feet from the back of curb), the hydrant shall be relocated to 1 foot from the edge of the sidewalk.

#### **16.05.4 Detached Sidewalk or Bike Path**

Fire hydrants shall be located no less than 3'-6" from the back of the curb to the centerline of the hydrant (18 inches from the edge of walk) when the sidewalk or bike path is detached from the curb by a 5 foot wide landscape buffer. No part of the hydrant is allowed to extend over the walk surface. If the fire hydrant is located closer than 3'-6" from back of curb to the centerline of the hydrant, or any part of the hydrant extends over the walk surface, the hydrant shall be relocated to 1 foot from the outside edge of the sidewalk.

#### **16.05.5 Landscaped Median Islands**

Fire hydrants located within 5 foot wide landscaped median islands shall be located 2'-6" from the back of curb to the centerline of the hydrant. In addition, the hydrant shall be located 3'-6" from the back of the curb at the nose of the median. If the hydrant is located less than 2 feet from the back of the closest, adjacent curb to the centerline of the hydrant, the hydrant shall be relocated to no less than 2'-6" from the back of the curb to the centerline of the hydrant.



Bollards may be required for these installations as necessary. Aurora Water Engineering shall determine bollard locations.

#### **16.05.6 Valley Pans or V-Section Streets**

Fire hydrants located on streets without vertical curb and gutter however with gutter pans or asphalt edges shall be located no less than 3'-6" and no further than 8 feet from the edge of concrete or asphalt to the centerline of the hydrant. If the fire hydrant is located closer than 3'-6" or further than 8 feet from the edge of the concrete or asphalt to the centerline of the hydrant, the hydrant shall be relocated to 3'-6" from the edge of the concrete or asphalt.

Bollards are allowed if in the opinion of the Engineer the hydrant is subject to damage by the travelling public, and require approval by the Engineer. All bollards shall be installed according to Standard Detail #208-2.

#### **16.06 Fire Hydrant Spacing**

Fire hydrant spacing shall not exceed the distance recommended in the International Fire Code as currently adopted by the City of Aurora.

#### **16.07 Relocations**

Fire hydrant relocations allowed only as expressly approved by Aurora Water Engineering. Hydrants over five years old must be replaced except as approved by Aurora Water Engineering. The entire fire hydrant lateral shall be required to undergo testing per Section 11.00. Aurora Water shall not be responsible for any testing failure due to the contractor using or testing against existing valves or hydrants.

**THIS PAGE IS INTENTIONALLY BLANK**

## **SECTION 17.00 WATER SERVICE LINES**

- 17.01 GENERAL
- 17.02 LOCATION AND ALIGNMENT OF SERVICE
- 17.03 MATERIALS
- 17.04 CROSSING OF SIDEWALK OR CURB
- 17.05 SERVICE STUB-INS
- 17.06 TAPPING THE MAIN
- 17.07 SERVICE LINE INSTALLATIONS
- 17.08 METER PIT INSTALLATIONS
- 17.09 MULTI-FAMILY METER INSTALLATIONS
- 17.10 RE-USE AND RELOCATION OF EXISTING METER PITS
- 17.11 DISCONTINUATION OF WATER SERVICE

## **SECTION 17.00 WATER SERVICE LINES**

### **17.01 General**

All water service line construction connecting to the City of Aurora Water Distribution System shall be constructed according to these Specifications. These Specifications shall cover all new water service line construction and repairs to existing lines from the water main to the building plumbing. Certificates of Occupancy (C.O.'s) shall not be issued prior to the meter set.

### **17.02 Location and Alignment of Service**

Water service lines shall be constructed on the shortest and straightest route possible. At no time shall the service line be any closer than five (5) feet to the side property line, and no service line may be constructed through or in front of any adjoining property. The service line shall be located ten (10) feet from the sewer service the entire distance from the point of connection at the water and sewer main to the building.

Water service lines shall not be permitted under the driveway without written permission of the Engineer. A PVC sleeve is required if a location under the driveway is approved.

### **17.03 Materials**

#### **17.03.1 Pipe**

All piping for 2 inch and smaller service lines shall be installed clean and shall be copper tubing type K either soft temper or hard drawn. Three inch or larger water service lines shall be Class 52 ductile iron pipe.

#### **17.03.2 Tapping Saddles**

Tapping saddles are required for **all** service taps on PVC and Asbestos Cement (AC) water main. Furthermore, saddles shall be required for all taps 1 1/2" or greater on 8" or smaller ductile iron pipe.

Tapping saddles shall be double-strap comprised of all bronze components including nuts, bolts, straps and body. See Appendix B: Approved Materials List for approved manufacturers and products.

#### **17.04 Crossing of Sidewalk or Curb (Existing or Proposed)**

In no instance shall a service trench extend beneath an existing sidewalk or curb. The pipe must be bored, or jacked through the earth, under the curb or sidewalk. The trench shall be backfilled according to Section 9.00 of these Specifications.

#### **17.05 Service Stub-Ins**

Service stub-ins shall extend at least to the curb stop or the meter pit. The meter yoke shall be installed as shown on the standard details.

#### **17.06 Tapping the Main**

The Contractor shall make 2 inch and smaller taps on the pressured main after testing, initial acceptance by the Aurora Water, and after payment of the water stub-out fee. The Contractor shall supply the tapping saddle, if necessary. The Inspector will inspect the tap, corporation stop and the service line from the main to the meter, for all service taps, prior to the contractor backfilling the service line trench. If the tap is backfilled prior to inspection, the contractor shall be required to expose the tap and service line for inspection.

Aurora Water will make water taps for 3 inch and larger service line installations on the main per Section 11.06 of these Specifications. These taps shall be no less than 4 inches in size.

No service taps shall be permitted on 24" diameter or larger transmission mains.

The remainder of the service line from the meter pit to the residence is then installed according to the standard details. An Inspector must make a visual inspection of the line before backfilling this portion of the line. Should the line be backfilled before an inspection, the Contractor shall expose the line for inspection. The request for inspection must be made 24 hours in advance.

#### **17.07 Service Line Installations**

All service line installation work shall conform to the standard details. Aurora Water will make the physical taps for all 3 inch and larger taps on the water main after it has passed inspection. Aurora Water will furnish and install the water meter once the applicable connection fees have been paid. The Applicant for the water service connection shall, at his sole expense, provide and install the trench, tap for 2 inch and smaller service lines, insulator, service line pipe, tapping saddle and meter yoke where required, check valve, meter pit or vault, meter pit or vault cover, and curb stops.

All water service lines are required to be dielectrically isolated from the mains.

All service lines shall be of uniform size from the service line tap to the building structure or structures except 3 inch meter connections which require 4 inch service lines, single family attached and detached residential services, or as otherwise approved by Aurora Water. Aurora Water reserves the right to require a larger service connection to any building, structure, or development if the water requirements, when calculated by the fixture unit method as specified in the Uniform Plumbing Code or the current adopted International Plumbing Code, cause the service line velocity to exceed 10 feet per second.

All bends in copper service lines shall have a minimum radius of twelve inches (12"). No lead soldered joints are allowed on any section of the water service lateral. Furthermore, field soldered joints are not allowed on the section of the water service lateral between the main and the meter pit.

Service lines larger than 2 inches in diameter shall be required to undergo testing per Section 11.00 from the main to the building water connection.

Wherever, a backflow prevention assembly is required by Aurora Water Engineering to prevent contamination of the public water supply through a specific service connection, such backflow prevention assembly of a type and design approved by Aurora Water shall be furnished and installed by the Owner/Developer. All non-residential water service taps and all fire service lines shall require a backflow prevention device which shall include, but not be limited to clubhouses, pools, churches, etc. Backflow prevention assemblies shall be installed per Section 19.00 of these Specifications.

### **17.08 Meter Pit Installations**

Meter pits shall be located in landscaped areas, within the public right-of-way or in a utility easement. In addition, meter pits shall be located such that a minimum of 2 feet of distance from the edge of the lid to the back of the nearest curb, sidewalk or valley pan according to the applicable standard detail. Meter pits shall not be installed in or under driveways, sidewalks, streets or parking areas. Meter pits shall be located away from hazards, i.e., steam vents, electrical equipment. Remote reading meters, where the meter is installed within the building foundation, are not allowed.

All materials shall be of new quality and free of defects.

Meter pits shall be staked in the field if curb and gutter are not installed. Lowering of meter pits shall not exceed 6 inches without adjusting the accompanying water service lateral. The meter pit shall be at final grade at the time the meter is to be installed. Any adjustment in the grade of the meter pit, meter yoke or brace shall be by and at the expense of the owner. Final grades may be evidenced by the presence of a curb and gutter. If curb and gutter is not present, the owner shall assume responsibility for adjusting meter pits and service laterals as necessary to conform with these Specifications.

Meter pits shall be vertically plumb.

Meter pits shall be constructed so the rings and hoods do not have spaces between them. The pits shall be free of trash and shall have a minimum depth of four feet (4') from finished grades. Hoods shall be raised with riser rings only and have a 2" (51mm) hole predrilled in the center of the hood lid for ¾" and 1" meters.

Backfill around a meter pit and in the trench shall be done according to Section 9.00 of these Specifications.

No meter will be installed until the installation is according to all Specifications.

### **17.09 Multi-Family Meter Installations**

Each building containing vertically stacked units in a multi-family development shall require a single meter for each building. Individual units separated only by a common vertical wall must have an individual service line and meter for each unit. Multiple meter vaults per Detail # 203 in single family attached developments may be allowed at the sole discretion of Aurora Water Engineering.

### **17.10 Reuse and Relocation of Existing Meter Pits**

For re-development sites with existing pits, an existing meter pit may only be re-used if it fully conforms to all applicable standards. The maximum allowable distance a meter pit may be relocated is ten (10) feet. Otherwise, the water main shall be re-tapped and the existing service connection shall be disconnected at the main.

## **17.11 Discontinuation of Water Service**

Whenever a building is torn down or removed, the service line shall be uncovered at the water main and the service corporation closed. A section of the service line one foot in length shall be removed at the corporation to disconnect the line physically and the threads shall be sawed off at the outlet. If a building permit has been obtained for another building in a location a shall use the same water service line, the service line shall only have to be switched off and locked in the meter pit. An Inspector will inspect the disconnection before backfilling the hole after a \$10.00 disconnection fee has been paid to the Tap Applications Office. Backfilling shall be according to Section 9.00 of these Specifications. For service line abandonments of 3 inch and larger services. The gate valve isolating the service from the public main shall be required to be removed and the tee blind-flanged.



**SECTION 18.00 AUTOMATIC FIRE SUPPRESSION SYSTEM**  
**WATERLINES**

- 18.01 OWNERSHIP
- 18.02 INSTALLATION
- 18.03 TESTING

## **SECTION 18.00 AUTOMATIC FIRE SUPPRESSION WATERLINE INSTALLATION**

### **18.01 Ownership**

Automatic fire suppression lines shall mean water lines used solely for serving the interior of a building with either automatic and/or manual fire extinguishing systems. The private fire suppression line shall start on the system side of the valve connecting it to the City water supply and end at the flange in the riser room.

TAPPING THESE LINES FOR FIRE HYDRANTS, DOMESTIC WATER AND/OR ANY OTHER PURPOSE SHALL NOT BE PERMITTED.

These lines shall be privately owned and maintained and in no manner shall be the responsibility of the City of Aurora.

Automatic fire suppression systems in single family detached residences only may be tapped from the domestic service. The potable water supply to automatic sprinkler and standpipe systems shall be protected against backflow by a double check-valve assembly or a reduced principle backflow preventer. All other construction shall require a separate fire suppression line from the domestic service.

### **18.02 Installation**

All fire service lines must be installed, in their entirety, by a National Fire Protection Agency (N.F.P.A.) certified Contractor. Licensing can be obtained from the Colorado Division of Fire Safety. In addition, approved civil plans from Aurora Water are required for all fire service line connections. The Contractor must present licenses and approved civil plans to Aurora Water before permits will be issued.

Fire service lines shall be installed per Standard Detail #223. All fire service lines shall be Ductile Iron (3 inch and larger) or type K copper (2 inch and smaller) from the main line to backflow assembly. Ductile iron fire service lines shall be completely restrained for the entire length.

Two inch and smaller fire service lines shall have a tee and 4 inch gate valve with a 2 inch or smaller threaded plug, copper service threaded union, and service insulator per Standard Detail

#223. Three inch or larger fire lines shall have a tee, 4 inch gate valve, and 4 inch by 3 inch reducer if necessary per Standard Detail #223.

All fire service lines shall be isolated from the City main by a gate valve at the point of connection. Under no circumstances shall the isolation valve be less than four inches in diameter. Valve boxes for fire suppression lines must have locking lids. This valve is considered public and shall be owned and operated by Aurora Water personnel only. On existing water mains the City of Aurora will provide the tee, valve, valve box and perform the four inch wet tap for all fire service lines after the applicable wet tap fees have been paid to the Tap Applications Counter at Aurora Municipal Center, 15151 East Alameda Parkway, Aurora, Colorado. Construction plans must be reviewed and approved by the Aurora Water prior to obtaining a permit.

### 18.03 Testing

Fire service lines shall undergo chlorine, pressure and bacteria testing per Section 11.00 of these Specifications with the exception of the hydrostatic pressure testing. This test shall be performed at 200 psi  $\pm$  5 psi and shall be maintained for 2 hours.

Once the fire line has passed initial testing, flow tests shall be conducted before connection is made to the sprinkler system piping. The current N.F.P.A 24 Manual ‘Standard for the Installation of Private Fire Service Mains and Their Appurtenances’ must be present on site and given to the inspector prior to the flow tests. The flushing operation shall continue for a sufficient time to ensure thorough cleaning. The minimum rate of flow shall be not less than one of the following:

- (1) The hydraulically calculated water demand rate of the system including any hose requirements.
- (2) The flow necessary to provide a velocity of 10 ft/sec (see table below)

Pipe Size	Flow Rate
Inches	gpm
4	390
6	880
8	1560
10	2440
12	3520

- (3) The maximum flow rate available to the system under fire conditions

These tests shall be subject to inspection by an N.F.P.A. certified inspector from the C.O.A. Building Division. The Contractor is required to call the Building Division at (303) 739-7420 no less than 48 hours in advance to schedule a flow test. All costs and equipment associated with the testing shall be the owner's responsibility.

## **SECTION 19.00 BACKFLOW PREVENTION ASSEMBLIES**

- 19.01 GENERAL
- 19.02 IRRIGATION SYSTEMS
- 19.03 FIRE SUPPRESSION SYSTEMS
- 19.04 INSTALLATION
- 19.05 TESTING AND MAINTENANCE

## **SECTION 19.00 BACKFLOW PREVENTION ASSEMBLYS**

### **19.01 General**

#### **19.01.1 Backflow Prevention Requirements**

All commercial facilities are required to install an approved backflow prevention assembly on their domestic water line, sprinkler irrigation systems, and fire sprinkler systems.

Building plans must be submitted, approved and permitted through the City of Aurora Building Division. Building Plans must show at a minimum:

- Water service type, size and location.
- Backflow prevention assembly manufacturer, size, type and location.
- Adequate drainage as needed if installed inside.
- Thermal expansion tank as required by code.
- Fire sprinkling system(s) service line, size and type of backflow prevention assembly if applicable.
- Irrigation system(s) service line, size and type of backflow prevention assembly.

If it becomes necessary to install a booster pump on the water service line to any consumer's premises due to low pressure or special operating conditions, such service lines shall be protected by the installation of an approved air-gap separation or an approved reduced pressure principle assembly.

#### **19.01.2 Ownership**

All costs for design, installation, maintenance, repair, and testing are to be borne by the owner or the party billed for water service.

#### **19.01.3 Existing Installations**

Backflow preventers currently installed, which are not approved shall be replaced with an approved backflow prevention assembly at the time: they fail an operational test; the assembly shall be replaced; or if the assembly is determined to be non-testable or no longer approved for the degree of hazard.

No grandfather clauses exist. All laws and regulations apply regardless of the age of the facility.

#### **19.01.4 Approved Backflow Prevention Assemblies**

Any backflow prevention assembly required herein shall be of a model and size approved by the Aurora Water Engineering. The term “Approved Backflow Prevention Assembly” shall mean an assembly manufactured in full conformance with the standards established by the latest version of the Colorado Cross-Connection Control Manual and/or by the Aurora Water Engineering.

A single check valve is not considered an approved backflow prevention assembly.

#### **19.01.5 Residential Services**

Backflow prevention in Single Family Detached and Single Family Attached buildings as defined by City Code for water service may be accomplished with an assembly not approved by the Foundation for Cross-Connection Control and Hydraulic Research, but approved by the American Society of Sanitary and Mechanical Engineers and designated by the Aurora Water Engineering.

Backflow prevention in Multi-Family buildings as defined by City Code for water service are required to follow commercial requirements for backflow prevention assemblies.

### **19.02 Irrigation Systems**

#### **19.02.1 Air-Gaps and Reduced Pressure Assemblies**

Irrigation and lawn sprinkling systems which permit the mixing, pumping, dissolution, injection, or siphoning of any foreign substance into the water, or any such system which incorporates the use of any booster pump(s), or which is subject to backpressure, shall be separated from the public potable water system by an approved air-gap separation or an approved reduced pressure principle assembly.

In any irrigation or lawn sprinkling system where the terrain makes the installation height of a pressure or atmospheric vacuum breaker assembly impractical, the public potable water system shall be protected by an approved reduced pressure principle assembly. A reduced pressure principle assembly may also be installed to serve multiple irrigation circuits in lieu of pressure vacuum breakers.

### **19.02.2 Pressure Vacuum Breakers**

In irrigation and lawn sprinkling systems not incorporating the use of an injection system or booster pump(s), a pressure vacuum breaker assembly may be used. Irrigation and lawn sprinkling systems having quick-coupling valves or other similar type heads permitting pressure to be retained in the system shall have a pressure vacuum breaker assembly installed on the system. Irrigation and lawn sprinkling systems using the subsurface drip method shall also have a pressure vacuum breaker assembly installed on the system.

### **19.02.3 Atmospheric Vacuum Breakers**

An atmospheric vacuum breaker assembly may be used when the irrigation or lawn sprinkling system does not incorporate an injection system or booster pump(s), and is not subjected to backpressure, continuous pressure or continuous flow. Atmospheric vacuum breakers shall only be installed on irrigation circuits with sprinkler heads which shall not return any pressure to, or retain any pressure in the circuit when the circuit control valve is closed.

## **19.03 Fire Suppression Systems**

### **19.03.1 Requirements**

All fire lines supporting a fire sprinkler system shall require an approved reduced pressure backflow prevention assembly or an approved double check backflow prevention assembly as required by the Aurora Water Engineering. Installation of a backflow prevention device can reduce the required operating pressure of the overall fire sprinkler system flow requirements. An evaluation of this potential effect must be evaluated by a qualified sprinkler contractor and submitted to a City of Aurora Life Safety representative within the Building Code Division (303-739-7420) for review and approval prior to installation.

Backflow Assemblies used on fire lines shall be listed by the National Fire Protection Association and/or UL Approved.

All glycol (ethylene or propylene), or antifreeze systems shall have an approved Reduced Pressure Zone assembly for containment upstream of the point of use.

Dry fire systems shall have an approved Double Check Valve installed upstream of the air pressure valve.



Single family residences with a combined domestic water and fire sprinkler system shall have a double check valve when no chemicals are used.

## **19.04 Installation**

### **19.04.1 Location and Design**

Backflow prevention assemblies are to be installed in an accessible location to facilitate maintenance, testing and repair. Building plans must show the location of the backflow prevention assembly.

Backflow prevention assemblies shall be installed downstream of the water meter before any other tee or branch. In no case shall it be permissible to have any connections or tees between the meter and service line backflow prevention assembly.

Backflow prevention valves are not to be used as the inlet or outlet valve of the water meter. Test cocks are not to be used as supply connections.

Approved backflow prevention assemblies shall be installed without any bypass, unless the bypass line is also protected by an approved backflow prevention assembly providing an equivalent degree of protection.

All backflow Assemblies shall be installed in the horizontal position. Vertical installations shall be acceptable when approved by University of Southern California Foundation for Cross Connection Control and Hydraulic Research and/or American Society of Sanitary Engineering Specifications. Variances may be granted by review.

Proper drainage should be provided for the relief valve and may be piped away from the location provided it is readily visible from above grade and provided the relief valve is separated from the drain line by a minimum of double the diameter of the supply line. Freezing is a major problem in this area. Precautions should be taken to protect above ground outdoor installations.

### **19.04.2 Basement Installations**

Basement installations are allowed providing the following conditions are met:

- Installation of a drain large enough to allow the maximum flow of discharged under twice the normal static water pressure for the assembly, and the installation of a high

water alarm system. Electrical systems and/or components shall not be installed in the same general area.

- The relief valve opening shall never have a water level under the assembly reach within a vertical distance of 12 inches of the relief valve discharge port. The relief valve discharge port shall be directed down.
- The relief valve discharge port on a reduced pressure principle assembly shall not be connected to any sump or sanitary sewer.
- Only factory supplied funnels shall be used to remove the periodic discharge from the assembly and the piping system must have an approved air-gap at the termination of the run.

#### **19.04.3 Pressure Vacuum Breakers**

Pressure vacuum breakers shall be used only where the assembly is never subjected to back pressure and shall be installed a minimum of twelve (12) inches above the highest piping or outlet downstream of the assembly in a manner to preclude back pressure.

#### **19.04.4 Atmospheric Vacuum Breakers**

Atmospheric vacuum breakers shall be used only where the assembly is installed as an isolation assembly and is never subject to more than 12 hours continuous backpressure. Atmospheric Vacuum Breakers shall be installed with the air inlet in a level position and a minimum of six (6) inches above the highest piping or outlet it is protecting.

#### **19.04.5 Double Check Valve Assemblies**

Double check valve assemblies may be installed in below grade vaults when these vaults are approved and properly constructed in accordance with Aurora Water Engineering requirements. They must be insulated to prevent freezing. They must have adequate clearance for testing and maintenance, and drainage should be provided for testing, flushing and repairs.

#### **19.04.6 Reduced Pressure Backflow Preventers**

Reduced pressure backflow preventers shall be installed above ground. The unit should be placed at least twelve inches (12) above the finish grade to allow clearance for repair work. A concrete slab at finish grade is recommended.

Reduced pressure principle assemblies shall not be installed in any below-grade pit or vault unless there is a drain sized twice the nominal pipe diameter of the assembly which gravity

discharges to daylight.

#### **19.04.7 Waterline Flushing**

Before installing an approved backflow prevention assembly, pipelines must be thoroughly flushed to remove foreign material.

### **19.05 Testing and Reporting**

#### **19.05.1 Testing requirements**

Backflow prevention assemblies are required to be tested at the time of installation, repair or replacement, and on an annual basis thereafter. Such tests shall be conducted in accordance with Article 12 of the Colorado Primary Drinking Water Regulations.

All testing equipment used in the testing of backflow prevention assemblies shall be checked for accuracy yearly, or more often, and proof of compliance shall be submitted to Aurora Water annually, or upon request.

Aurora Water retains the right to test or otherwise check the installation and operation of any containment assembly at any time to ensure proper operation.

The following testing laboratories are qualified to test and certify backflow prevention assemblies. Being listed on their periodic approved list shall constitute meeting the above requirements:

- American Society of Sanitary Engineering (ASSE), 901 Canterbury, Suite A, Westlake, OH 44145
- USC Foundation for Cross-Connection Control and Hydraulic Research, University of Southern California, KAP-200 University Park MC-2531, Los Angeles, CA 90089-2531

Backflow prevention assemblies shall be returned to service by the technician performing the test at the completion of the test.

#### **9.05.2 Reporting, Record-keeping Duties and Requirements**

The certified cross-connection control technician shall report on a form approved by the City, the results of tests and maintenance given to Aurora Water and the property owner. This report shall be submitted by the certified technician to Aurora Water within five (5) working days

following the completion of the test or maintenance of the assembly. The certified cross-connection control technician shall also, on a form approved by the city, attach a tag to the backflow prevention assembly following each test or maintenance activity to document and date the activities performed. Records of all tests or maintenance activities, including materials and parts changed, shall be kept by the certified cross-connection control technician, the property owner, and Aurora Water for a period of not less than three years.

## **SECTION 20.00 CORROSION CONTROL FOR WATER PIPE**

- 20.01 SOIL RESISTIVITY MEASUREMENTS
- 20.02 ANODE AND TEST SITE INSTALLATION
- 20.03 CORROSION CONTROL FOR SPECIAL SITUATIONS AND APPURTENENCES
- 20.04 CORROSION DESIGN FOR 16 INCHES AND LARGER DIP AND STEEL LINES
- 20.05 DUCTILE IRON PIPE
- 20.06 STEEL PIPE
- 20.07 ELECTRICAL GROUNDING AND HIGH VOLTAGE POWER

## **SECTION 20.00 CORROSION CONTROL FOR WATER PIPE**

### **20.01 Soil Resistivity Measurements**

Soil resistivity measurements shall be taken by an independent geotechnical laboratory and tested according to ASTM G187-05, *Standard Test Method for Measurement of Soil Resistivity Using the Two-Electrode Soil Box Method*. Results shall be submitted to Aurora Water Engineering for all projects requiring public water main extensions. Testing frequency shall not be less than one test for every 400 lineal feet of pipe (or fraction thereof). Testing shall be conducted at the approximate depth of pipe construction. These tests are required to accurately determine the appropriate pipe material type for each installation. Furthermore, additional corrosion protection shall be required for each specific project with pipe larger than 12 inches in diameter.

Soil samples shall be tested as follows:

#### **ALL SOIL SAMPLES SHALL BE TESTED IN A SATURATED CONDITION**

- a.) Pour or tamp material to be tested into soil box until flush with the top of box. The two brass potential pins should be temporarily removed to facilitate filling the box. Material should be tamped down until compacted to the same degree as soil at the test site.
- b.) Connect power supply and DC milliammeter so as to pass current between the two end terminals of the soil box.
- c.) Connect DC Electronic Voltmeter between the two brass potential pins which are located near the center of the soil box.
- d.) Using appropriate Milliammeter and Voltmeter ranges, measure the potential between the two brass pins with no current applied and again with measured current passed between the end terminals of the soil box.
- e.) Resistivity (in ohm-cm) = Change in potential (mv)/Current (ma)

### **20.02 Anode and Test Site Installation**

#### **20.02.1 Anodes**

Anodes shall be installed as specified for each particular installation and according to Standard Detail #219. Anodes shall be installed by the thermite weld process. The anode lead wire shall be placed in a way which does not strain the connection during backfilling and compaction. Anode leads shall be solid copper #12 American Wire Gauge (AWG) Thermoplastic High Heat-resistant Nylon-coated (THHN) or Thermoplastic High Water-resistant Nylon-coated (THWN) insulated wire 20" in length to allow sufficient slack and flexibility during

installation. Anodes shall be installed at a depth below the bottom of the pipe and preferably at least ten (10) feet away from the pipe. However in special situations may be placed a minimum of five (5) feet from the pipe as approved by the Engineer. Anodes shall be backfilled with native soil and soaked with a minimum of 5 gallons of water before backfilling.

### **20.02.2 Test Sites**

Test sites shall be installed as specified for each particular installation and according to Standard Detail #219. Test wires shall be #12 AWG solid THHN wire black in color. They shall be installed in the same manner as the anodes and bond wires. Sufficient slack shall be left in the wires to avoid any strain on the thermite weld. The test wires shall run to the surface and shall be installed in a 16 inch metal valve box with a metal lid stamped "CP Test", Tyler 6860 Series, 16" Valve Box or approved equal. Different color test wires shall be used for foreign lines, casings, etc. No splices or nicks in the wire or coating shall be allowed for either the anode lead wires or test wires. Two feet of slack shall be left in the test box at the surface. The test box shall be installed level with finished grades and each test site shall be permanently tagged in the box with a panduit marker.

### **20.02.3 Post Mounted Test Stations**

In areas out of the street and not paved, and not subject to high foot traffic, post mounted test stations shall be used in lieu of flush mounted test stations. Post mounted test stations shall be rectangular shaped cast aluminum test boxes a minimum of 4 inches by 8 inches by 2 inches deep. Post mounted test stations shall be provided with a minimum of five terminals mounted on a plastic or glass reinforced laminate terminal block. Terminals shall be stainless steel, brass or bronze. Test station boxes shall be mounted on a minimum 5 foot long threaded 1-1/4 inch rigid steel galvanized steel conduit and installed with a galvanized steel channel for support and protection. The galvanized steel C channel shall be a minimum of 6 feet long and 7 inches wide by 2 inches deep. The conduit shall be attached to the channel with U-bolts set a minimum of 1-1/2 feet apart. Test station shall be installed with the top of the test box approximately 2-1/2 feet to 3 feet above the surface. See Appendix B: Approved Materials List for acceptable post mounted test stations. Test sites outside the street area shall be marked by a blue marking post or with a City of Aurora Test Site sticker on the post.

### **20.02.4 Thermite Welding**

All wires installed by the thermite weld process shall be checked for proper installation. The weld material shall be contained on the wire and mold area without excessive runs. Each wire shall have a properly sized sleeve installed before welding and crimped to the wire with the

proper equipment. The wire shall be trimmed of insulation only to the point of allowing proper installation of the crimped sleeve. No nicks in the wire or coating shall be allowed. Thermite welds and molds shall be properly sized for the wire and sleeves. The pipe shall be cleaned to shiny metal before wire installation. All welds shall be tested by a sharp rap with a hammer to ensure the weld is secure. All welds shall be cleaned of slag, primed with spray primer, and covered with an approved capping product listed in Appendix B: Approved Materials List according to the manufacturer's recommendations. At the start of each project the contractor shall designate personnel demonstrating the ability to prepare and install bonds, anodes and test wires to the satisfaction of the Aurora Water Engineer. These personnel shall then be considered the competent persons on site to perform the above work and shall be the only people allowed to perform the installations. If they are unavailable, replacement personnel must demonstrate their competency before being allowed to perform the above installations.

Joints utilizing MegaLugs do not require joint bonding.

#### **20.02.5 Continuity Testing**

The Contractor shall be responsible for performing all continuity testing on bonded pipelines using methods approved by the City of Aurora corrosion personnel. Testing shall be performed by the Lineal Pipe Resistance Test Method by a qualified NACE Accredited Senior Corrosion Technologist, Cathodic Protection tester, Cathodic Protection Specialist, or Corrosion Specialist. A record of all tests shall be furnished to the City upon completion of the project. Any breaks in the continuity or broken test leads shall be repaired and all records furnished before a notice of final completion is issued. City of Aurora personnel shall observe the testing procedures to verify the results.

### **20.03 Corrosion Control for Special Situations and Appurtenances**

#### **20.03.1 Dissimilar Metals**

All tie-ins to dissimilar metals shall be dielectrically isolated by means of insulating flange kits, insulated dressers, etc. All isolating devices shall be properly installed per manufacturer recommendations and tested to ensure proper function. Testing shall consist of structure to soil readings on both sides of the insulating flange kit with both sides well grounded. The use of an insulator checker may be used, or application of sufficient direct current to one side of the device, to shift the potential approximately 100 millivolts without shifting the structure on the other side of the device. The Contractor shall not bury any dissimilar metallic couplings until visually inspected and the testing verified by Aurora Water personnel. Aurora Water personnel



may perform their own tests to confirm proper function of the device. A test site shall always be installed on either side of the device for future use in monitoring the device.

### **20.03.2 Restraining Rods and Bolts, Flanged Joints**

Restraining rods shall be wrapped in polyethylene sleeving for protection. Any restraining rod in contact with concrete such as thrust blocks, wall penetrations, etc. must be electrically isolated from the piping. Any restraining rods installed across an insulating device at dissimilar metals must be isolated as well. One piece sleeve and washers from an insulating flange kit shall be used to isolate the rods at the fittings. Flange-to-flange fittings shall utilize one-piece sleeve and washers with the washer placed on the unprotected flange.

### **20.03.3 Thrust Blocks and Flow Fill**

Concrete thrust blocks in contact with the pipe should be installed in such a manner as to not damage the pipe coating in anyway. All steel pipe coating shall be holiday tested upon installation and concrete shall not be dumped directly onto the pipe unless a rock shield product or equivalent is installed on the pipe. Ductile pipe shall be double polywrapped at the thrust block and a minimum of 2 feet on either side. Any areas where flow fill or ash fill is used shall have approved backfill placed a minimum of one foot over the pipe before pouring the flow fill or ash fill.

### **20.03.4 Bore Casings and Skids**

See Standard Detail #107 for bore casing thickness, diameters and approved models of casing skids. Bore casings under existing structures shall be uncoated bare steel. Casing pipe shall be polywrapped and anodes installed as needed where the casing is installed in an open cut for future projects. Steel piping installed in casings shall be tape coated according to the above Specifications for steel pipe coating.

Ductile pipe shall be polywrapped and the casing skids installed at locations per the Manufacturer's recommendation over the polywrap. Approved casing end seals shall be installed at each end of the casing. If for any reason casing fill material is required, clean dry sand shall be used.

### **20.03.5 Bridge Crossings**

Whenever a water main is suspended from a bridge deck, pipe shall be designed so no water from the bridge drips directly onto the pipe. The main shall also be completely insulated from the bridge deck support hangers as necessary.

### **20.03.6 Epoxy Coatings on Valves, Hydrants, and P.R.V.'s**

The interior of all valves, hydrants and P.R.V's shall be coated with a potable water epoxy as approved by N.S.F. and per AWWA Standard C550. In addition the exterior of all P.R.V's and check valves shall be epoxy coated except where P.R.V's are stainless steel.

### **20.03.7 Coatings in Vaults and Manholes**

All bare steel and ductile piping, connections, fittings and appurtenances in vaults or manholes shall be coated with cold applied petrolatum tape or petrolatum wax tape. Installation shall follow the AWWA recommendation C217-95 for buried steel pipelines but shall apply to ductile and steel piping.

## **20.04 Corrosion Design for 16 Inch and Larger DIP and Steel Lines**

Cathodic protection design for DIP and steel lines greater than 16 inches in diameter will be performed by Aurora Water Engineers upon first submittal of the civil drawing. Design will be delivered to the consultant prior to approval of the pipeline.

Design may be performed by a NACE International certified specialist or engineer with the express written approval of Aurora Water. All cathodic protection designs will be reviewed by an Aurora Water corrosion engineer.

## **20.05 Ductile Iron Pipe**

### **20.05.1 Tapping Procedures**

Any taps performed on these pipelines shall be done per Ductile Iron Pipe Research Association (DIPRA) and AWWA recommendations either by direct tapping or with approved saddles. All services shall be dielectrically insulated from the main. See Section 20.07 of these Specifications for additional information.

### **20.05.2 Polywrap**

All ductile pipe and fittings installed in the system shall be wrapped with 8 mil polywrap unless noted otherwise in the project drawings and specifications. Polywrap shall be installed according to DIPRA recommendations and AWWA C105/A21.5-93 method 'A'. Care shall be taken to insure all rips and tears are properly repaired. Care shall be taken to avoid damage to the polywrap during backfill and compaction.

### **20.05.3 Anode and Test Site Installation**

See Section 20.02

#### **20.05.4 Appurtenances**

Appurtenances such as valves, flanges, solid sleeves, etc. shall be double bonded according to the joint bonding procedures. If used, dressers shall have an additional bond wire across the dresser and across the gasket flange. All appurtenances shall be polywrapped per AWWA C105/A21.5-93 Section 4.3.3 and 4.3.4. Any buried flanged blow-off piping shall have heat shrink sleeves per Appendix B: Approved Materials List installed on the flanged portion to protect the bolts. All blow-off piping shall be polywrapped.

Dresser Couplings shall be used on steel pipe only. Solid sleeve couplings with spacer rings shall be used for all other pipe materials.

#### **20.05.5 Tie-ins to Dissimilar Metals**

See Section 20.03.1.

#### **20.05.6 Continuity Testing**

See Section 20.02.4.

### **20.06 Steel Pipe**

#### **20.06.1 Tapping Procedures**

All taps on steel pipelines shall be weld-on and performed by City of Aurora personnel. All taps shall be dielectrically insulated from the main.

#### **20.06.2 Coatings**

Steel pipe shall be coated with polyurethane per Appendix B: Approved products List. Joint connections shall be covered with heat shrink sleeves. Any flanged and/or bolted connections such as blow-offs shall be coated with wax or petrolatum tape per AWWA C217. Any coating repairs shall be compatible with the shop-applied coating system. For polyurethane coatings holidays and small repairs can be made with melt stick materials with proven adhesion and compatibility with polyurethane coatings (see Appendix B: Approved Materials List). Larger repairs can be made with single use kits of the same material as the coating or with spray applied coatings of the same material.

#### **20.06.3 Appurtenances**

Appurtenances such as valves, flanges, solid sleeves, etc. shall be double bonded similar to the

pipe joint bonding procedures. If used, dresser style couplings and solid sleeves shall have an additional bond wire across the dresser and across the gasket flange. All appurtenances on steel pipe shall be primed and coated in the same manner as the joints. Any buried flanged blow off piping shall have heat shrink sleeves installed on the flanged portion to protect the bolts. All blow-off piping shall be primed and coated if steel.

#### **20.06.4 Holiday Testing**

Holiday testing on coated steel pipe shall be performed both at the manufacturing facility and in the field just before pipe installation. Proper equipment and voltage levels recommended by the manufacturer for the specific coating and thickness being tested shall be used. The equipment shall be in proper working order, properly grounded, and all manufacturers recommendations followed. Testing shall be according to AWWA C209-95 Section 5.2.

### **20.07 Electrical Grounding and High Voltage Power**

#### **20.07.1 Electrical Grounding**

Any electrical grounding to the pipe such as at electric valve actuators, gauges, pumps, treatment plants, etc. must be isolated from the buried piping. Insulated flanges inside the building or vault structure shall be installed past the electrical grounding to isolate the pipe from the grounding. All wall penetrations shall be made utilizing sleeves and link seals or equivalent devices to ensure that the pipe is isolated from the concrete, rebar, and any electrical grounding hooked to the rebar. Test sites shall be installed directly outside the exit from the building or on both exits from vaults with electric controls for future use in monitoring the isolation devices. Properly sized and types of electrical isolation devices should be included in areas where the chance of electrical shock exists but isolation for cathodic protection reasons is desired.

#### **20.07.2 Foreign Cathodically Protected Line Crossings**

At any new pipeline crossing where the City of Aurora is crossing another cathodically protected structure or another entity is installing a structure across one of the City's existing bonded and/or cathodically protected pipelines, a minimum of three feet clearance between structures is required. If this is not possible, an insulating shield shall be placed between the structures. Shield type and distance shall be determined based on the site specific situation. Test leads with a minimum of #8 awg wire shall be brought up from each structure into one test box and carefully installed to a non conductive terminal block and clearly and permanently labeled with panduit marking devices. Each wire shall also be color coded and recorded to avoid any confusion between entities. If the other entity will not allow a test site attached to their

structure, two test leads, one on either side of the foreign structure, shall be installed and clearly marked showing they are only attached to the C.O.A. structure. All welds shall be cleaned of slag, primed with an approved spray primer, and covered with an approved capping product listed in Appendix B: Approved Materials List according to the manufacturer's recommendations.

### **20.07.3 High Voltage Buried and Overhead Power Lines**

Buried high power electric lines which cross City of Aurora water lines at a perpendicular angle shall have a minimum clearance of three feet between structures. If this is not possible, an insulating shield shall be placed between the structures. Shield type and distance shall be determined based on the specifics of the situation. Buried high power lines running parallel to City of Aurora water lines shall have a minimum of four feet of clearance both horizontally and vertically from the water line.

A continuously bonded water line running parallel to buried or overhead high power lines shall require test sites to be installed. Anodes may have to be installed to monitor and possibly provide for drain points for induced alternating current build up on the water line. This must be addressed on a specific case by case basis at installation. Smaller DIP lines may have to be bonded and anodes installed depending on the specific situation or PVC pipe may be required in its place.

**THIS PAGE IS INTENTIONALLY BLANK**

## **SECTION 21.00 SANITARY SEWER PIPE INSTALLATION**

- 21.01 GENERAL
- 21.02 PROGRESSION OF WORK
- 21.03 LINE AND GRADE
- 21.04 CRADLES AND ENCASEMENTS
- 21.05 TEES, WYES, AND RISERS
- 21.06 CLEANING THE LINE
- 21.07 TESTING AND INSPECTION

## **SECTION 21.00 SANITARY SEWER PIPE INSTALLATION**

### **21.01 General**

Unless otherwise specified, all pipe handling, laying and jointing shall be based upon manufacturers' recommended practice for installation of each specified type of pipe. Provisions of this section shall supersede and augment those recommendations.

### **21.02 Progression of Work**

The laying of pipe shall commence at the lowest point and proceed up grade so the pipe is laid with the bell ends facing upstream and at the correct grade and alignment. A plug shall be placed and maintained in watertight condition where a new line is connected to an existing sewer main during construction. The pipe shall be placed so the specified bedding provides a solid, uniform bearing surface for the full length of the barrel. Bell holes shall be provided at all joints. Equipment used in handling and jointing the pipe shall have adequate capacity to handle the pipe smoothly and ensure proper closure of joints.

All pipe shall be carefully constructed so when joined they will form a conduit with a smooth, uniform invert. The pipe shall be laid accurately to the grade and alignment specified on the drawings. Blocking or wedging of the pipe to achieve proper positioning and grade shall not be permitted, except where required for proper construction cradles or encasements.

Clean-outs shall not be allowed as a substitute for manholes on sanitary sewer mains.

### **21.03 Line and Grade**

All piping shall be constructed to the lines and to the grades and elevations shown on the approved drawings. Laser devices or grade stakes shall be used to maintain proper grades. Grade stakes at a minimum spacing of twenty-five feet (25') shall be used for grades less than 0.40%.

### **21.04 Cradles and Encasements**

See Section 11.08 of these Specifications.

### **21.05 Tees, Wyes, and Risers**

The Contractor shall place tees, tee-wyes, stubs, and risers where required by the approved



construction plans. Wyes shall be used only for service to lots at the back of a cul-de-sac. Tees shall be angled upwards so the upper invert of the 45 degree bend connected to the fitting shall have an elevation equal to or higher than the inside crown of the sewer main. Riser connections may be installed where the elevation of the top of the branch is more than twelve feet (12') below finished ground. Watertight plugs shall be installed and maintained in each branch pipe or stub until the service connection is made. Tee and riser locations shall be marked with steel 'T' posts or wooden 4X4's. See Section 23.00 for details on service stub-ins and house service connections. As-built measurements shall be made to the nearest manhole before backfilling.

## **21.06 Cleaning the Line**

When all of the pipes have been installed, the line and manholes shall be cleaned and be free of sand, dirt and debris. If the line must be flushed, it shall be done by use of a high-pressure jet or sewer balling method. Care shall be taken to ensure no sand, dirt and/or debris enters the existing sanitary system during the flushing operation. Should the Contractor allow deleterious material to enter and damage the existing system, costs of removing sand and dirt from the system, and any fines according to City Code will be at the Contractor's expense.

Removal of any material or debris entering the sanitary sewer main as a result of construction activities causing a disruption of flow or stoppage shall be the responsibility of the Contractor. This shall include cleaning and restoration of all affected residences and businesses.

## **21.07 Testing and Inspection**

Sanitary sewer lines shall pass the following tests before initial acceptance as specified.

### **21.07.1 Water Tightness**

A test for water tightness of the sewer line and its appurtenances may be required under the supervision of the authorized representative of the Engineer. The sewer pipe, all connections, and all appurtenances shall not leak under normal external ground water pressure more than 50 gallons per inch of inside diameter per mile of sewer per 24 hours. Leakage shall be measured between consecutive manholes, and shall not exceed the limit of infiltration between any two manholes. Sections of pipe having infiltration rates above the maximum shall be repaired or replaced at the Contractor's expense. The system must not leak with a 6 foot head of internal pressure. The loss of water from any portion of the completed sewage system shall be investigated and immediate measures taken to correct the loss.

Force Mains shall be hydraulically tested for water tightness. The main shall be subject to a test pressure no less than the operating pressure for the system. Operating pressure shall include the pumping head plus 100 psi surge pressure. This information shall be provided on the approved project drawings.

### **21.07.2 Visual Inspection**

All sanitary sewer line construction will be visually inspected for conformance to approved civil drawings by the Inspector. This inspection will include, but not be limited to, bedding, alignment, elevation, infiltration, misalignment, broken pipes and other deficiencies. Defects noted during inspection shall be repaired to the satisfaction of the Engineer.

### **21.07.3 Televised Inspection**

The contractor is responsible for scheduling and conducting Closed Circuit Television (CCTV) inspection of the pipe after construction. CCTV inspection must be performed with water flowing through the pipe, or with camera equipped with an inclinometer. CCTV records shall be provided to Aurora Water Wastewater Division on DVD. Any defects discovered during review of the televised inspection will be supplied to the contractor in writing and corrected to the satisfaction of the Engineer. If required, the Contractor shall schedule reinspection via CCTV of the completed main prior to the issuance of the Notice of Initial Acceptance.

Initial Acceptance or notice of discrepancies will be issued within 72 business hours of receipt of CCTV record by the Wastewater Division.

### **21.07.4 Repair Procedure:**

Repair Procedure: Joints allowing infiltration or exfiltration shall be replaced until the pipe is deemed watertight. Pipes with structural damage shall not be collared or grouted, but shall be replaced. The Contractor shall notify the Inspector 24 hours in advance of any repair work to the completed main.

## **SECTION 22.00 POLYVINYL CHLORIDE (PVC) GRAVITY SEWER LINE**

- 22.01 GENERAL
- 22.02 DIAMETER OF PIPE
- 22.03 WALL THICKNESS DESIGN OF PIPE
- 22.04 FITTINGS AND SPECIALS
- 22.05 JOINTS
- 22.06 PIPE LENGTHS
- 22.07 MARKINGS ON PIPE

## **SECTION 22.00 POLYVINYL CHLORIDE (PVC) GRAVITY SEWER PIPE**

### **22.01 General**

All materials, manufacturing operations, testing and inspection of PVC Sewer Pipe shall be in conformity with the requirements of ASTM D3034-SDR35 for 4 inch to 15 inch PVC. Requirements shall be in conformity with ASTM F679 for 18 inch to 27 inch PVC. PVC pipe greater than 27 inch in diameter shall be considered on a case by case basis. Individual applications shall be reviewed and approved by Aurora Water specifically for the proposed application. Profile wall PVC shall be in conformity with the requirements of ASTM F794.

### **22.02 Diameter of Pipe**

The diameter indicated on the approved construction drawings shall mean the nominal inside diameter of the pipe.

### **22.03 Wall Thickness Design of Pipe**

The standard dimension ratio of the diameter to the wall thickness shall be ASTM D3034-SDR35.

### **22.04 Fittings and Specials**

All fittings and specials shall conform to the requirements set forth in ASTM D3034-SDR35 or ASTM F679 and shall have the same structural properties and the same bell and/or spigot configurations as an adjoining pipe.

### **22.05 Joints**

All PVC joints shall be of bell and spigot type. The bell shall consist of an integral wall section. The rubber ring shall be in accordance with ASTM F477. The joint shall meet the requirements of ASTM D3212. Spigot ends shall be smooth and free of burrs prior to making the joint. A lubricant, as specified by the pipe manufacturer, shall be applied to the spigot end to prevent damage to the ring and aid in making a tight joint.

### **22.06 Pipe Lengths**

Pipe sections shall be furnished in lengths no shorter than 12½ feet except service tees and closure pieces. The maximum pipe length shall be 20 feet.

## **22.07 Markings on Pipe**

PVC Sewer Pipe shall be any color other than blue or purple to distinguish the sewer pipe from water conduits except when AWWA C900 PVC is required by the Engineer. Each pipe shall be marked by the manufacturer with the appropriate ASTM designation. Any pipe or fittings not properly marked shall be rejected and removed from the job site.

**THIS PAGE IS INTENTIONALLY BLANK**

## **SECTION 23.00 SANITARY SEWER SERVICE LINE CONSTRUCTION**

- 23.01 GENERAL
- 23.02 MATERIALS
- 23.03 LOCATION AND ALIGNMENT OF SERVICE
- 23.04 SERVICE LINE INSTALLATIONS
- 23.05 TAPPING THE MAIN
- 23.06 CLEAN OUTS
- 23.07 SERVICE STUB-IN TO PROPERTY LINE
- 23.08 SIDEWALK OR CURB CROSSING
- 23.09 TRENCH BACKFILLING
- 23.10 INSPECTION
- 23.11 MAINTENANCE OF TRAFFIC
- 23.12 WARRANTY OF WORK
- 23.13 DISCONTINUATION OF SEWER SERVICE

## **SECTION 23.00 SANITARY SEWER SERVICE LINE CONSTRUCTION**

### **23.01 General**

All sanitary sewer service lines which connect to the City of Aurora sanitary sewer system shall adhere to this section and Section 22.00 of these Specifications.

### **23.02 Materials**

#### **23.02.1 PVC Pipe**

PVC pipe used for sanitary sewer services shall meet or exceed ASTM D3034-SDR35. All joints shall be watertight. Fittings, saddles, bends, etc. shall be PVC type or other materials as approved by the Engineer. Glued joints shall not be allowed beyond 5 feet from the foundation.

Down gradient from this point only gasket joints shall be used in the service line. Pressure rated PVC pipe can be used up to, but no more than, 5 feet outside of the foundation wall for connection to the SDR-35 pipe.

All pipes shall be subject to inspection upon delivery to the job site. Plastic joint material damaged in any way shall be cause for rejection of the pipe.

#### **23.02.2 Ductile Iron Pipe:**

Ductile iron pipe shall be installed where required on the plans and as required by the Inspector. The materials shall conform to Section 12.00 of these Specifications. All joints shall be watertight.

### **23.03 Location and Alignment of Service**

Sanitary sewer service lines shall be constructed on the shortest and straightest route possible. At no time shall service lines be any closer than 5 feet to the side property line, and no service line may be constructed through or in front of any adjoining property. Typically, the service line shall be located 5 feet toward the low side of the lot from the centerline of the lot and at least 10 feet horizontally from the water service line.

### **23.04 Service Line Installations**

In general, all installation work shall conform to applicable portions of ASTM C12 and to the pipe manufacturer's installation instructions.

Pipe shall be laid according to Standard Detail #300. Sewer and water service lines must be a



minimum of 10 feet apart horizontally or 8 feet apart horizontally if the water service is installed at least 2 feet above the sewer service for the entire length of the service laterals. Concrete encasement of the sewer line shall be required if minimum clearances cannot be maintained. The pipe shall be protected from damage at all times. The grooves shall be cleaned to be free from all foreign materials before assembling the joint. The pipe shall be laid with the spigot ends pointing in the direction of flow. All joints shall be watertight. The joining of dissimilar materials like PVC pipe to VCP pipe shall be done by means of an adapter specifically designed for the connection encased in concrete or other method approved by Aurora Water Engineering. Trenches shall be kept free of water during laying and jointing. The minimum grade for a 4 inch line shall be 2.00% or ¼ inch per foot.

The Inspector shall have the authority to require that the exact grade of the line be determined before backfilling the trench.

## **23.05 Tapping the Main**

### **23.05.1 General**

Whenever the diameter of the service line is equal to or greater than 75% of *an existing* sewer main, a manhole shall be installed in place of a saddle tee. Direct service line taps may be made on existing mains smaller than 24 inches in diameter. The Inspector shall inspect the main, the saddle and the service line to the building at every tap or tee before backfilling.

Twenty-four hour notice is required prior to inspection by Aurora Water. In the event the tap and service line are covered before it is inspected, it shall be re-excavated by the Contractor, and cleared allowing for visual inspection of the tap and main. If the sewer main is cracked or broken during the process of locating or tapping, it shall be repaired immediately by replacing the broken section at the Contractor's expense. Wyes shall be used only for service to lots at the back of a cul-de-sac and connected to a stub-out upstream of a manhole.

A manhole shall be installed instead of a saddle tee when a 6 inch connection is to be made to an existing 8 inch main, or any time the service line is equal to or greater than three-quarters the diameter of the main. Service lines shall not empty directly into a manhole unless the manhole has been specifically and exclusively constructed for the service line. Service lines 4 inches in diameter are not allowed to discharge into a public manhole.

### **23.05.2 V.C.P. Mains**

Where tees have not been installed in the main sewer, the main shall be tapped by machine drilling a hole the size to fit the saddle for the service line. The Inspector shall approve the drilling machine and method of drilling.

### **23.05.3 PVC Mains**

Where PVC tees have not been installed in the main, a PVC saddle tee shall be installed according to the manufacturer's recommendations and these Specifications. A keyhole, saber saw or shell cutter shall be used to cut a round hole in the PVC main. The tapping saddle or connection shall not protrude into the main. All edges shall be filed smooth. The surfaces to be jointed shall be wiped clean, etched and the primer applied. With primer still wet, apply the approved cement and install the saddle. The saddle shall be drawn down with stainless steel metal straps or other approved means.

### **23.05.4 Ductile Iron or Cast Iron Mains**

Where cast iron tees have not been installed in the sewer main, the main shall be tapped by machine drilling a hole of a size which shall fit a saddle for the service line. The drilling machine and method of drilling and the saddle shall be approved by the Inspector. The saddle shall be sealed when attached to the main and held in place with metal straps or other approved means.

### **23.05.5 Concrete Mains**

Concrete mains shall not be tapped. A manhole according to these Specifications shall be installed to provide sewer service.

### **23.05.6 Re-lined Mains**

Where a service line taps into an existing re-lined main, the reliner shall be exposed around the full circumference of the main for one and one half times the width of the saddle tee. A keyhole, saber saw or shell cutter shall be used to cut a round hole in the reliner. The tapping saddle or connection shall not protrude into the main. All edges shall be filed smooth. The surfaces to be jointed shall be wiped clean, etched and the primer applied. With primer still wet, apply the approved cement and install the saddle. The saddle shall be drawn down with stainless steel metal straps or other approved means. The saddle and sewer main shall be encased in concrete.

### **23.06 Clean Outs**

Clean outs shall be constructed according to Standard Detail #301. Clean outs shall be constructed so no surface load shall be transferred to the main, wye, 1/8 bend, or riser pipe. The area around a clean out shall be graded so water runs away from the clean out. Clean outs are required at a maximum interval of 100 feet or at changes in grade. Services may have up to two 1/8 bends (either horizontal or vertical) without clean outs. In no case shall a maximum total deflection exceeding 90 degrees be installed without clean outs.

### **23.07 Service Stub-In to Property Line**

Service stub-ins shall be extended at least to the property line and be plugged with a PVC compression stop. The end shall be pressure capped and marked at the surface with a 4" x 4" wood or steel "T" post.

Exact locations of the service line taps from a manhole shall be noted during CCTV inspection by the Contractor as necessary.

### **23.08 Sidewalk or Curb Crossing**

In no instance shall trenches extend beneath an existing sidewalk or curb. The pipe must be bored, jacked, or tunneled through the earth under the curb or sidewalk, or the sidewalk removed and replaced.

### **23.09 Trench Backfilling**

Backfilling shall conform to Section 9.00 of these Specifications. The City of Aurora Material Testing Laboratory personnel must approve the compaction test on the service trench within the street right-of-way prior to patching the street.

### **23.10 Inspection**

Aurora Water Engineering Inspectors will inspect all work from the sanitary sewer main to the building. This includes new services as well as service repairs. The Inspector has the authority to halt construction when, in their opinion, these Specifications or proper construction practices are not being followed. Whenever any portion of these Specifications is violated, the Inspector may order further construction to cease until all deficiencies are corrected. No pipe fittings or connections shall be covered until approved by the Inspector. Inspections can be scheduled by

calling the Inspections Line at 303-739-7385 at least 24 hours before the time when inspection is needed.

### **23.11 Maintenance of Traffic**

Interference with traffic shall be avoided at all times. Adequate barricades, signs and warning devices shall be placed and maintained until the site is restored to its original condition. Refer to the Public Works Roadway Design and Construction Specifications for further information.

### **23.12 Warranty of Work**

The Owner/Developer shall warrant all work to be free from defects in workmanship or materials for a period of one year from the date of initial acceptance. The Owner/Developer shall be responsible for any settlement or deterioration and shall maintain the surface over trenches in approved condition throughout the warranty period.

### **23.13 Discontinuation of Sewer Service**

Whenever a sewer service will be discontinued for a period longer than 6 months, the service line shall be uncovered at the sewer main and the service connection removed and sealed with a watertight plug. An Inspector will inspect the disconnection prior backfilling the hole. Backfilling shall conform to Section 23.09 of these Specifications. Should the sewer service be scheduled to be returned to service within 6 months, instead of disconnection at the main, the service line shall be disconnected by removing a one foot section of the service line directly inside the property line and the end sealed with a watertight plug. The Inspector will inspect the disconnection before backfilling. Aurora Water reserves the right to require disconnections of abandoned sanitary sewer taps at the main if the existing service or tap is in unsatisfactory condition. Existing service laterals which are damaged, leaking or in any other condition which may lead to future repair of the main shall be deemed unsatisfactory.

## **SECTION 24.00 UNDERDRAIN PIPE**

- 24.01 GENERAL
- 24.02 PVC PIPE
- 24.03 HDPE PIPE
- 24.04 BEDDING
- 24.05 ALIGNMENT
- 24.06 UNDERDRAIN CLEAN OUTS

## **SECTION 24.00 UNDERDRAIN PIPE**

### **24.01 General**

Underdrain pipe shall be polyvinyl chloride (PVC) or High Density Polyethylene (HDPE) and provided with joints which prevent any shifting or misalignment of the line, or joints which in the opinion of the Engineer will allow adequate infiltration or exfiltration. Main underdrain lines shall be 6 inches in diameter. Lateral underdrains must have a minimum diameter of 4 inches. The underdrain system shall in no case be constructed with sealed joints.

The City of Aurora will NOT maintain underdrains. These systems shall remain private in perpetuity. When underdrain pipe is laid in a public ROW or easement, Water Engineering Inspections will inspect those portions of the underdrain system.

### **24.02 PVC Pipe**

All nonperforated PVC pipe shall conform to ASTM 3034-SDR 35. Perforated PVC shall have perforations located in the lower quadrant. PVC underdrain shall be wrapped per geotechnical engineers recommendations. The pipe shall be installed without gaskets and in full compliance with ASTM D2321. The system shall not be watertight.

### **24.03 HDPE Pipe**

All non perforated pipe shall conform to AASHTO M252 Type 'S'. All perforated HDPE Pipe shall conform to AASHTO M252 Type 'SP'. Color of pipe shall be black. Material shall be resistant to ultraviolet rays. The system shall not be watertight.

### **24.04 Bedding**

Bedding for underdrain pipe in trenches shall meet the general requirements of Class B alternate bedding. If the underdrain is to be installed with a sanitary sewer main, the trench shall be sub-excavated to a depth of 1 foot below the flowline of the sanitary sewer main per Standard Detail #100. The underdrain pipe shall be placed on the bottom of the trench approximately 6 inches from the trench sidewall, and the trench backfilled with tamped granular bedding material to 1 foot above the main. In the event unstable trench conditions are encountered which will not support the pipe, the trench shall be further sub-excavated and backfilled with 1½ inches of uniformly graded washed rock to within 6 inches of the underdrain pipe flow line and the remainder filled with granular bedding material. The underdrain pipe shall not be placed directly

on top of the uniformly graded rock material. Crushed concrete is prohibited as a bedding material for underdrains.

### **24.05 Alignment**

The grade of the underdrain pipe shall be parallel to and 1 foot below the flow line of the sanitary sewer main. The underdrain shall outfall into a storm sewer or drainage course. At no time shall an underdrain be unable to drain. The underdrain connection shall be properly grouted into a storm sewer pipe or inlet. When emptying into a water course, the outlet shall be protected with a CDOT approved outlet structure or headwall.

### **24.06 Underdrain Clean Outs**

Clean outs shall in no case be installed inside of a sanitary sewer manhole, but are allowed to be installed on the outside of a manhole. Clean outs shall not be the responsibility of the City of Aurora to maintain and shall be constructed in accordance with Standard Detail #302.

Clean outs shall be constructed so no surface load will be transferred to the main, wye, bend, or riser pipe and shall be left below the pavement surface.

**THIS PAGE IS INTENTIONALLY BLANK**



## **SECTION 25.00 STORM SEWER PIPE INSTALLATION**

- 25.01 GENERAL
- 25.02 APPROVED PIPE MATERIALS
- 25.03 PIPE SIZE
- 25.04 EXCAVATION
- 25.05 BEDDING
- 25.06 INSTALLATION
- 25.07 BACKFILL AND COMPACTION

## **SECTION 25.00 STORM SEWER PIPE INSTALLATION**

### **25.01 General**

Designers shall use Sections 27.00 to 30.00 to select pipe materials to be used for storm sewer within the City of Aurora. These Specifications were prepared in accordance with the Urban Drainage and Flood Control District, “Storm Sewer Pipe Material Technical Memorandum 3<sup>rd</sup> Edition”, dated July 13, 2010, referred to as the “Report.” When, in the opinion of the Engineer, the proposed pipe material for any installation does not conform to the recommendations of the Report, the City shall reserve the right to require a specific pipe material and bedding class. Only those pipeline materials described in the following sections shall be approved for storm sewer installations. All pipe materials to be incorporated in the construction of storm sewers shall conform to the requirements specified herein or as modified elsewhere in these Specifications. The following information shall be submitted as required with the design of a storm sewer system.

- Soils Characteristics
  - Moisture content
  - Compactability
  - Classification
  - Stability
  - Industrial waste products (Hydrocarbons)
  - Organic contaminants
  - pH
  - Sulphate (total as SO<sub>3</sub> )
  - Subsidence
  - Soil resistivity
- Design Depth of Cover
- Groundwater Level
- Bedding Class and Class of Pipe

Resistivity measurements shall be performed according to Section 20.01 of these Specifications.

## **25.02 Approved Pipe Materials**

The following storm sewer pipe materials are approved for use within the City of Aurora:

- Reinforced Concrete Pipe (RCP)
- Reinforced Concrete Box Culvert Pipe (RCBC)
- Aluminized Steel Type 2 Pipe (ASP) (for private systems only)
- Polyvinyl Chloride Pipe (PVC)
- High Density Polyethylene Pipe (HDPE)
- Profile Wall Pipe (PE, HDPE, and PVC)

Pipe material selection charts are provided in subsequent sections for each pipe material. These charts present conditions the designer should follow in the selection of an appropriate pipe material. The Report shall be referenced for specific standards if the conditions vary from what is presented in the charts.

Storm sewers placed in arterial roadways within the C.O.A. Right-of-Way shall be reinforced concrete pipe, Class III or higher. Other alternate pipe materials shall not be considered for use in arterial roadways.

Ductile Iron Pipe (DIP) can be used in private systems where traffic loading conditions dictate.

## **25.03 Pipe Size**

Storm sewer pipe to be maintained by City of Aurora shall be sized accordingly as shown on the project drawings but shall in no case be less than 18 inches in diameter. Arched and elliptical pipe shall only be allowed when conditions prevent the use of circular pipe. Profile wall pipe shall only be allowed in diameters 18-inches and larger.

## **25.04 Excavation**

Excavation of the pipe shall conform to Section 8.00 of these Specifications.

## **25.05 Bedding**

Storm sewer pipe placed within the City of Aurora shall be bedded according to Section 9.00 of these Specifications. Specific bedding classes for each installation shall be provided on the civil

construction plans.

No less than Class B Alternative Compacted Granular Bedding Class shall be used for ASP, PVC and HDPE storm sewer. Bedding class for RCP storm sewer installation shall be specified on the project drawings.

## **25.06 Installation**

The Contractor shall use equipment, methods and materials which will ensure the pipe is installed according to the approved project drawings. Alignment and grade shall be kept to within  $\pm 1$  inch per 100 feet of the line and grade as indicated on the drawings.

Pipe shall not be placed on blocks unless the pipe is to be encased in concrete.

Horizontal and vertical alignment deflection shall be accomplished at manholes only. Curvilinear storm sewer lines shall not be allowed. The Contractor shall begin placement of pipelines at the downstream end and proceed laying pipe with the spigot or tongue ends in direction of flow.

Every reasonable effort shall be made by the Contractor to preclude foreign material from entering the pipeline during and after installation. This shall be accomplished with snug-fitting closures placed at the end of each working day and appropriate “Best Management Practices” to protect the newly installed storm system from sediment deposits as necessary. The Contractor shall remove dirt or debris from the pipeline prior to additional installation and final acceptance by the City.

## **25.07 Backfill and Compaction**

Backfill shall be defined as the area above the pipe bedding section. The trench shall be backfilled and compacted according to Section 9.00 of these Specifications.

After backfill and compaction of the trench is completed, the Contractor shall schedule an inspection of the completed pipeline and appurtenances for Initial Acceptance. The Contractor will be notified of any deficiencies and shall be required to correct the deficient items prior to Initial Acceptance.

Deflection testing may be required as directed by the Engineer. Flexible pipe 48 inch diameter or less shall be tested with a “Go/NoGo” deflection test gage, which shall be pulled through the

pipe. The horizontal diameter shall not differ from the design diameter by more than 5 percent. Pipe exceeding the maximum allowable deflection shall be removed and replaced by the Contractor. The equipment and labor for deflection test procedures shall be supplied by the installation Contractor.

All required testing and inspection shall be performed prior to the issuance of a paving permit. Furthermore, compaction tests shall be submitted to the City of Aurora Materials Testing Laboratory for review and approval prior to the issuance of a paving permit.

**THIS PAGE IS INTENTIONALLY BLANK**

**SECTION 26.00 REINFORCED CONCRETE (RCP) STORM SEWER  
PIPE**

- 26.01 GENERAL
- 26.02 CEMENT
- 26.03 FITTING AND SPECIALS
- 26.04 LIFTING HOLES
- 26.05 ACCEPTANCE OF PIPE FOR CONSTRUCTION
- 26.06 MARKING
- 26.07 JOINTS
- 26.08 PIPE SELECTION CHART

## **SECTION 26.00 REINFORCED CONCRETE (RCP) STORM SEWER PIPE**

### **26.01 General**

Only those pipeline materials described in this section will be approved for storm sewer installations. All pipe materials to be incorporated in the construction of storm sewers will conform to the requirements specified herein or as modified elsewhere in these specifications. All concrete pipe will meet the requirements of AASHTO M170, AASHTO M242, ASTM C76, ASTM C655 or ASTM C361. Infiltration will be limited to 200 gallons per inch of diameter per mile per day when rubber gasket joints are required. Storm Sewer pipe placed within C.O.A. arterial roadways shall be RCP Class III or higher. RCBC is allowed only on a case-by-case basis with prior approval from City.

### **26.02 Cement**

Unless otherwise required by the Engineer, Type II Portland Cement complying with the requirements of ASTM Designation C150 will be acceptable in the manufacture of concrete pipe.

### **26.03 Fitting and Specials**

Details of all fittings and specials will be submitted to the Engineer for approval. Fittings and specials will be made up of pipe segments having the same structural qualities as the adjoining pipe and will be as shown on the drawings. Laying diagrams will be approved by the Engineer before construction.

### **26.04 Lifting Holes**

Lifting holes will be allowed and will be grouted closed before final inspection and initial acceptance of completed pipeline. Holes will be placed at the top of the pipe. Only two lifting holes will be allowed per pipe segment.

### **26.05 Acceptance of Pipe for Construction**

In addition to deficiencies covered by the applicable ASTM Specifications, concrete pipe having any of the following visual defects will not be accepted:

- Porous areas on either the inside or the outside surface of a pipe section having an area of more than 10 square inches and a depth of more than ½ inch.
- Pipe patched or repaired without approval of the Engineer.



- Exposure of the reinforcement.
- Pipe damaged during shipment or construction.

Acceptance of the pipe will not relieve the Contractor of full responsibility for any defects in material or workmanship of the completed pipeline.

## **26.06 Marking**

The following will be clearly marked on the interior of the pipe wall:

- ASTM Specification
- Class and size
- Date of manufacture
- Name or Trade-Mark of Manufacturer

## **26.07 Joints**

The joint design for concrete pipe shall be bell and spigot or tongue and groove. Where rubber gaskets are required or specified, the bell or tongue shall be of confined gasket or single offset spigot configuration. The joint assemblies shall be accurately formed so when each pipe section is forced together in the trench the assembled pipe shall form a continuous watertight conduit with smooth and uniform interior surface. If a gasketed joint is used, the gasket shall be the sole element of the joint providing water tightness

The jointing material used for concrete pipe storm sewer installations thirty six-inch (36") diameter and greater shall be a rubber gasketed joint. For storm sewers less than thirty six-inch (36") diameter the jointing material may be either a rubber gasket or a flexible plastic sealing compound, unless otherwise specified.

All joints and jointing material shall conform to the following minimum requirements.

### **26.07.1 Rubber Gasketed Joints**

Rubber gasket joints for tongue and groove or bell and spigot pipe using a confined gasket joint shall consist of an O-ring rubber gasket or other approved gasket configuration and shall conform to the requirements of the appropriate ASTM Specification of the pipe designated. Rubber gasket joints for tongue and groove or bell and spigot pipe using a single offset joint shall consist of a circular or non-circular rubber gasket or other approved gasket configuration and shall conform to the requirements of the appropriate ASTM Specification of the pipe. Gaskets may be either natural rubber or neoprene conforming to ASTM C443.

### **26.07.2 Flexible Plastic Joint Sealing Compound**

Preformed plastic gaskets conforming to the minimum requirements set forth above may be used as a joint sealant for storm sewer installations in lieu of rubber gaskets providing the flexible plastic gasket is in conformance with ASTM C990 and the plastic sealing compound is packaged in extruded preformed rope-like shape of proper size to completely fill the joint when fully compressed. The material shall be protected in a suitable, removable, two-piece wrapper so no wrapper may be removed as the compound is applied to the joint surface without disturbing the other wrapper, which remains attached to the compound for protection. The sealing compound shall be impermeable to water, have immediate bonding strength to the primed concrete surface and shall maintain permanent plasticity, and resistance to water, acids, and alkalis.

### **26.07.3 Mortared Joints**

Mortared joints shall only be used in special circumstances and only where specifically authorized by the Engineer.

# 26.08 Pipe Selection Chart

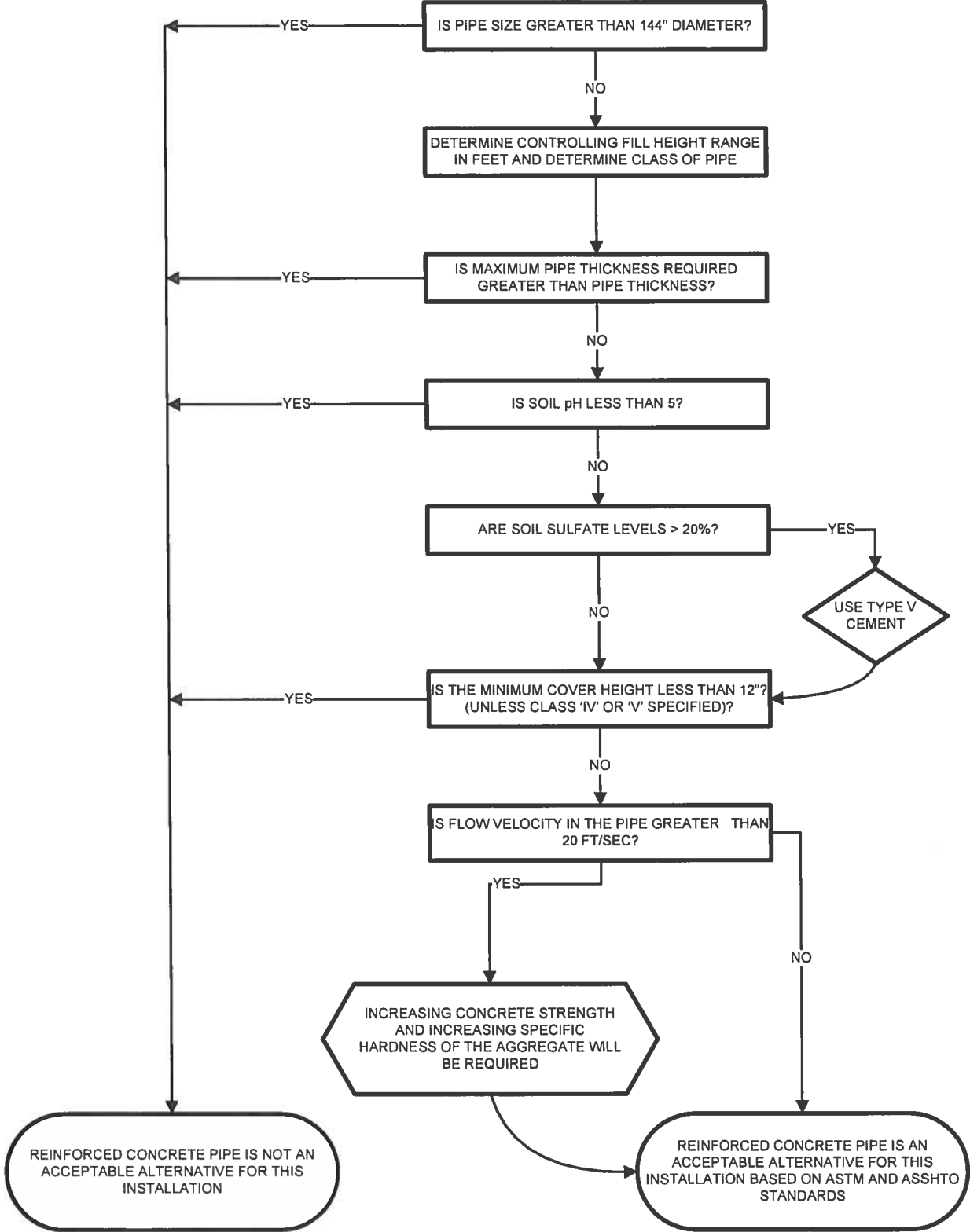

**THIS PAGE IS INTENTIONALLY BLANK**

## **SECTION 27.00 ALUMINIZED STEEL (ASP) STORM SEWER PIPE**

- 27.01 GENERAL
- 27.02 WALL THICKNESS AND GAGE
- 27.03 PIPE SEAMS AND ENDS
- 27.04 FITTINGS AND SPECIALS
- 27.05 PROTECTIVE COATINGS
- 27.06 COUPLING BANDS
- 27.07 PIPE SELECTION CHART

## **SECTION 27.00 ALUMINIZED STEEL (ASP) STORM SEWER PIPE**

### **27.01 General**

Only those pipeline materials described in this section shall be approved for storm sewer installations. ASP Pipe can only be used on a case-by-case basis in private storm sewer systems with City review and approval.

Except as modified herein, all materials, manufacturing operations, testing, inspection and marking of spiral-ribbed, Aluminized Steel Type 2 pipe and pipe arch shall conform to the requirements of AASHTO M36, M274 and ASTM A760, A796, A798 latest revisions.

### **27.02 Wall Thickness and Gage**

Minimum thicknesses and fill heights for spiral-ribbed, ASP shall be as follows:

Pipe Size (Inches)	Thickness (Ga.)	Minimum Cover (Feet)
18-48	.064" (16 ga.)	1.0
54-60	.079" (14 ga.)	1.5
66-72	.109" (12 ga.)	1.5
Over 72	Design	2.0

THIS MATERIAL IS NOT APPROVED FOR USE WITHIN ARTERIAL ROADWAYS.

### **27.03 Pipe Seams and Ends**

Pipe ends shall be fabricated with helical corrugations having a continuous lock seam extending from end to end of each length of pipe. Each end of each length of pipe shall be re-rolled to a minimum of 3 annular corrugations.

### **27.04 Fittings and Specials**

Details of all fittings and specials shall be according to ASTM 998 or as shown on the approved project drawings. Fittings and specials shall be made of the same material and shall have the same structural qualities as the adjoining pipe. Under no conditions shall the wall thickness be less than the adjoining pipe.

All factory made tees shall be subject to City review prior to acceptance on a case-by-case basis.

Such tees are prohibited where they may be subject to wheel loads.

### **27.05 Protective Coatings**

All metal sheets for pipe shall be formed from Aluminum Steel Type 2 sheet conforming to AASHTO M274.

### **27.06 Coupling Bands**

Aluminized Type 2 steel pipe used within the City of Aurora shall utilize coupling bands manufactured according to AASHTO M36. Coupling bands shall be no less than 10½ inches wide and shall be made from aluminized steel of the same thickness as the pipe.

Coupling bands shall incorporate the use of O-ring gaskets meeting or exceeding the requirements of AASHTO M198 and shall be placed on both sides of the joint. Each coupling band is required to have bar, bolt, and strap connector assemblies per lap. Hardware for coupling bands shall conform to AASHTO M36.

## 27.07 Pipe Selection Chart

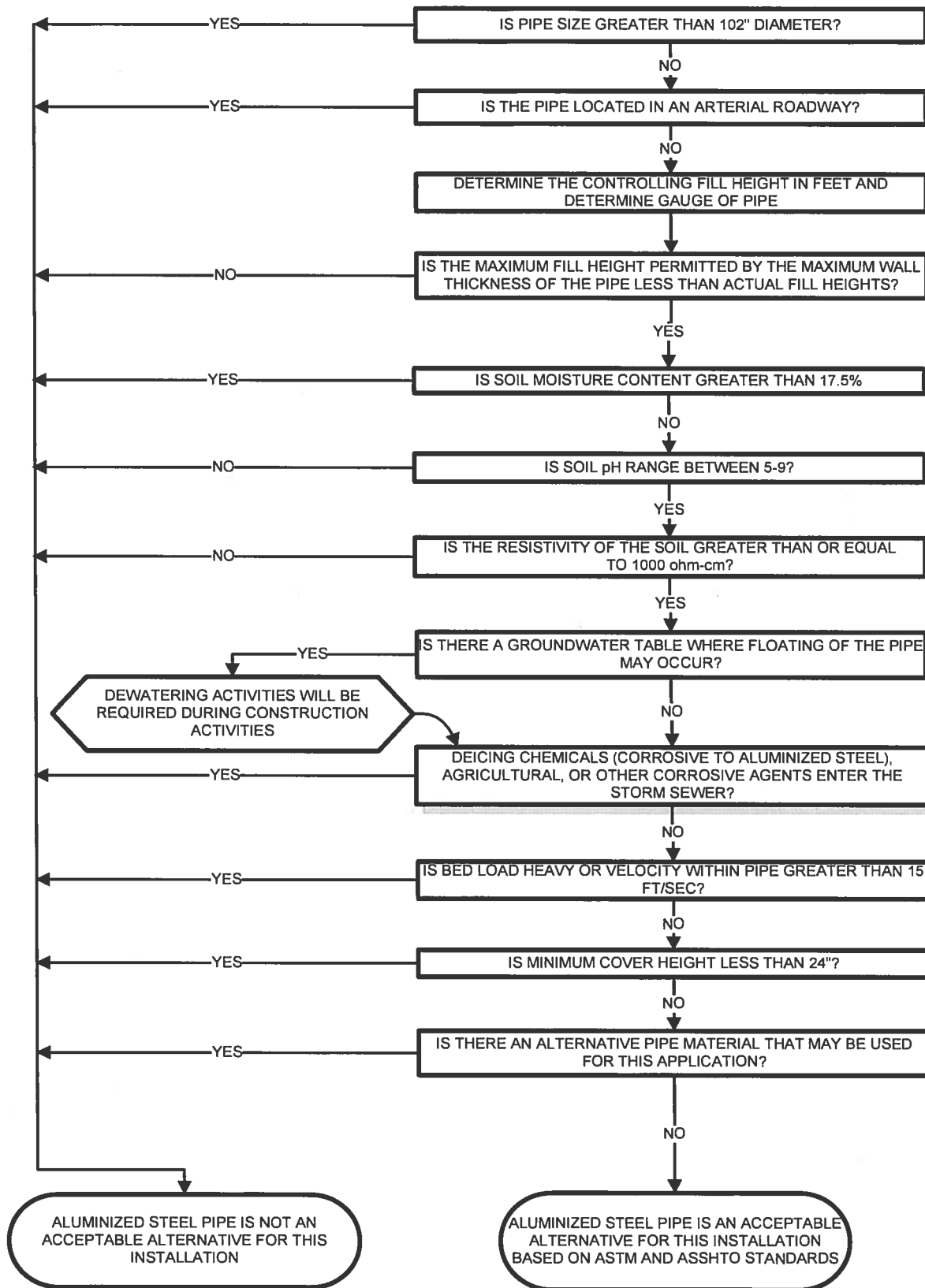



**SECTION 28.00 POLYVINYL CHLORIDE (PVC) STORM SEWER PIPE**

- 28.01 GENERAL
- 28.02 PIPE AND FITTINGS
- 28.03 JOINTS
- 28.04 FITTINGS AND SPECIALS
- 28.05 PIPE SELECTION CHART

## **SECTION 28.00 POLYVINYL CHLORIDE (PVC) STORM SEWER PIPE**

### **28.01 General**

Only those pipeline materials described in this section will be approved for storm sewer installations. All pipe materials to be incorporated in the construction of storm sewers shall conform to the requirements specified herein or as modified elsewhere in these Specifications. Except as modified herein, all materials, manufacturing operations, testing, inspection and marking of polyvinyl chloride (PVC) conform to the requirements of ASTM D2321, ASTM 3212, ASTM 477, ASTM F679 or ASTM F794 latest revision.

Minimum cover of the pipe shall be 2 feet, or one pipe diameter (whichever is less), as determined by ASTM D2321.

THIS MATERIAL IS NOT APPROVED FOR USE WITHIN ARTERIAL ROADWAYS.

### **28.02 Pipe and Fittings**

PVC plastic gravity sewer pipe and fittings shall conform to ASTM F679 or profile wall conforming to ASTM F794, with minimum pipe stiffness of 46 psi.

### **28.03 Joints**

Pipe joints shall be air-tight and of the bell spigot type with elastomeric gaskets conforming to the requirements of ASTM D3212.

### **28.04 Fittings and Specials**

Details of all fittings and specials shall be shown on the drawings for approval by the Engineer before construction. Fittings and specials shall be made of the same material and shall have the same structural qualities as the adjoining pipe. Under no conditions shall the wall thickness be less than the adjoining pipe.

## 28.05 Pipe Selection Chart

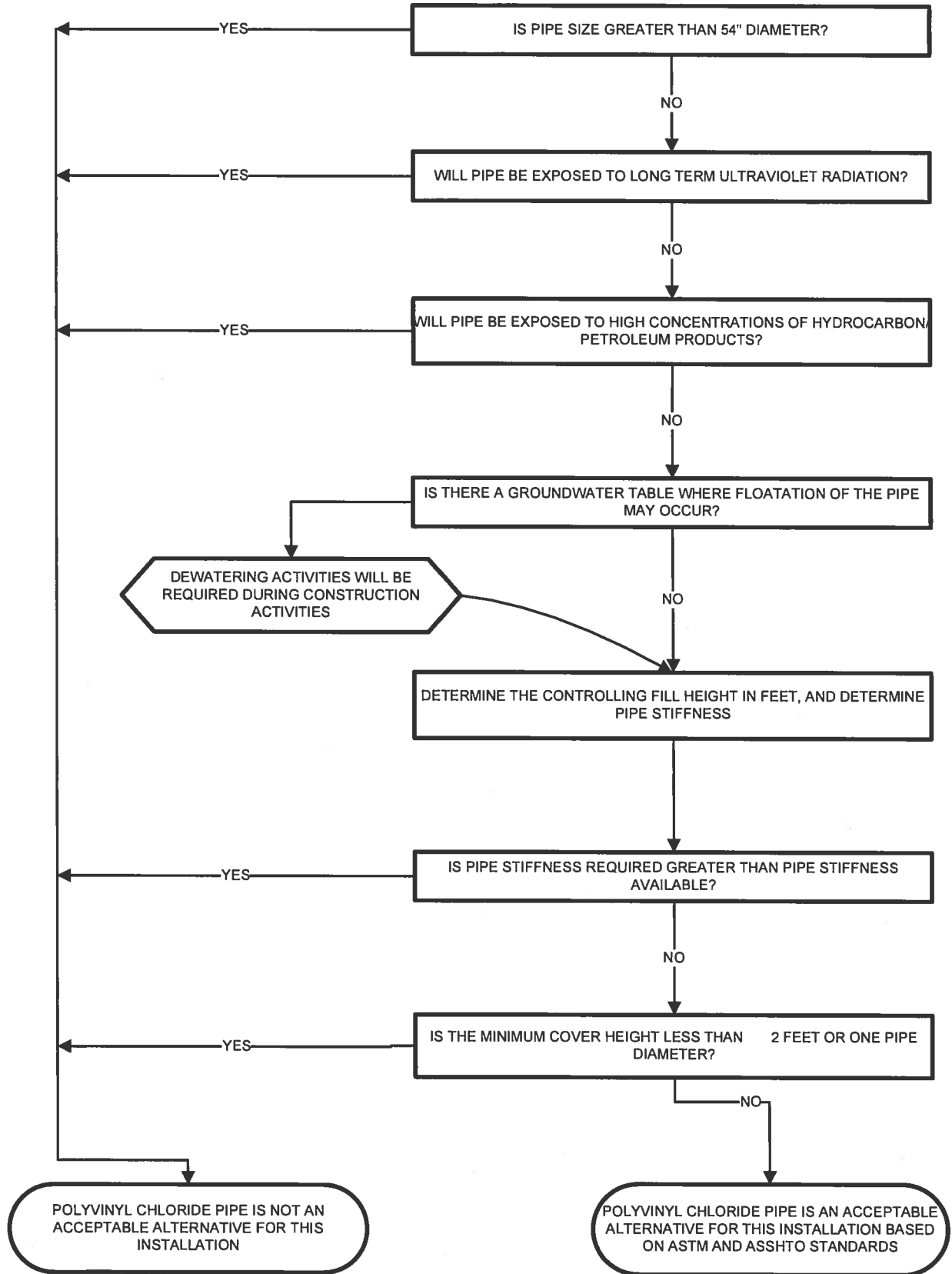

**THIS PAGE IS INTENTIONALLY BLANK**

**SECTION 29.00 HIGH DENSITY POLYETHYLENE (HDPE) STORM  
SEWER PIPE**

- 29.01 GENERAL
- 29.02 BEDDING MATERIAL
- 29.03 PIPE AND FITTINGS
- 29.04 DIAMETER OF PIPE
- 29.05 JOINTS
- 29.06 PIPE SELECTION CHART

## **SECTION 29.00 HIGH DENSITY POLYETHYLENE (HDPE) STORM SEWER PIPE**

### **29.01 General**

Materials and methods in this section may be employed in areas where the depth of cover (top of pipe to subgrade elevation) is 2 foot minimum, or 1 pipe diameter (whichever is greater) but does not exceed 10 feet per AASHTO Section 18.

THIS MATERIAL IS NOT APPROVED FOR USE IN ARTERIAL ROADWAYS.

### **29.02 Bedding Material**

The bedding for all HDPE pipe shall be Class B Alternative Compacted Granular Bedding. Bedding material shall be hand placed under haunches of pipe to ensure uniform support.

### **29.03 Pipe and Fittings**

The pipe and fittings shall be homogenous throughout and free of visible cracks, holes, foreign inclusion, or other injurious defects. The pipe shall be uniform in color, opacity, density, and other physical properties.

HDPE pipe and fittings shall have a smooth interior and corrugated exterior. Eighteen inch through 48 inch pipe shall meet the requirements of AASHTO M294 Type S.

### **29.04 Diameter of Pipe**

The diameter indicated on the approved construction drawings shall mean the nominal inside diameter of the pipe. Nominal inside diameters shall be true to the specified pipe size  $\pm 1/4$  inch.

### **29.05 Joints**

All joints in both pipe and fittings shall be bell and spigot type with gasketed joints to ensure a water-tight connection. The bell shall consist of an integral wall section. The rubber ring shall be according to ASTM F 477. Spigot ends shall be smooth and free of burrs before making the joint. A lubricant, as specified by the pipe manufacturer, shall be applied to the spigot end to prevent damage to the ring and aid in making a tight joint.

## 29.06 Pipe Selection Chart

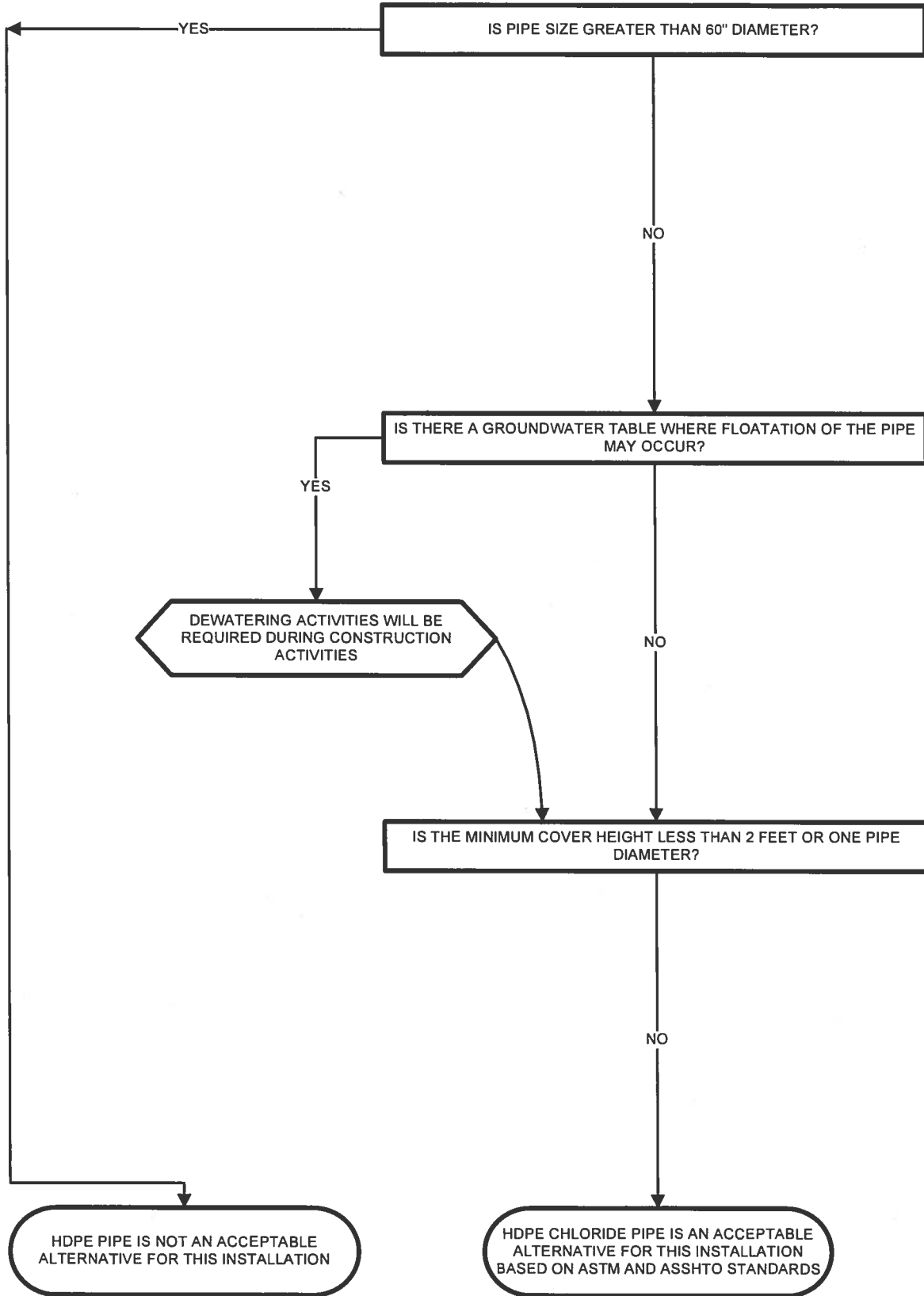

**THIS PAGE IS INTENTIONALLY BLANK**



## **SECTION 30.00 OPEN CHANNELS AND PONDS**

- 30.01 GENERAL
- 30.02 ACCESS
- 30.03 LANDSCAPING
- 30.04 ACCEPTANCE

## **SECTION 30.00 OPEN CHANNELS AND PONDS**

### **30.01 General**

Design and construction for open channels, ponds and hydraulic structures shall conform to City of Aurora Storm Drainage Design and Technical Criteria Manual, latest revision, and Urban Drainage and Flood Control District Urban Storm Drainage Criteria Manual Volumes 1, 2 and 3, latest revision. Aurora Water Engineering Inspectors will inspect all channels and ponds (public and private) for conformance to these standards.

Detention and water quality ponds certified by the consultant and accepted by the city may not be used for temporary sediment ponds during construction without appropriate modification. If an existing detention and water quality pond is to be retrofitted for a sediment pond, then the pond shall need to be re-accepted and re-certified. Sediment pond requirements are outlined in the City of Aurora Rules and Regulations Regarding Stormwater Discharges Associated with Construction Activities, latest revision.

Pond outlets, wingwalls, headwalls and other drainage related facilities are required to have safety railing per Detail S18.1 of City of Aurora Roadway Design and Construction Specifications when there are vertical separations 30 inches or greater 30 feet or less from a designated roadway, trail, sidewalk, pedestrian access or in specific cases as required by the City of Aurora. Refer to City of Aurora Roadway Design and Construction Specifications for railing requirements associated with retaining walls.

All obstructions are prohibited within the 100 year floodplain, including fences. Fences in drainage easements are prohibited except with the express consent of Aurora Water and Aurora Public Works Department.

The following additional requirements apply to open channels and ponds maintained by Aurora Water:

### **30.02 Access**

#### **30.02.1 Open Channels**

Continuous all-weather vehicular maintenance access twelve feet in width is required for the entire length of an open channel. Recycled asphalt and recycled concrete are prohibited for this application. Access may be combined with regional trails and/or sanitary sewer access roads at the discretion of Aurora Water. Additionally, access is required to the channel bottom both

upstream and downstream of all grade control drop structures. Appropriate turnarounds shall be provided as required by Aurora Water Engineering. Maximum slope for maintenance-only trails is 10%. Access Maximum slope for multi-purpose regional trails shall be at the discretion of City of Aurora Parks Recreation and Open Space Department.

### **30.02.2 Ponds**

Continuous all-weather vehicular maintenance access ten feet in width is required to the bottom of the pond including the outlet structure and forebay. Recycled asphalt and recycled concrete are acceptable alternatives for this application. Access is also required to the top of the outlet structure at all times (i.e. when pond is full). If the outlet structure is not built into the pond bank, a catwalk extending from the nearest vehicular access to the outlet structure shall be required. Low flow channels shall be a minimum of 6 feet in width.

## **30.03 Landscaping**

Permanent vegetative landscaping shall consist solely of non irrigated native grasses. Seed mix shall conform to City of Aurora Rules and Regulations Regarding Stormwater Discharges Associated with Construction Activities. Trees, shrubs, bushes, mulch, etc. are prohibited in any tract or easement to be maintained by Aurora Water. Any variances to this requirement must be specifically pre-approved by Aurora Water by submitting a landscaping plan directly to Aurora Water Engineering. Permanent irrigation systems are prohibited on any pond or open channel for which Aurora Water has surface maintenance responsibilities.

## **30.04 Acceptance**

### **30.04.1 Initial Acceptance**

Channels, ponds and hydraulic structures are eligible for initial acceptance once all construction as outlined in the plans is complete. An initial acceptance walk through shall be required with representatives of Aurora Water Environmental Inspections, Aurora Water Engineering and Aurora Water Storm Drain. Additionally the walk through may include Aurora Parks, Recreation and Open Space, Aurora Public Works and Urban Drainage and Flood Control District as necessary. A notice of discrepancies or notification of initial acceptance will be forwarded to the contractor/developer within two weeks of the initial walk through.

### **30.04.2 Final Acceptance**

Hydraulic structures to be maintained by the City require a one year warranty period before final acceptance. The one year warranty period begins on the date of initial acceptance. Final acceptance for pond and channel vegetation will not be issued until vegetation has reached 70%

of pre-construction vegetative density or the required vegetative density as approved in the SWMP has been achieved, and the Storm Water Quality Discharge Permit is closed out if applicable. City of Aurora will assume maintenance responsibility once final acceptance has been issued.

## APPENDIX A - DETAILS

### 100 SERIES – GENERAL

100-1	CITY OF AURORA PIPE BEDDING CLASSES
100-2	CITY OF AURORA PIPE BEDDING CLASSES
101-1	STANDARD MANHOLES
101-2	MANHOLE BASE DETAIL
101-3	DROP MANHOLE
101-4	TYPICAL MANHOLE CHANNELS
101-5	PIPE CONFIGURATION INTO MANHOLE
102-1	24" MANHOLE RING AND COVER
102-2	24" MANHOLE ADJUSTMENT RING
102-3	24" MANHOLE ADJUSTMENT RING
103	30" MANHOLE RING AND COVER
104	36" RING AND COVER
105-1	MANHOLE STEP
105-2	MANHOLE STEP
106	LANDING PLATFORM
107	TYPICAL STEEL ENCASEMENT CONSTRUCTION
108	TYPICAL UTILITY LOCATIONS
109	TYPICAL UTILITY LOCATIONS FOR CURVED STREETS
110	TYPICAL UTILITY LOCATIONS FOR CUL-DE-SACS

### 200 SERIES – WATER

200	METER INSTALLATION PROCEDURES
201	METER INSTALLATION ¾" AND 1" SERVICE
202-1	METER PIT COVER
202-2	METER INSTALLATION ¾" MASTER SERVICE
203-1	MULTI METER VAULT
203-2	MULTI METER VAULT
204-1	1 ½" DISC AND 2" TURBINE IRRIGATIONS METER VAULT
204-2	3" AND 4" TURBINE IRRIGATION METER VAULT
205	1 ½" AND 2" DISC METERS FOR DOMESTIC SERVICE
206	3" AND 4" COMPOUND METER FOR DOMESTIC SERVICE
207	24" WATER METER PIT RING AND COVER
208-1	FIRE HYDRANT ASSEMBLY
208-2	FIRE HYDRANT BOLLARDS
209	2" BLOWOFF
210-1	6" BLOWOFF FOR DIP OR PVC
210-2	6" BLOWOFF FOR STEEL
211-1	2" AIR VACUUM VALVE INSTALLATION
211-2	2" AIR VACUUM VALVE INSTALLATION
211-3	AIR VACUUM VALVE ACCESS MANHOLE
212	BUTTERFLY VALVE INSTALLATION
213	TYPICAL CHECK VALVE STATION
214	VALVE BOX SUPPORT PLATE AND VALVE OPERATOR EXTENSION

## **200 SERIES – WATER (CONT)**

215	VENT PIPE INSTALLATION DETAILS
216	6" DIAMETER VENT PIPE SCREEN
217	RESIDENTIAL VENT PIPE ASSEMBLY
218	ADJUSTABLE STEEL PIPE VALVE SUPPORT
219	SACRIFICIAL ANODE INSTALLATION
220	REFERENCE POST
221	THRUST BLOCK LOCATION, BEARING AREAS AND VOLUMES
222	WATERLINE LOWERING DETAIL
223-1	THRUST BLOCK AND RESTRAINT FOR FIRE SUPPRESSION LINES
223-2	THRUST BLOCK AND RESTRAINT FOR FIRE SUPPRESSION LINES
223-3	THRUST BLOCK AND RESTRAINT FOR FIRE SUPPRESSION LINES
223-4	THRUST BLOCK AND RESTRAINT FOR FIRE SUPPRESSION LINES
224	BACKFLOW PREVENTION DEVICE
225	BACKFLOW PREVENTOR DRAIN FLOW CHART
226	BACKFLOW PREVENTION TYPICAL INSTALLATION
227	TYPICAL DOUBLE CHECK VALVE ASSEMBLY
228-1	IRRIGATION SYSTEM PRESSURE TYPE VACUUM BREAKER
228-2	IRRIGATION SYSTEM PRESSURE TYPE VACUUM BREAKER
228-3	IRRIGATION SYSTEM INSTALLATION FOR CONTINUOUS SERVICE
229	CUT-OFF WALL FOR DITCH OR CANAL CROSSING
230	IN-LINE ANCHOR

## **300 SERIES – SANITARY SEWER**

300	SANITARY SEWER SERVICE DETAIL
301	SANITARY SEWER CLEANOUT
302	PRIVATE UNDERDRAIN CLEAN-OUT CONNECTION
303	GREASE INTERCEPTORS
304	SAND AND OIL INTERCEPTORS
305	ACID NEUTRALIZATION UNIT

## **400 SERIES – STORM SEWER**

400-1	24" TYPE R INLET RING AND COVER
400-2	CURB OPENING INLET TYPE R MODIFIED
400-3	CURB OPENING INLET TYPE R MODIFIED
400-4	CURB OPENING INLET TYPE R MODIFIED
400-5	CURB OPENING INLET TYPE R MODIFIED
400-6	CURB OPENING INLET TYPE R MODIFIED
400-7	CURB OPENING INLET TYPE R MODIFIED
400-8	SPECIAL RETROFIT CURB OPENING INLET TYPE R MODIFIED
400-9	TYPE R INLET GREATER THAN 15' LENGTH
401	INLET CONNECTION INTO STORM SEWER MAIN
402	CONCRETE CRADLE
403	TYPICAL CONCRETE DRAINAGE PAN
404	LOW FLOW CHANNELS

# STANDARD

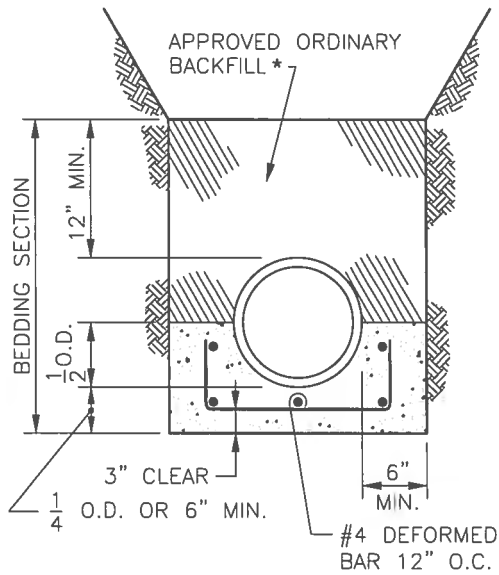

**CLASS A  
CONCRETE CRADLE**

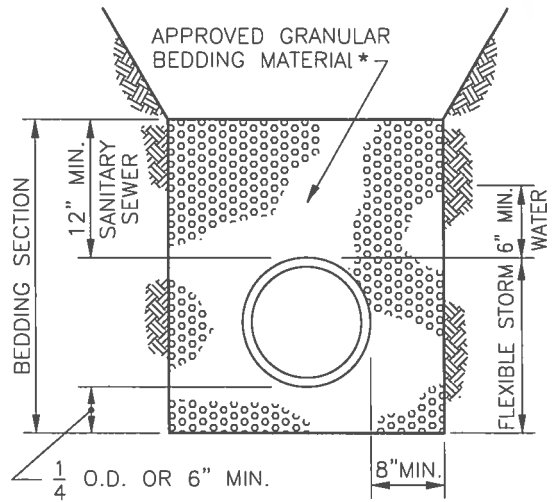

**CLASS B ALTERNATIVE  
COMPACTED GRANULAR  
BEDDING**

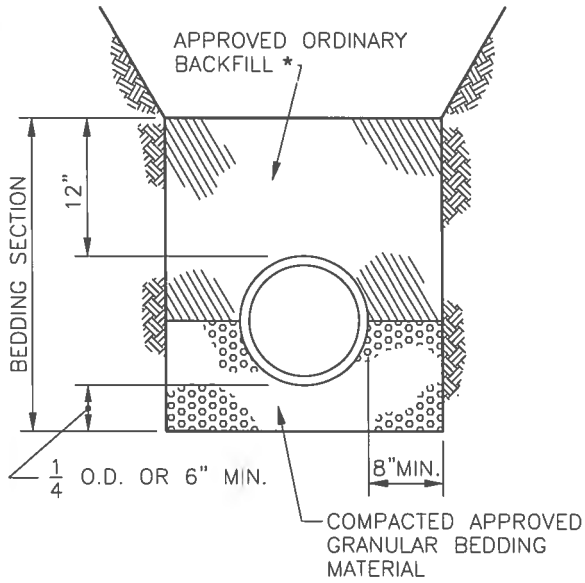

**CLASS B  
COMPACTED GRANULAR  
BEDDING**

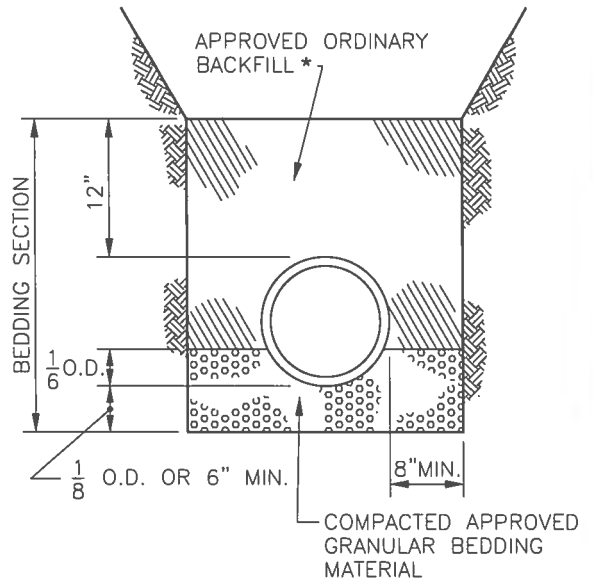

**CLASS C  
COMPACTED GRANULAR  
BEDDING**

NOTE: FOR WATER AND SANITARY SEWER PIPES THERE SHALL BE A MINIMUM OF 12" OF BACKFILL OVER THE PIPE BEFORE OTHER THAN HAND COMPACTION EQUIPMENT IS USED IN THE TRENCH

\* SEE SECTION 9.04 FOR COMPACTION REQUIREMENTS

DRAFT STANDARDS UTIL - STD 100-1

2/5/12  
*Kevin Weger* 2-8-12  
 CITY ENGINEER DATE  
*Chris Z...* 2/8/12  
 AURORA WATER DATE

PIPE BEDDING CLASSES

1 of 2  
100

# STANDARD

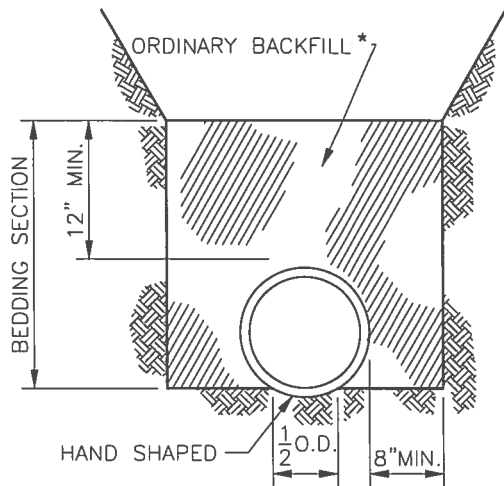

**CLASS C**  
**HAND SHAPED BOTTOM**  
 (SPECIAL AUTHORIZATION REQUIRED)

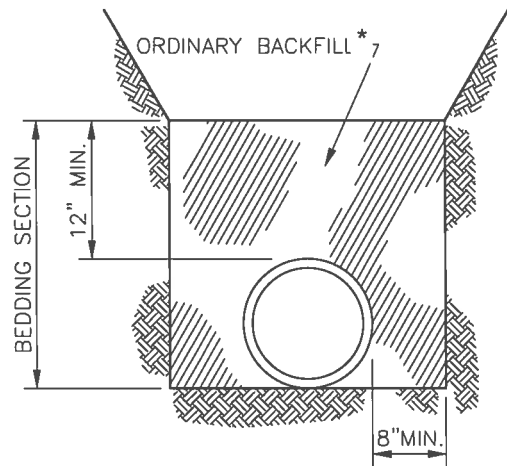

**CLASS D**  
**FLAT BOTTOM**

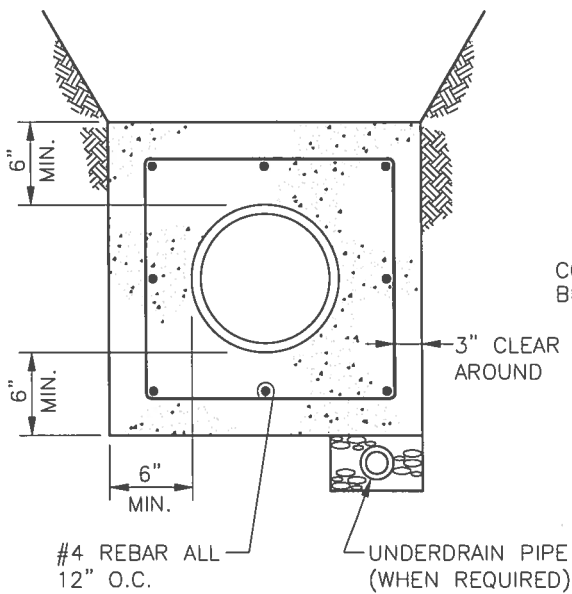

**ENCASEMENT**  
**TYPICAL AND UNDERDRAIN**

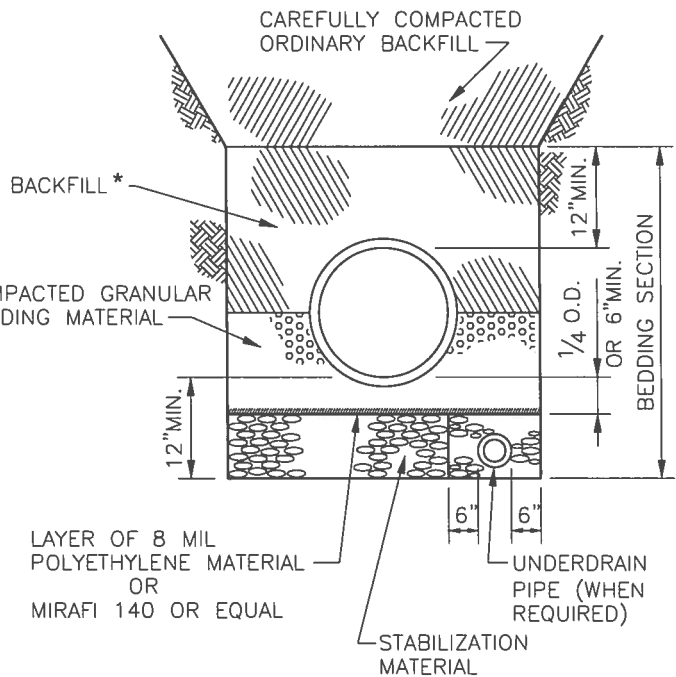

**CLASS B**  
**TYPICAL UNDERDRAIN**  
**OR UNSTABLE TRENCH**

\*SEE SECTION 9.04 FOR COMPACTION REQUIREMENTS

DRAFT STANDARDS\UTL-STDA\100-2

2/8/12 <i>Kevin Weyman</i> CITY ENGINEER	2-8-12 DATE
2/8/12 <i>[Signature]</i> AURORA WATER	2/8/12 DATE

**PIPE BEDDING CLASSES**

2 of 2  
**100**



# STANDARD

## PRECAST MANHOLES ASTM C478

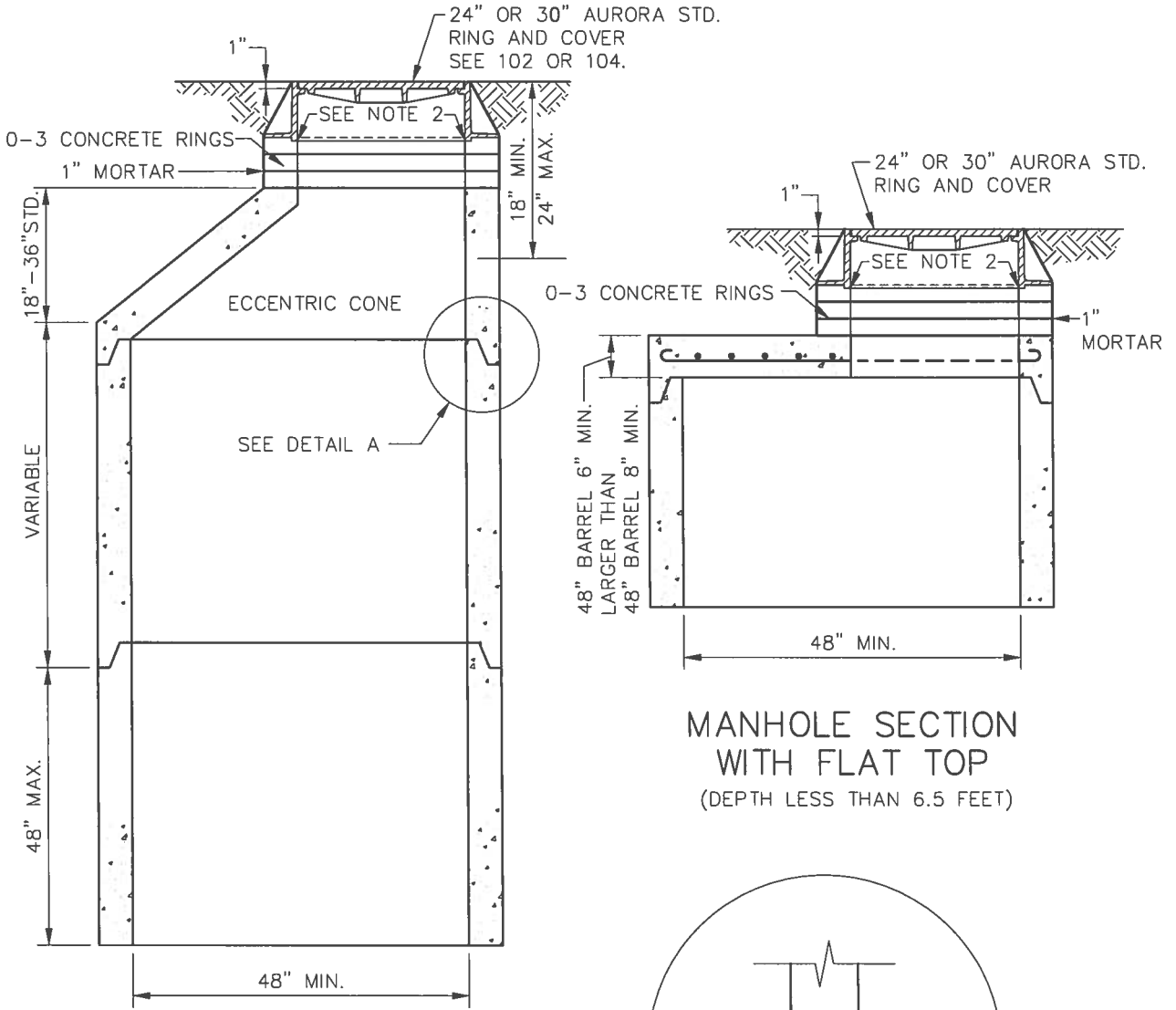

MANHOLE SECTION  
WITH ECCENTRIC CONE TOP

MANHOLE SECTION  
WITH FLAT TOP  
(DEPTH LESS THAN 6.5 FEET)

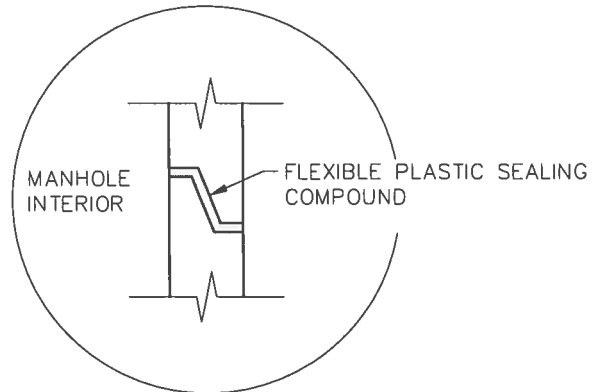

DETAIL A

**NOTES**

1. FLEXIBLE PLASTIC SEALING COMPOUND BETWEEN RING AND CONE OR FLAT LID, OR CONCRETE RING.
2. MINIMUM OF 3 INCHES CLEARANCE BETWEEN ANY PIPE PENETRATION AND THE ECCENTRIC CONE SECTION OR FLAT LID.

DRAFT\STANDARDS\UTIL-STD\101-1

<i>1/23/12</i> <i>Kevin Weyers</i> CITY ENGINEER	2-6-12 DATE
<i>Chris 2 SA</i> AURORA WATER	2/7/12 DATE

STANDARD MANHOLES

1 of 5  
101

# STANDARD

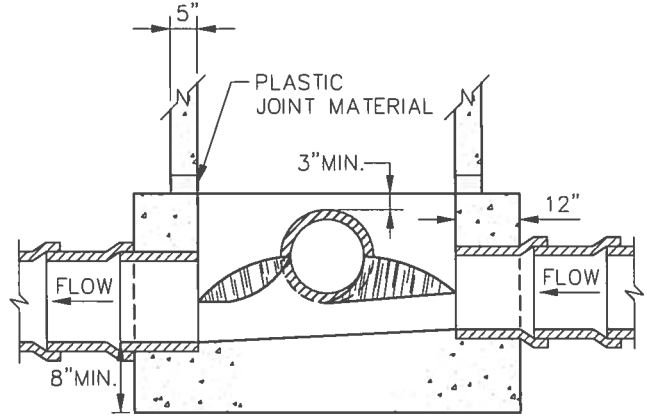
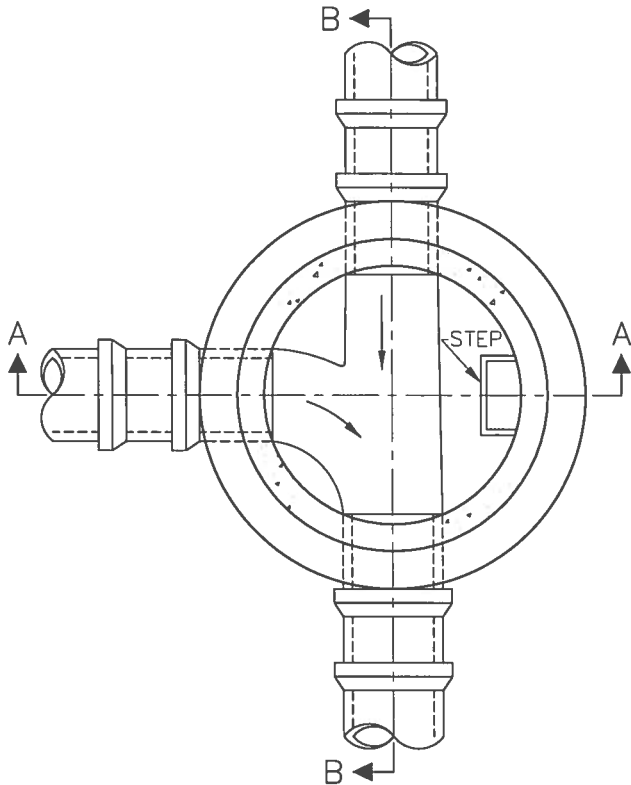

SECTION B-B

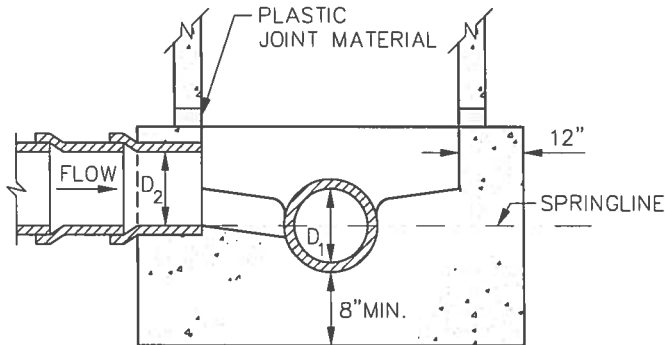

SECTION A-A

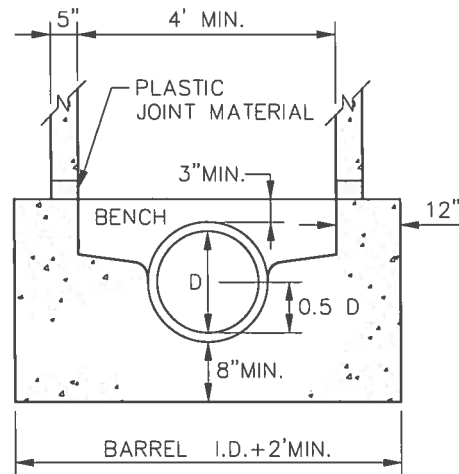

MONOLITHIC BASE

**NOTES**

1. STRAIGHT PIPE SECTIONS MAY BE LAID THROUGH THE MANHOLE WITH CROWN REMOVED.
2. UNIFORM PIPE SIZE SECTION NOT LAID THROUGH THE MANHOLE SHALL DROP A MIN. OF 0.2 FEET.
3. BENCHES SHALL SLOPE 1 INCH/FT.
4. THERE SHALL BE A JOINT MADE AT THE EDGE OF MANHOLE BASE.
5. THE OUTSIDE WALLS SHALL BE FORMED TO THE DESIGNED SHAPE.
6. THE TOP OF THE BASE SHALL BE LEVEL IN ALL CASES.

DRAFT\STANDARDS\UTL-STD\101-2

<i>1/25/12</i> <i>Kevin Wegner</i> CITY ENGINEER DATE 2-6-12	<i>Chris 2 SA</i> AURORA WATER DATE 2/7/12
---	--

MANHOLE BASE DETAIL

2 of 5

101

# STANDARD

DROP MANHOLE ALTERNATE  
 POLYLINE DUCTILE IRON FITTINGS AND PIPE  
 WITH MECHANICAL JOINTS MAY BE USED IN  
 PLACE OF CONCRETE ENCASEMENT.

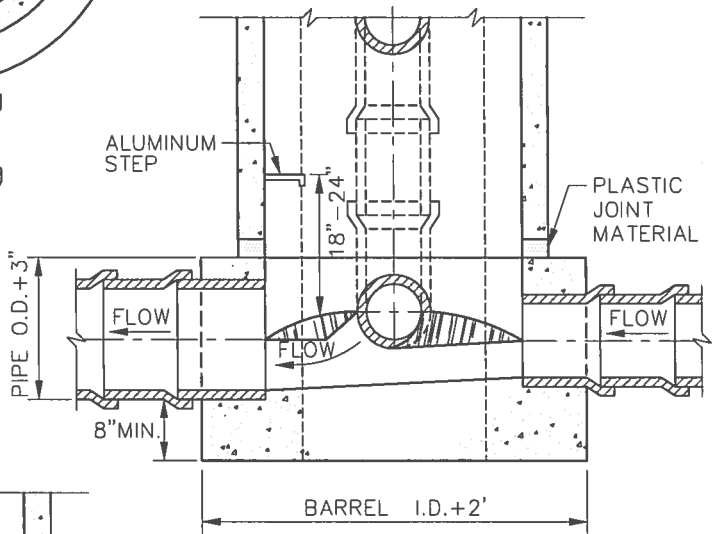
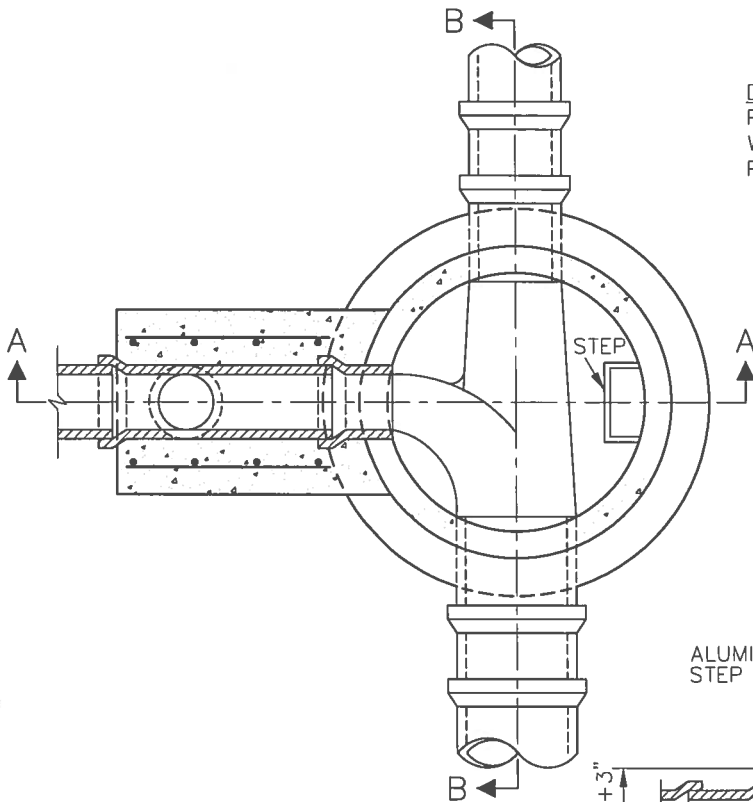

SECTION B-B

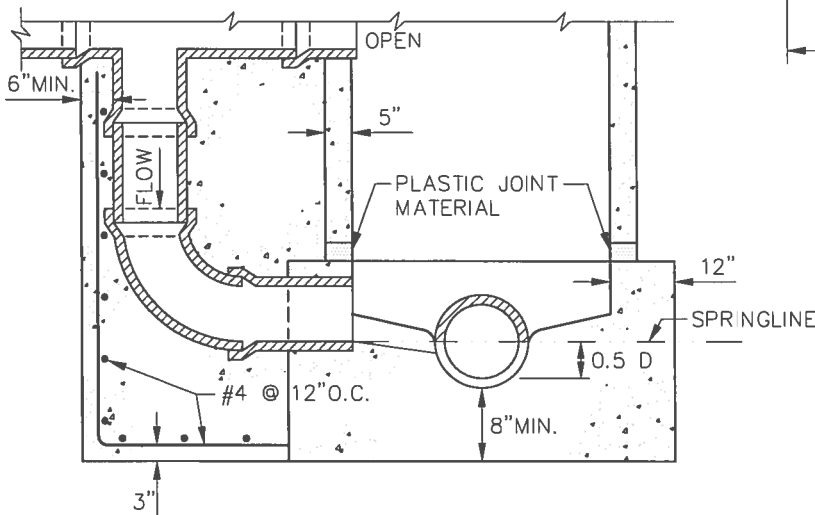

SECTION A-A

**NOTES**

1. STRAIGHT PIPE SECTIONS MAY BE LAID THROUGH THE MANHOLE WITH CROWN REMOVED WITH APPROVAL.
2. UNIFORM PIPE SIZE SECTION NOT LAID THROUGH THE MANHOLE SHALL DROP A MIN. OF 0.2 FEET, 0.3 FEET AT DEFLECTED MANHOLES.
3. BENCHES SHALL SLOPE 1 INCH/FT.
4. THERE SHALL BE A JOINT MADE AT THE EDGE OF MANHOLE BASE.
5. THE OUTSIDE WALLS SHALL BE FORMED TO THE DESIGNED SHAPE.
6. THE TOP OF THE BASE SHALL BE LEVEL IN ALL CASES.
7. ENCASEMENT SHALL BE EXTENDED TO THE SPRINGLINE OF PIPE.
8. INSIDE DROP MANHOLES ARE NOT ALLOWED.

DRAFT STANDARDS UTIL - STD 101 - 3

1/23/12  
 Kevin Wegener 2-6-12  
 CITY ENGINEER DATE  
 Roy S. G. 2/7/12  
 AURORA WATER DATE

**DROP MANHOLE**

3 of 5  
**101**

# STANDARD

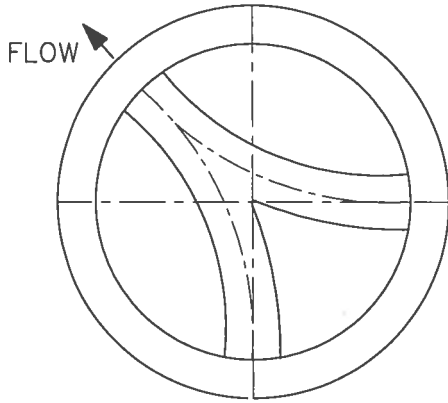

(Y) SWEEP

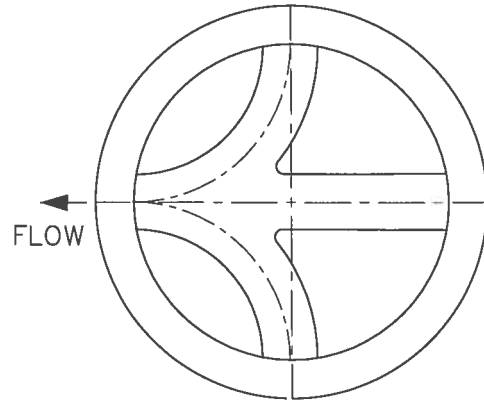

(T) SWEEP

**NOTES**

1. MAINTAIN PIPE CURVATURE THROUGHOUT THE CHANNEL.
2. APRON SHOULD BE SLIGHTLY SLOPED TO ALLOW FOR COMFORTABLE STANDING BY A WORKER.

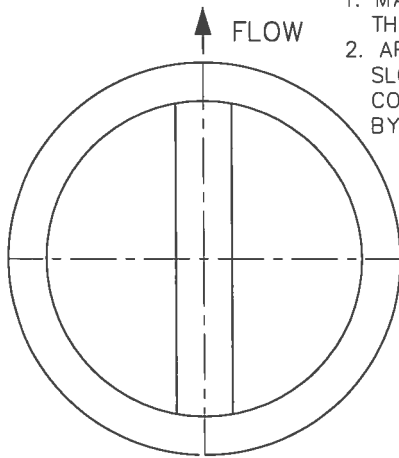

STRAIGHT

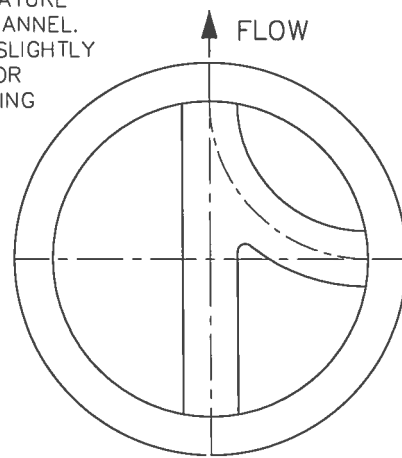

90 DEGREE (Y) SWEEP

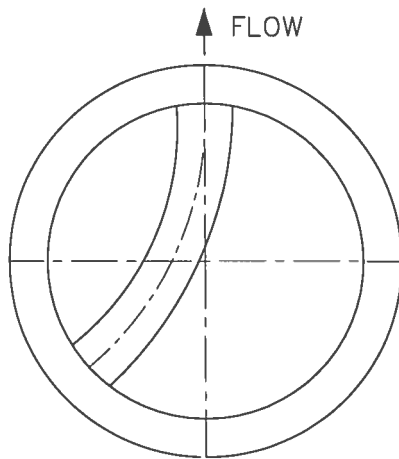

VARIABLE SWEEP

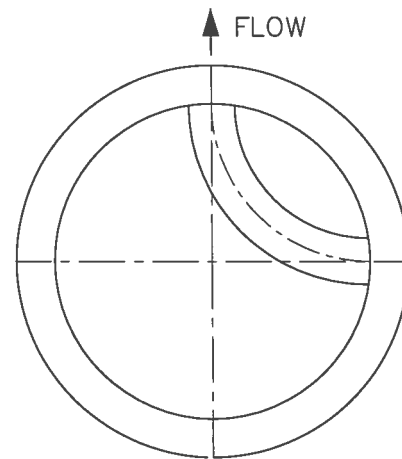

90 DEGREE SWEEP

DRAFT\STANDARDS\UTIL--STD\101--4

<p><i>KE</i> 1/23/12 <i>Kern Wegener</i> 2-6-12 CITY ENGINEER      DATE</p> <p><i>Chris Jones</i> 2/7/12 AURORA WATER      DATE</p>	<p style="text-align: center;"><b>TYPICAL MANHOLE CHANNELS</b></p>
---	--

4 of 5

101

# STANDARD

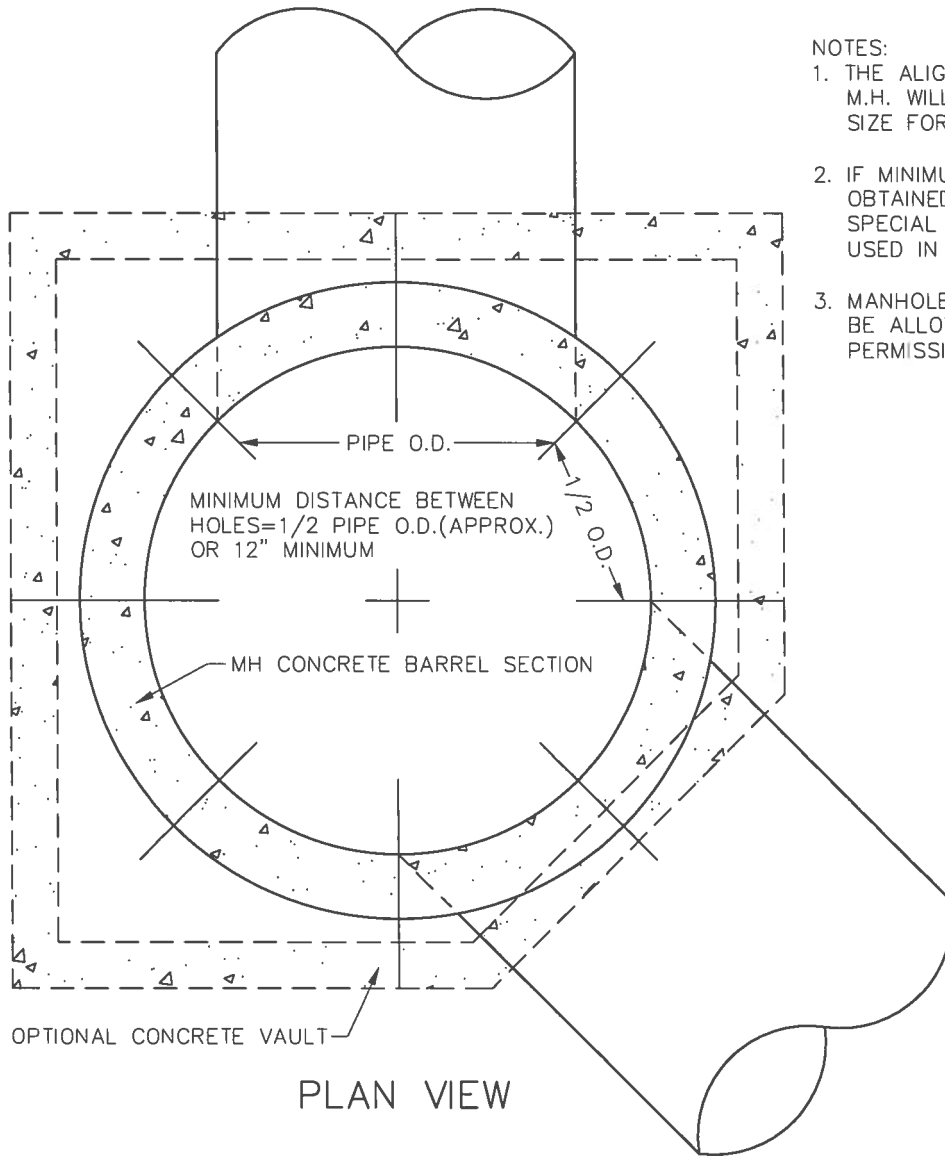

**NOTES:**

1. THE ALIGNMENT OF PIPES INTO THE M.H. WILL DETERMINE THE BARREL SIZE FOR THE SIZE OF PIPE USED.
2. IF MINIMUM DISTANCES CANNOT BE OBTAINED DUE TO PIPE DIAMETERS, A SPECIAL CONCRETE VAULT SHALL BE USED IN PLACE OF A STANDARD M.H.
3. MANHOLES LARGER THAN 72" WILL BE ALLOWED WITH SPECIAL WRITTEN PERMISSION OF THE ENGINEER.

PLAN VIEW

THE INTERNAL DIAMETER OF THE M.H. BARREL SHALL BE:

SANITARY SEWER		STORM SEWER	
PIPE SIZE	BARREL SIZE	PIPE SIZE	BARREL SIZE
12" or LESS	48"	27" or LESS	60"
15" to 27"	60"		
30" to 48"	72"	30" to 48"	72"

DRAFT\STANDARDS\UTIL-STD\101-5

*Kim Wejver* 2-6-12  
 CITY ENGINEER DATE  
*Cheryl* 2/7/12  
 AURORA WATER DATE

MANHOLE BASE DETAIL

5 of 5  
**101**

# STANDARD

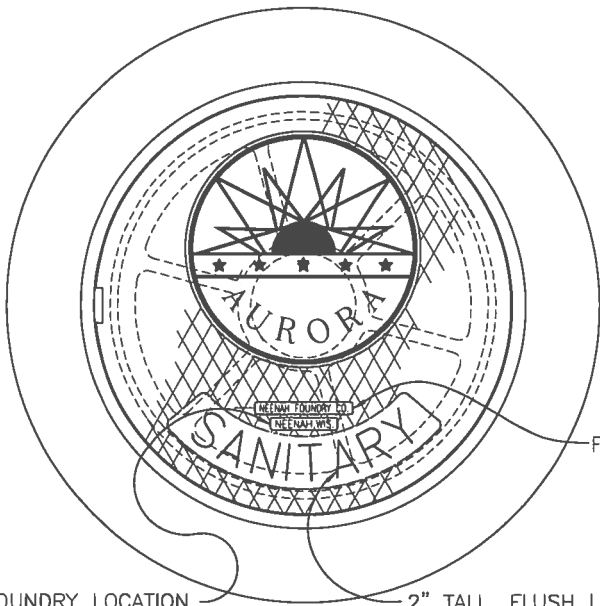

FOUNDRY LOCATION  
CITY, STATE

2" TALL, FLUSH LETTERS

FOUNDRY NAME

TOP VIEW

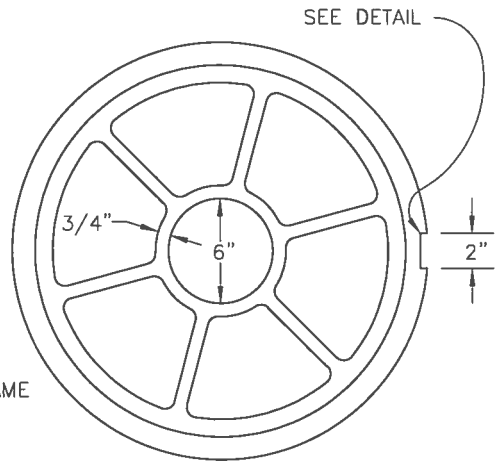

SEE DETAIL

UNDERSIDE VIEW  
OF COVER

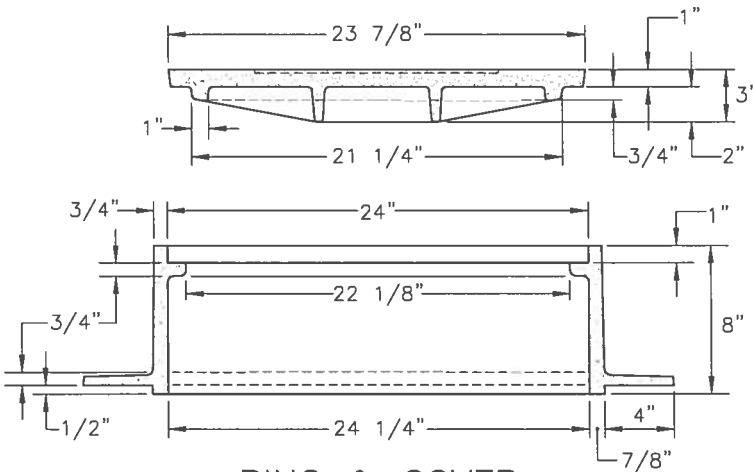

RING & COVER

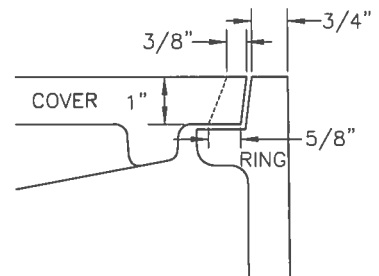

DETAIL-LIFTING NOTCH

**NOTES:**

1. A.S.T.M. DESIGNATION A-48-83 CLASS 25B (UNPAINTED).
2. ALL BEARING SURFACES TO BE MACHINED.
3. LETTERING ON COVER AS REQUIRED (WATER, SANITARY, OR STORM).
4. AURORA STANDARD-NEENAH R-1706, OR EQUAL, TOTAL MINIMUM WEIGHT APPROXIMATELY 224 LBS, MINIMUM FRAME WEIGHT -114 LBS, MINIMUM LID WEIGHT-110 LBS.
7. LIFTING NOTCH SHALL NOT EXTEND PAST INSIDE FACE OF RING SEAT.
6. SEE SECTION 10.00 FOR SPECIFICATIONS.

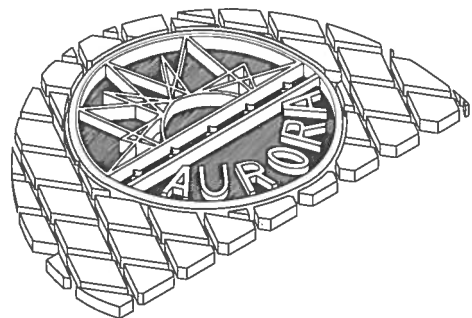

DETAIL-COVER DESIGN

TYPE "C" DESIGN: 1"X 1" SCORED 1/32"± DEEP

DRAFT STANDARDS UTIL-STD\102-1

*Kevin Wejver* 2-6-12  
 CITY ENGINEER DATE  
*Chris 25th* 2/7/12  
 AURORA WATER DATE

**24" MANHOLE  
RING & COVER**

1 of 3  
**102**

STANDARD

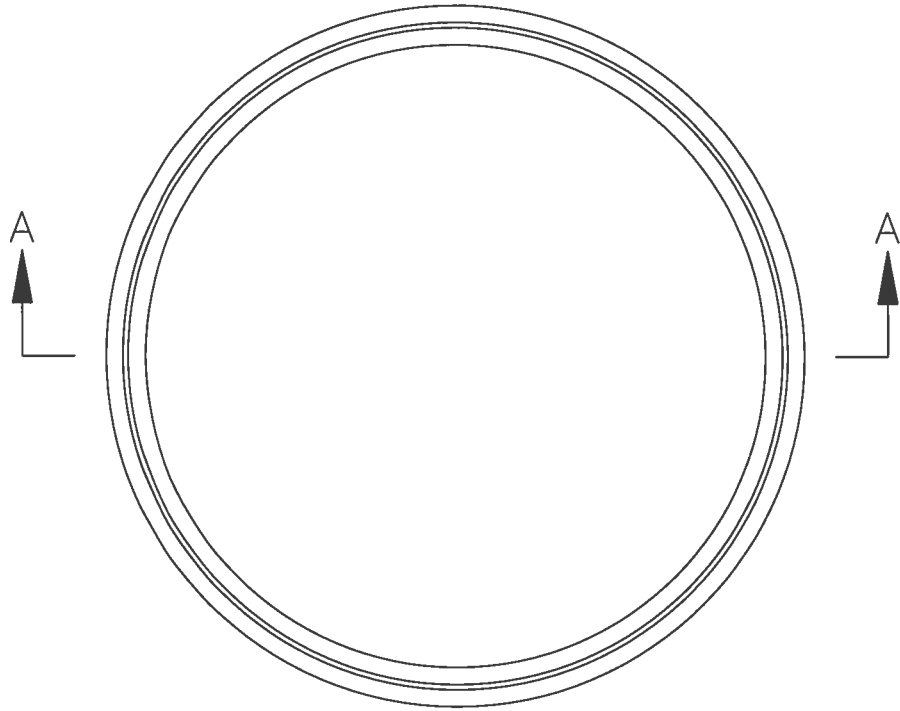

PLAN

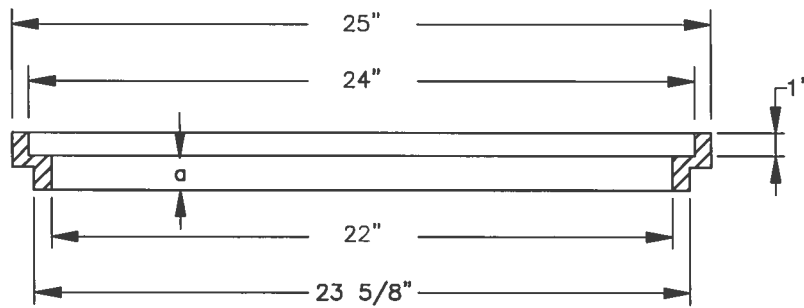

SECTION A-A

DRAFT\STANDARDS\UTIL-STD\102-2

*1/23/12*  
*Kevin Wezener* 2-6-12  
CITY ENGINEER DATE  
*Chris J. [Signature]* 2/7/12  
AURORA WATER DATE

24" MANHOLE  
ADJUSTMENT RING

2 of 3  
102

# STANDARD

## NOTES

1. DIMENSION SHOWN IN **BOLD** SHALL HAVE A TOLERANCE OF  $\pm 1/16$  "
2. DIMENSION **a** (RISER HEIGHT) =  $1 \frac{5}{16}$  ",  $1 \frac{1}{2}$  ",  $2$  ",  $2 \frac{1}{2}$  ",  $3$  " or  $4$  "
3. ALL OTHER DIMENSIONS SHALL HAVE A TOLERANCE OF  $\pm 1/4$  "
4. OUTSIDE DIMENSION OF  $23 \frac{3}{4}$  " ON LOWER SECTION OF RING SHALL BE MAINTAINED TO A MINIMUM OF  $1 \frac{1}{4}$  " FROM THE BOTTOM BEARING SURFACE OF THE RING

## SPECIFICATION FOR GRAY CAST IRON RISERS

1. CAST IRON RISERS SHALL CONFORM TO ASTM A48, CLASS 35B AND AASHTO M306
2. BEARING SURFACES BETWEEN MANHOLE RINGS AND COVERS AND FRAMES SHALL BE MACHINED TO PREVENT ROCKING
3. RISERS TO BE OF UNIFORM QUALITY FREE FROM SAND HOLES, GAS HOLES, SHRINKAGE, CRACKS OR OTHER DEFECTS
4. RISERS SHALL BE GROUND SMOOTH AND WELL CLEANED BY SHOT BLASTING
5. EACH RISER SHALL BE STAMPED WITH THE SIZE, NAME OF PRODUCING FOUNDRY, ASTM MATERIAL DESIGNATION, INDIVIDUAL PART NUMBER AND MANUFACTURE DATE

## SPECIFICATION FOR STEEL RISERS

1. STEEL RISERS TO BE MANUFACTURED WITH U.S. MILLED CARBON STEEL CONFORMING TO ASTM A36
2. PROVIDE CONTINUOUS FILLET OR GROOVE WELDS CONFORMING TO AWS D1.1 STRUCTURAL WELDING GUIDE
3. ALL WELDING SHALL BE PERFORMED BY CERTIFIED WELDERS
4. BEARING SURFACES BETWEEN MANHOLE RINGS AND COVERS AND FRAMES SHALL BE MACHINED TO PREVENT ROCKING
5. RISERS TO BE OF UNIFORM QUALITY FREE FROM SHRINKAGE, CRACKS OR OTHER DEFECTS
6. RISERS SHALL BE SMOOTH AND WELL CLEANED
7. EACH RISER SHALL BE STAMPED WITH THE SIZE, NAME OF PRODUCING MILL, ASTM MATERIAL DESIGNATION, INDIVIDUAL PART NUMBER AND MANUFACTURE DATE
8. SET SCREWS TO BE PROVIDED WITH RISERS

DRAFT\STANDARDS\UTIL-STD\102-3

1/23/12  
Kevin Wegener 2-6-12  
CITY ENGINEER DATE  
Chris J. G. 2/7/12  
AURORA WATER DATE

24" MANHOLE  
ADJUSTMENT RING

3 of 3  
102



# STANDARD

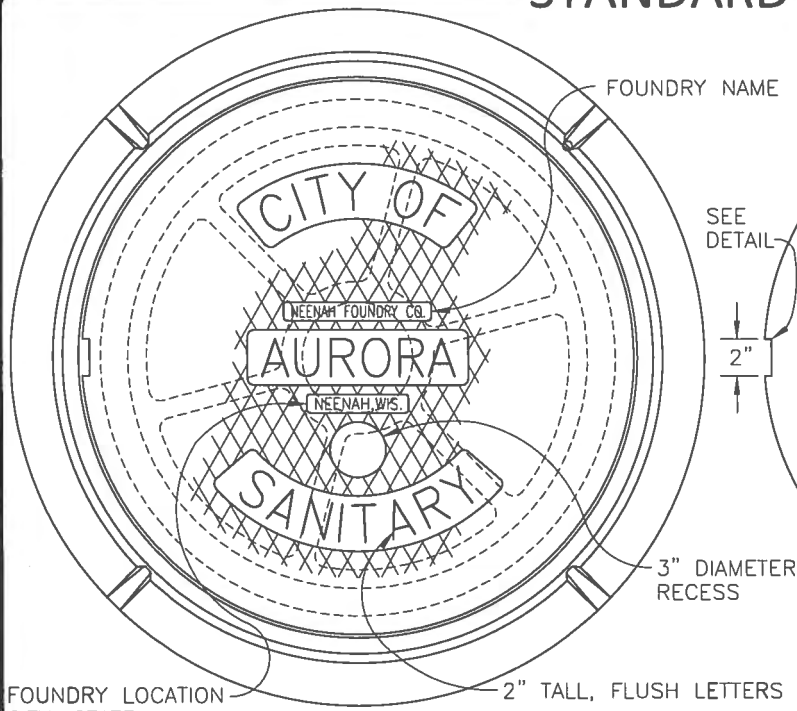

TOP VIEW

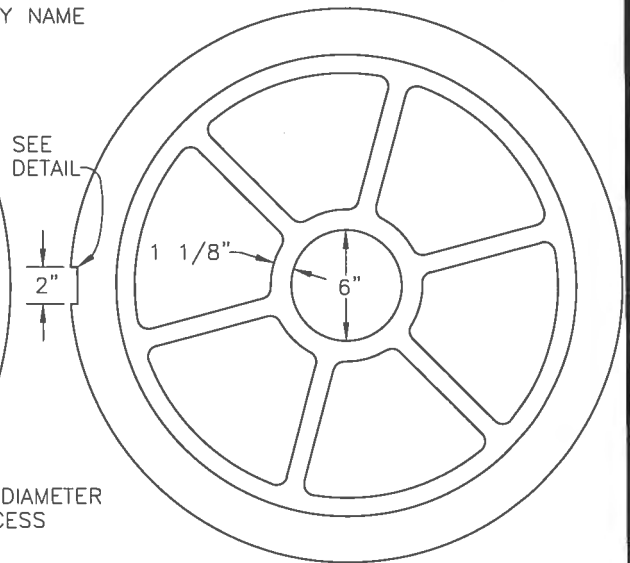

UNDERSIDE VIEW OF COVER

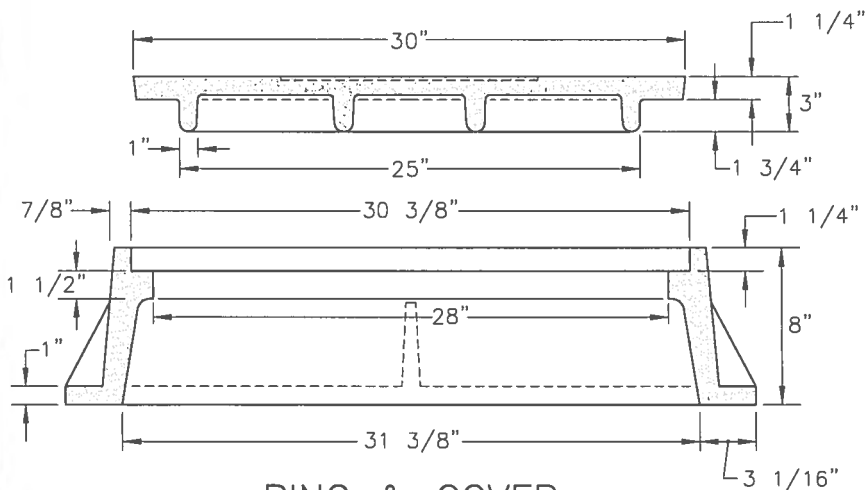

RING & COVER

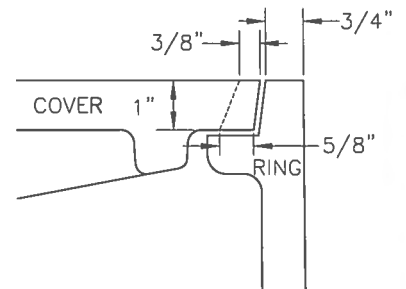

DETAIL-LIFTING NOTCH

**NOTES:**

1. A.S.T.M. DESIGNATION A-48-83 CLASS 25B (UNPAINTED).
2. ALL BEARING SURFACES TO BE MACHINED.
3. LETTERING ON COVER AS REQUIRED (WATER, SANITARY, OR STORM).
4. AURORA STANDARD-NEENAH R-1798, OR EQUAL, TOTAL MINIMUM WEIGHT APPROXIMATELY 575 LBS, MINIMUM FRAME WEIGHT -295 LBS., MINIMUM LID WEIGHT-280 LBS.
7. LIFTING NOTCH SHALL NOT EXTEND PAST INSIDE FACE OF RING SEAT.
6. SEE SECTION 10.00 FOR SPECIFICATIONS.

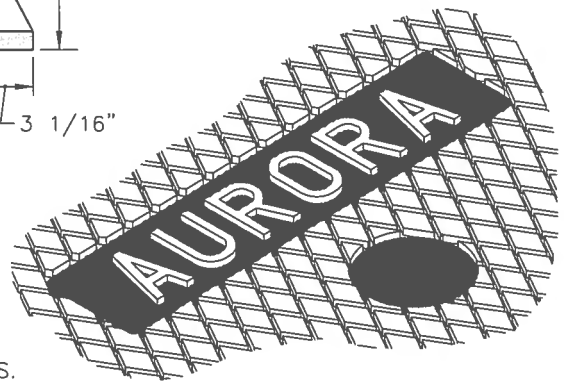

DETAIL-COVER DESIGN

TYPE "C" DESIGN: 1"X 1" SCORED 1/32"± DEEP

DRAFT STANDARDS UTIL-STD-103

*1/25/12*  
*Ken Wegener* 2-6-12  
 CITY ENGINEER DATE  
*Chris Z...* 2/7/12  
 AURORA WATER DATE

**30" MANHOLE  
RING AND COVER**

**103**

STANDARD

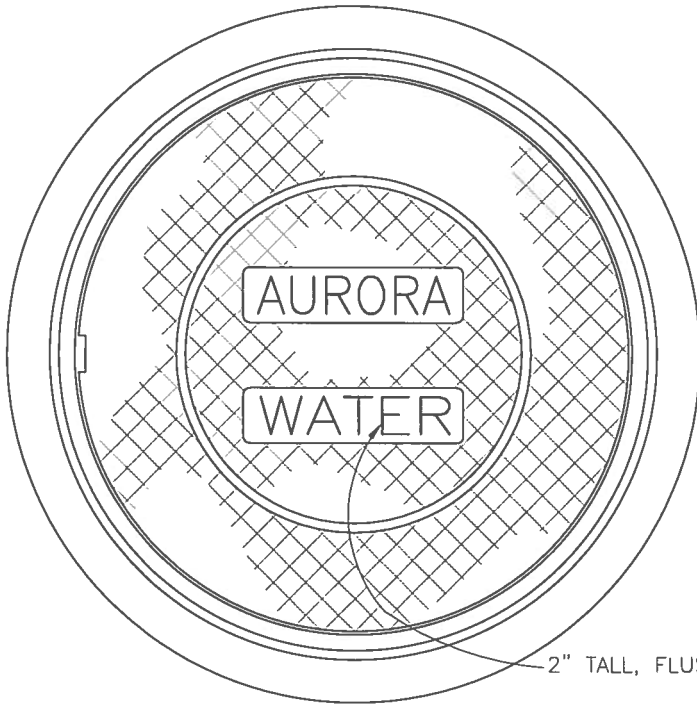

36" LID W/ 22" ACCESS LID  
NEENAH R-1741D OR APPROVED EQUAL

2" TALL, FLUSH LETTERS

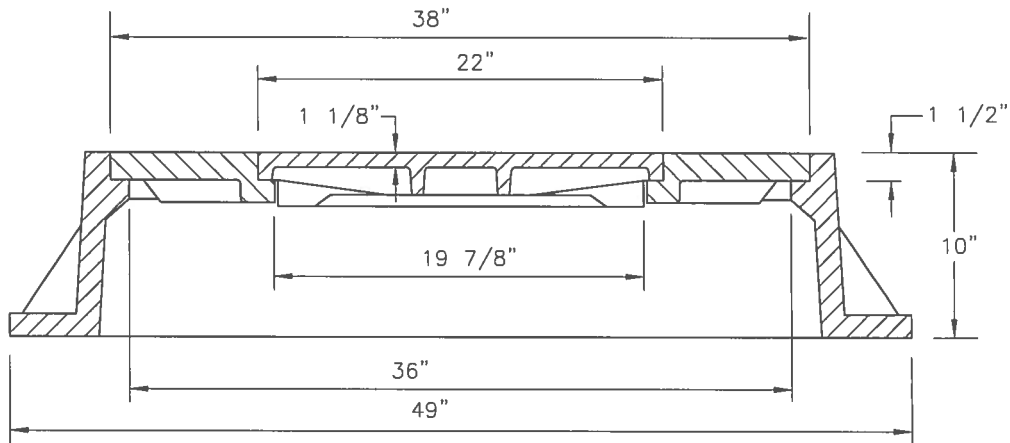

RING & COVER

NOTES:

1. A.S.T.M. DESIGNATION A-48-83 CLASS 25B (UNPAINTED).
2. ALL BEARING SURFACES TO BE MACHINED.
3. LETTERING ON COVER AS REQUIRED (WATER, SANITARY, OR STORM).
4. AURORA STANDARD-NEENAH R-1741, OR EQUAL, TOTAL MINIMUM WEIGHT APPROXIMATELY 350 LBS, MINIMUM FRAME WEIGHT -170 LBS., MINIMUM LID WEIGHT-180 LBS.
7. LIFTING NOTCH SHALL NOT EXTEND PAST INSIDE FACE OF RING SEAT.
6. SEE SECTION 10.00 FOR SPECIFICATIONS.

DRAFT STANDARDS\UTL-STD\104

<i>KEW</i> 1/22/12	<i>Kevin Wegener</i> 2-6-12
CITY ENGINEER	DATE
<i>Chris Z...</i>	2/7/12
AURORA WATER	DATE

36" RING & COVER

104

# STANDARD

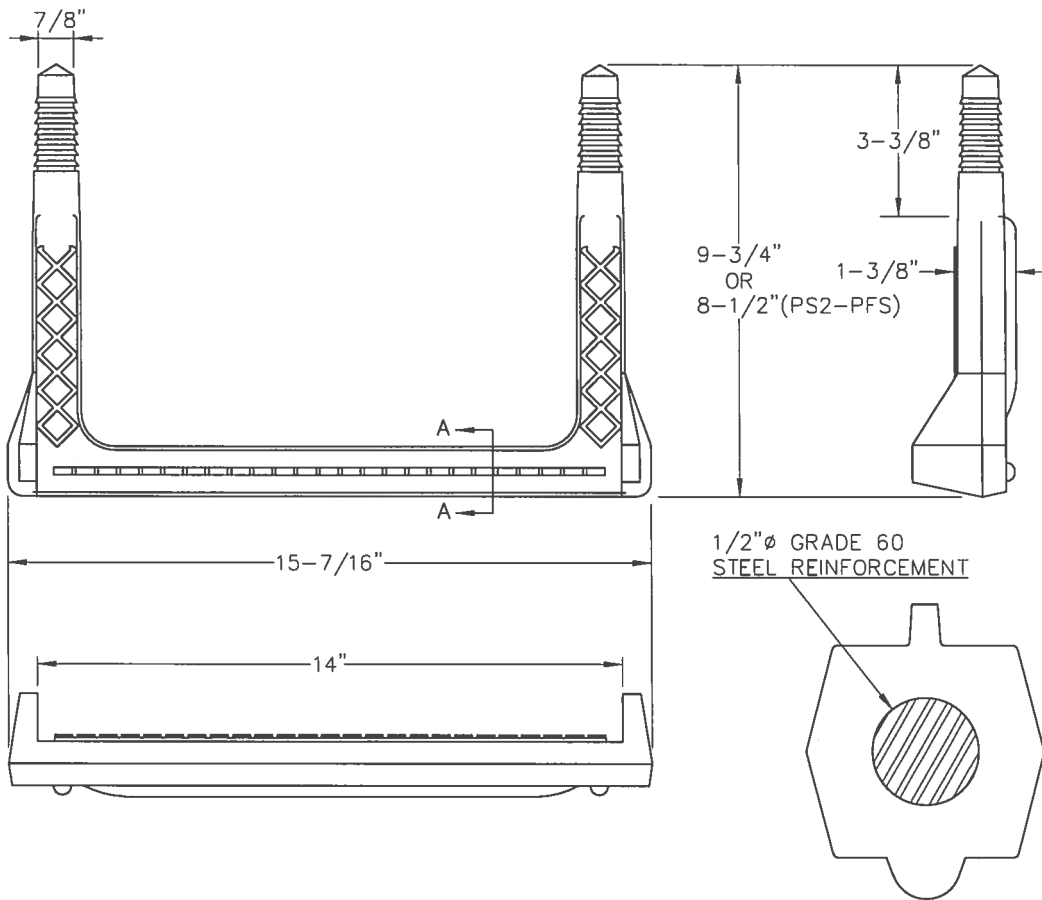

1/2"  $\phi$  GRADE 60  
STEEL REINFORCEMENT

SECTION A-A

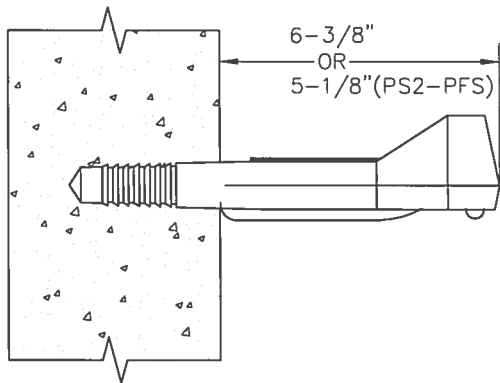

**NOTES:**

1. AS MANUFACTURED BY M.A. INDUSTRIES. PART NO. PS2-PF OR PS2-PFS
2. CAPACITY: 2,500 LBS. WITH STEP EXTENDED 6-3/8" FROM WALL.
3. MATERIAL: COPOLYMER POLYPROPYLENE PLASTIC, WITH 1/2"  $\phi$  GRADE 60 STEEL REINFORCEMENT.

IT SHALL BE THE CONTRACTORS RESPONSIBILITY TO REPLACE TOP STEPS AS NECESSARY WITH MODEL NO. PS2-PF-HH (SEE DETAIL 105-2) IF 20" OF CLEARANCE CANNOT BE MAINTAINED.

DRAFT STANDARDS UTIL - STD 105-1

<p><i>1/23/12</i> <i>Kim Wiegner</i> CITY ENGINEER</p>	<p>2-6-12 DATE</p>
<p><i>Chris 28/12</i> AURORA WATER</p>	<p>2/7/12 DATE</p>

MANHOLE STEP

1 of 2  
**105**

# STANDARD

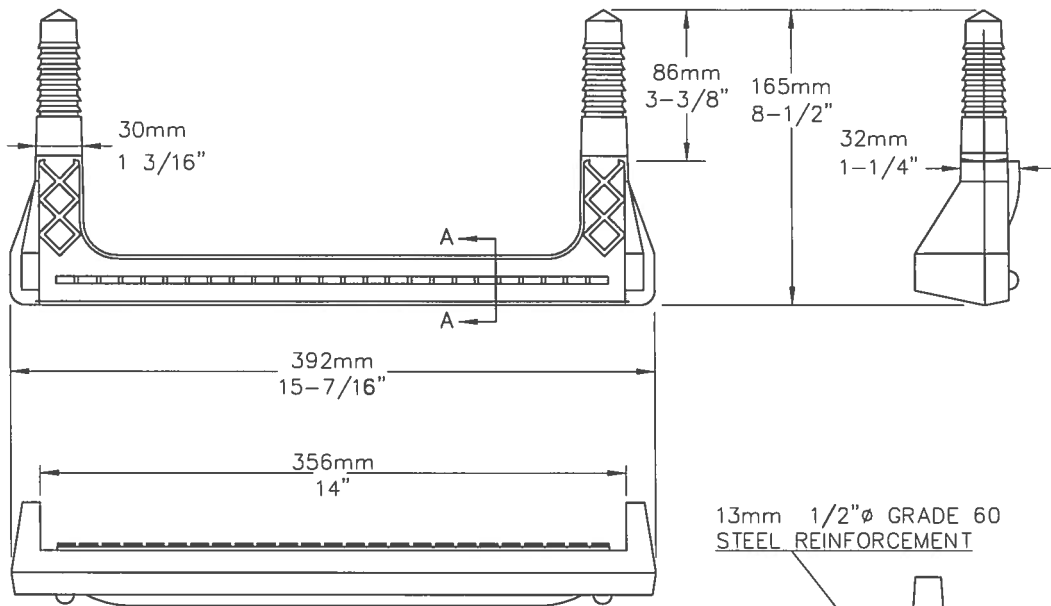

13mm 1/2"Ø GRADE 60  
STEEL REINFORCEMENT

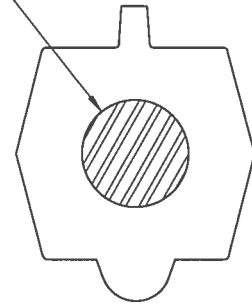

SECTION A-A

COPOLYMER POLYPROPYLENE PLASTIC

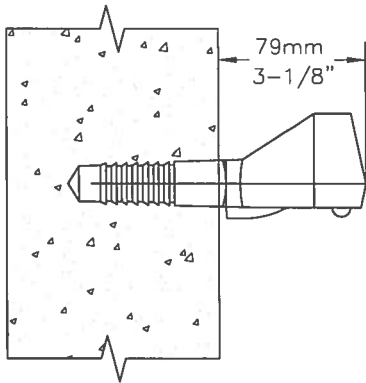

**NOTES:**

1. THIS STEP, PART NO. PS2-PF-HH, AS MANUFACTURED BY M. A. INDUSTRIES, INC. SHALL BE USED WHENEVER 20 INCHES OF CLEARANCE CANNOT BE MAINTAINED AT THE TOP STEP, USING DETAIL 105-1. MEASUREMENT SHALL BE TAKEN FROM THE FACE OF THE STEP TO THE INNER WALL OF THE MANHOLE.

DRAFT\STANDARDS\UTIL-STD\105-2

<i>1/23/12</i> <i>Kevin Wegener</i> CITY ENGINEER	2-6-12 DATE
<i>Chris Z...</i> AURORA WATER	2/7/12 DATE

MANHOLE STEP

2 of 2

105

# STANDARD

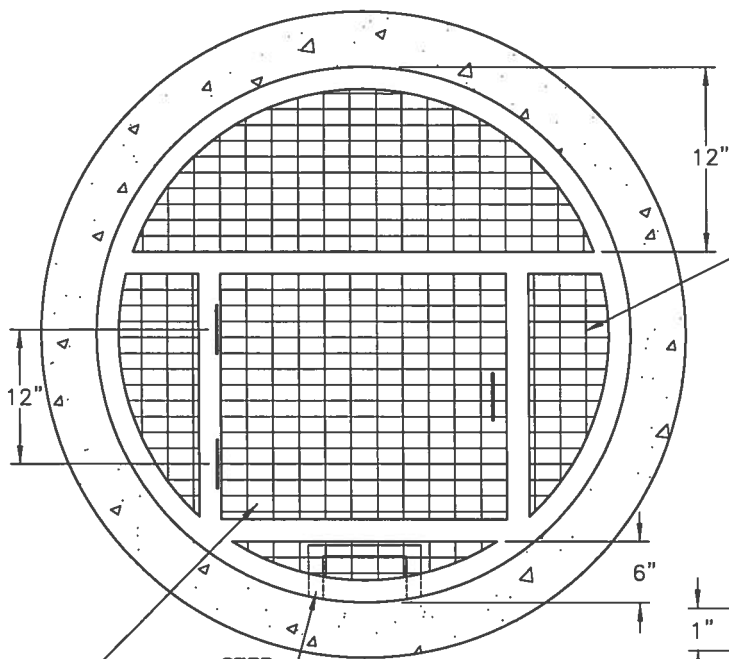

24"x30" ACCESS DOOR WITH RECESSED HANDLE AND WALL FASTENER

PLATFORM  
DETAIL

ANCHOR GRATING TO "L"s WITH 3/8" BOLTS (PLATFORM IS TO BE REMOVABLE)

SUPPORT CHANNEL 3"x3"x3/8" GALVANIZED STEEL "L" ANCHORED WITH 8-1/2" STAINLESS STEEL BOLTS & RAMSETS INTO MH WALL.

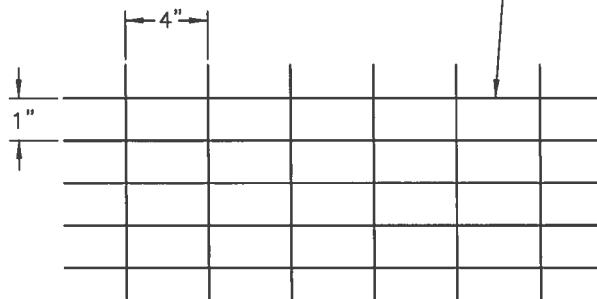
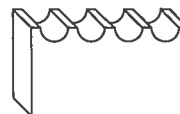

USE FIBERGLASS OR ALUMINUM SERRATED GRATING BEARING BARS 3/16"x1-1/4" HEAVY DUTY GENERAL USE

GRATE  
DETAIL

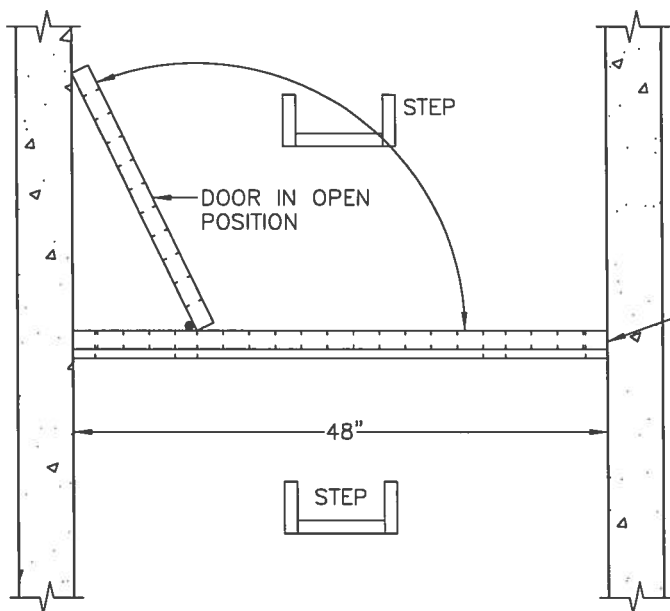

PLATFORM LOCATED AT THE MIDPOINT

ELEVATION

**NOTES**

- LANDING PLATFORMS SHALL ONLY BE PROVIDED AT LOCATIONS AS SPECIFIED ON APPROVED PROJECT DRAWINGS.

DRAFT STANDARDS UTIL - STD 106

1/25/12  
*Kevin Wegener* 2-6-12  
 CITY ENGINEER DATE  
*Chris Zytow* 2/7/12  
 AURORA WATER DATE

LANDING PLATFORM

106

# STANDARD

## TYPICAL STEEL ENCASEMENT CONSTRUCTION

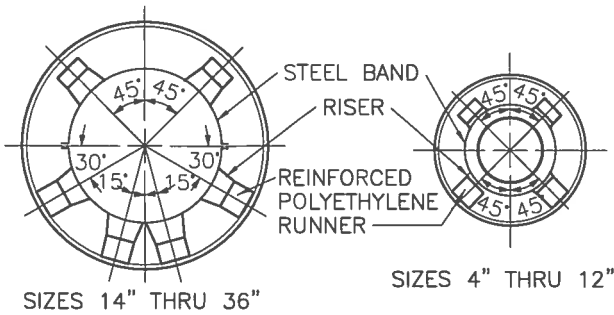

SIZES 14" THRU 36"

SIZES 4" THRU 12"

RUNNER CONFIGURATION

CARRIER PIPE NOMINAL DIA.	CASING PIPE	
	MIN. I.D.	MIN. WALL THICKNESS
4"	12"	0.250"
6"	16"	0.250"
8"	18"	0.282"
12"	23"	0.344"
16"	30"	0.406"
24"	40"	0.469"

CASING CHOCKS SHALL MEET OR EXCEED  
 PSI MODEL C8G-2 OR C12G-2  
 APS MODEL SI  
 POWERSEAL 4810  
 RESTRAINED CASING SPACER BY UNI-FLANGE

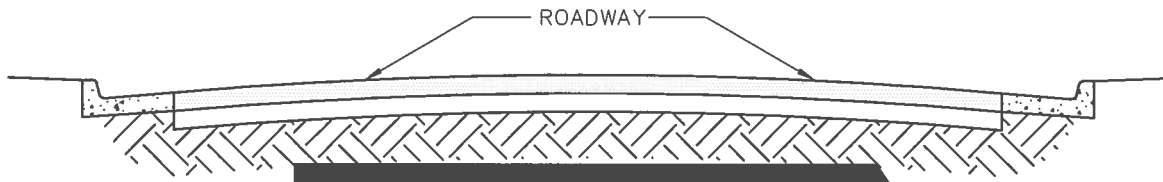

**STEEL CASING INFORMATION  
 REQUIRED ON CONSTRUCTION PLANS**

1. LENGTH AND TIES TO ENDS OF CASING
2. THICKNESS IN INCHES
3. INSIDE DIAMETER

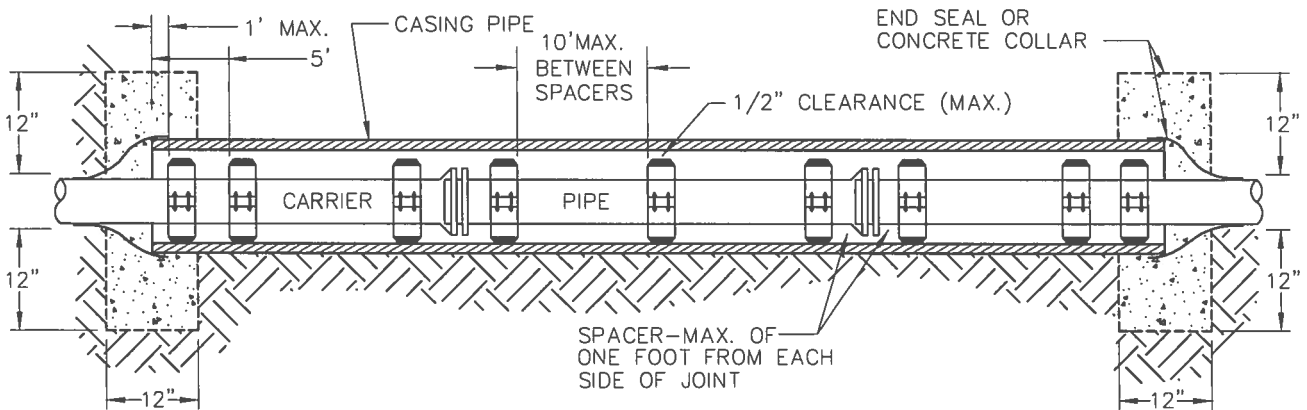

**NOTES**

1. JOINT RESTRAINT PIPE SHALL BE USED FOR CARRIER PIPE THROUGH ALL BORES. P.V.C.(A.S.T.M.-D3034-SDR 35) MAY BE USED FOR SANITARY SEWERS ON BORES OF 100' OR LESS IN LENGTH. DUCTILE IRON PIPE SHALL BE POLYWRAPPED.
2. IF THE BORE IS NOT CONSTRUCTED TO THE PROPER GRADE AN ADDITIONAL MANHOLE SHALL BE INSTALLED AT THE GRADE CHANGE.
3. THE CASING SHALL BE SEALED WITH CONCRETE COLLARS OR ENDSEALS. NO SPIRAL WELDED STEEL CASING PIPE SHALL BE USED.
4. THE PIPE AND CASING SHALL BE INSULATED BY USE OF CASING CHOCKS. ALL POLYETHYLENE CHOCKS ARE NOT ALLOWED.
5. STEEL CASING SHALL BE POLY WRAPPED OR FACTORY COATED FOR DIRECT BURY APPLICATIONS. 48 lb ANODES SHALL BE INSTALLED AT BOTH ENDS OF CASING FOR BORED APPLICATIONS.

DRAFT STANDARDS UTIL - STD 107

*Kevin Wegener* 2-6-12  
 CITY ENGINEER DATE

*Chris J. G. Jr.* 2/7/12  
 AURORA WATER DATE

**TYPICAL STEEL  
 ENCASEMENT  
 CONSTRUCTION**

# STANDARD

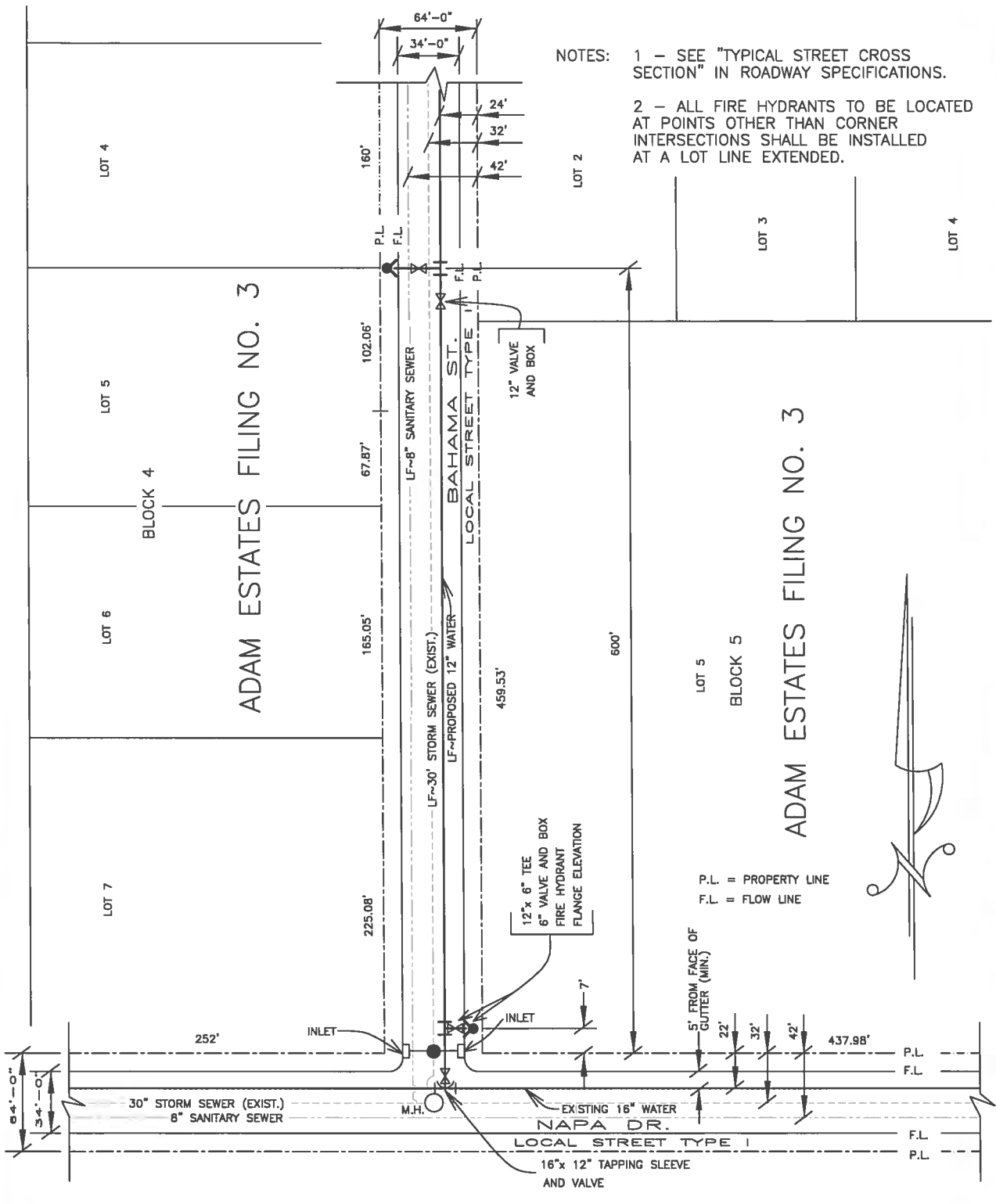

- NOTES:
- 1 - SEE "TYPICAL STREET CROSS SECTION" IN ROADWAY SPECIFICATIONS.
  - 2 - ALL FIRE HYDRANTS TO BE LOCATED AT POINTS OTHER THAN CORNER INTERSECTIONS SHALL BE INSTALLED AT A LOT LINE EXTENDED.

P.L. = PROPERTY LINE  
F.L. = FLOW LINE

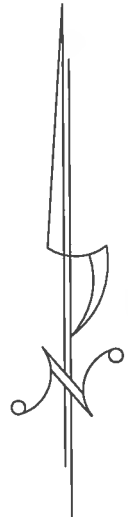

DRAFT STANDARDS VLN-STD\108

1/23/12  
*Kevin Wegman* 2-6-12  
 CITY ENGINEER DATE  
*Chris Ste* 2/7/12  
 AURORA WATER DATE

DISTRIBUTION SYSTEM  
TYPICAL PLAN

108

STANDARD

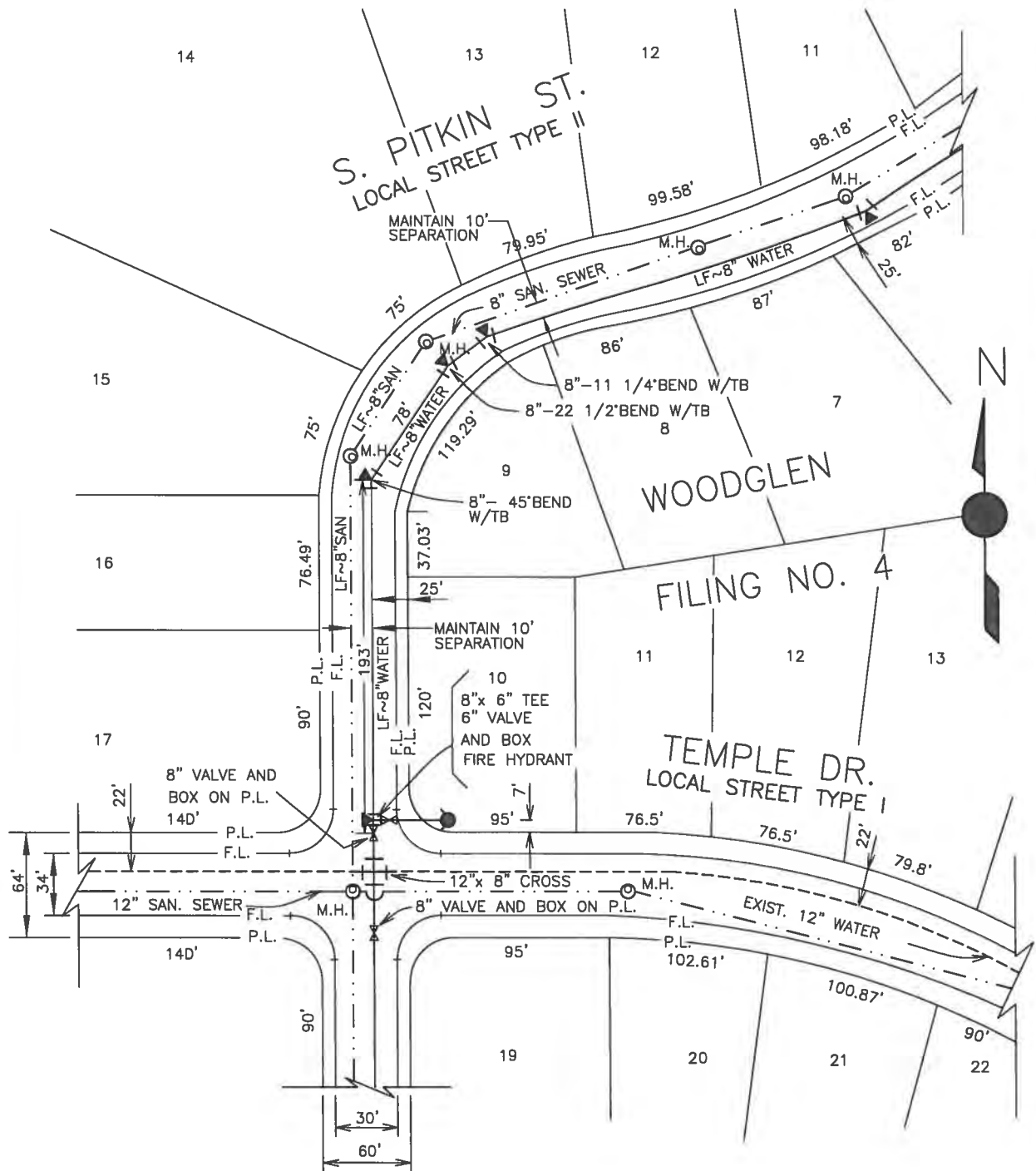

NOTE: CURVILINEAR WATERLINE IS NOT PERMITTED.

DRAFT STANDARDS UTIL - STD 108

*1/22/12*  
*Kevin W. Jensen* 2-6-12  
 CITY ENGINEER DATE  
*Chris J. Galt* 2/7/12  
 AURORA WATER DATE

DISTRIBUTION SYSTEM  
 TYPICAL PLAN  
 FOR CURVED STREETS

109



# STANDARD

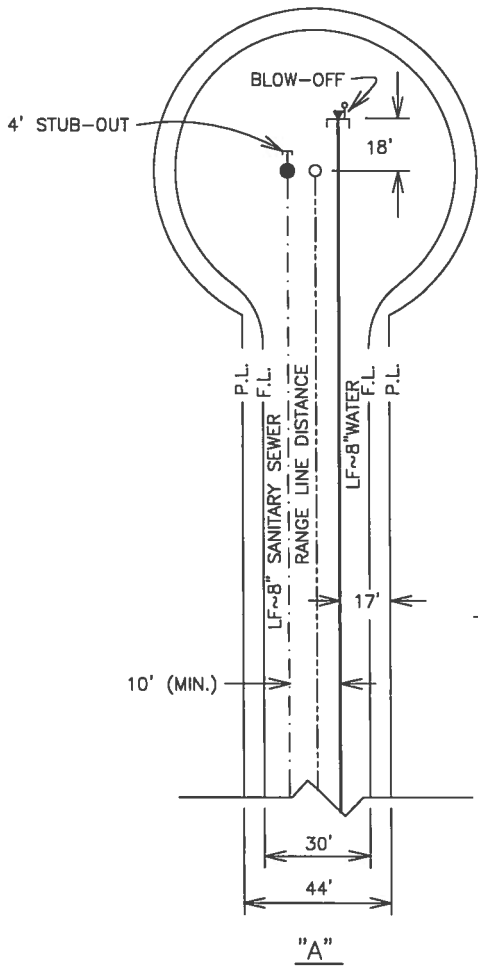

**"A" - STRAIGHT LINE CUL-DE-SAC:**  
 LAY WATER PIPE TO 18' BEYOND THE CENTER (RADIUS POINT) OF CUL-DE-SAC.

**"B" - OFFSET CUL-DE-SAC:**  
 LAY WATER PIPE TO 5' BEYOND P.I. THEN TO 18' BEYOND CENTER (RADIUS POINT) OF CUL-DE-SAC.

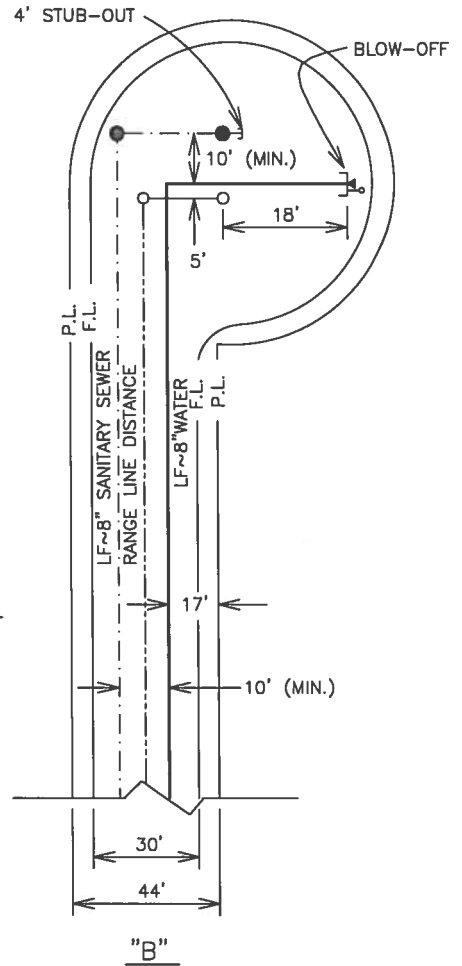

LOCAL STREET TYPE 2 ALTERNATIVE

**NOTE:**

1. RESIDENTIAL CUL-DE-SAC LESS THAN 250' IN LENGTH SEE C.O.A. ROADWAY SPECIFICATIONS FOR TYPICAL STREET CROSS SECTIONS.

DRAFT STANDARDS UTIL - STD 110

<i>Kevin Weger</i> CITY ENGINEER	2-6-12 DATE
<i>Chris G...</i> AURORA WATER	2/7/12 DATE

**DISTRIBUTION SYSTEM  
 TYPICAL PLAN  
 FOR CUL-DE-SACS**

**110**

STANDARD

PROCEDURES TO BE FOLLOWED BY THE CONTRACTOR FOR CONSTRUCTION OF WATER METERS

CALL WATER ENGINEERING INSPECTIONS AT 303-739-7385 BEFORE 3:30pm 24 HOURS PRIOR TO TAPPING THE MAIN FOR INSPECTION OF TAPS 2" AND SMALLER. CITY PERFORMS TAPS FOR 3" AND LARGER METERS-ALL EXCAVATION SUBJECT TO BACK SLOPING OR SHORING AND PROVIDE 18" OF CLEARANCE AROUND MAIN. CALL OPERATIONS SERVICE CENTER AT 303-326-8645 TO SCHEDULE TAPS FOR 3" AND LARGER.



CONTRACTOR INSTALLS METER PIT AND SERVICES LINE FROM METER PIT TO BUILDING. CALL WATER ENGINEERING INSPECTIONS AT 303-739-7385 PRIOR TO METER PIT INSTALLATION.



INSPECTION BY AURORA WATER ENGINEERING

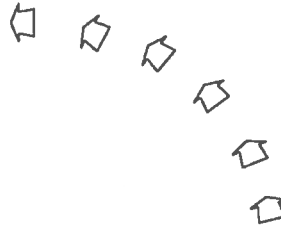

CONTRACTOR MUST MAKE REPAIRS BEFORE RE-SCHEDULING.



CALL OPERATIONS SERVICE CENTER FOR METER SETTING BY 3:30pm FOR NEXT DAY INSTALLATION @ 303 326-8080.



CUSTOMER SERVICE WILL INSTALL METER UPON ACCEPTANCE OF METER PIT OR VAULT. IF REJECTED, A NOTICE OF DISCREPENCY WILL BE LEFT NEXT TO THE BUILDING PERMIT, IN VAULT, OR WITH CONSTRUCTION SUPERINTENDANT.



CONTRACTOR MUST MAKE FINAL REPAIRS BEFORE RE-SCHEDULING. REINSPECTION FEE WILL BE ASSESSED FOR EACH RE-INSPECTION.



METER SET

NO SERVICE PROVIDED, IF CURB AND GUTTER IS NON-EXISTING OR NOT IN PLACE, UNLESS LETTER OF RESPONSIBILITY WITH SIGNATURE IS SENT TO WATER T&D SUPERINTENDENT REQUIRING THE OWNER/DEVELOPER TO ADJUST THE GRADE OF THE PIT, YOKE OR LATERAL, IF NECESSARY.

DRAFT STANDARD UTIL-STD-200

1/25/12 Kim W. Jensen 2-6-12 CITY ENGINEER DATE
Chris 2/7/12 2/7/12 AURORA WATER DATE

METER INSTALLATION PROCEDURE

200

# STANDARD

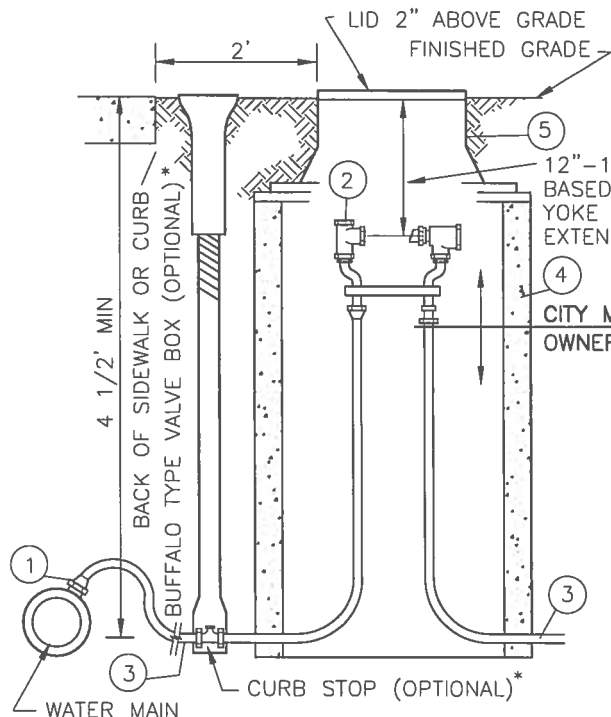

**DESCRIPTION:**

1. CORPORATION STOP AND INSULATOR – FURNISHED AND INSTALLED BY DEVELOPER AND POLYWRAPPED ACCORDING TO DIPRA SPECIFICATIONS.
2. LOCKING SHUT OFF VALVE.
3. SERVICE LINE – COPPER TUBING (TYPE "K")
4. METER PIT: 24" I.D. x 28" O.D. x 4' IN ONE FOOT SECTIONS.
5. METER PIT HOOD (SEE DETAIL 202).

CITY MAINTENANCE  
OWNER MAINTENANCE

**NOTES:**

1. WATER METER FURNISHED AND INSTALLED BY AURORA WATER.
2. SERVICE LINE MUST HAVE A MINIMUM COVER OF 4 1/2 FEET.
3. METER PIT MUST BE AT LEAST 2' FROM ANY HARDSCAPE.
4. CALL WATER ENGINEERING INSPECTIONS AT 303-739-8833 FOR WATER SERVICE LINE INSPECTIONS PRIOR TO BACKFILLING.
- \* 5. VALVE BOX AND CURB STOP ARE OPTIONAL FOR RESIDENTIAL – MANDATORY FOR COMMERCIAL, IRRIGATION, AND ALL SERVICES TAPPED OFF 16" MAINS AND LARGER. CURB STOP SHALL NOT BE LOCATED IN STREET, GUTTER OR SIDEWALK.
6. ALL METER PITS SHALL BE STAKED FOR FINISHED GRADE IF INSTALLATION PRECEDED CONSTRUCTION OF ADJACENT CURB OR SIDEWALK. IF CURB AND GUTTER IS NOT IN PLACE OR REQUIRED, A LETTER OF RESPONSIBILITY SHALL BE SENT TO THE C.O.A. WATER T&D SUPERINTENDENT, REQUIRING THE OWNER/DEVELOPER TO ADJUST THE GRADE OF THE PIT, YOKE OR LATERAL IF NECESSARY. CONTACT OPERATIONS SERVICE CENTER @ (303) 326-8080 FOR INFORMATION.
7. METER SETTER MUST HAVE INTEGRAL OUTLET SPRING CHECK VALVE.

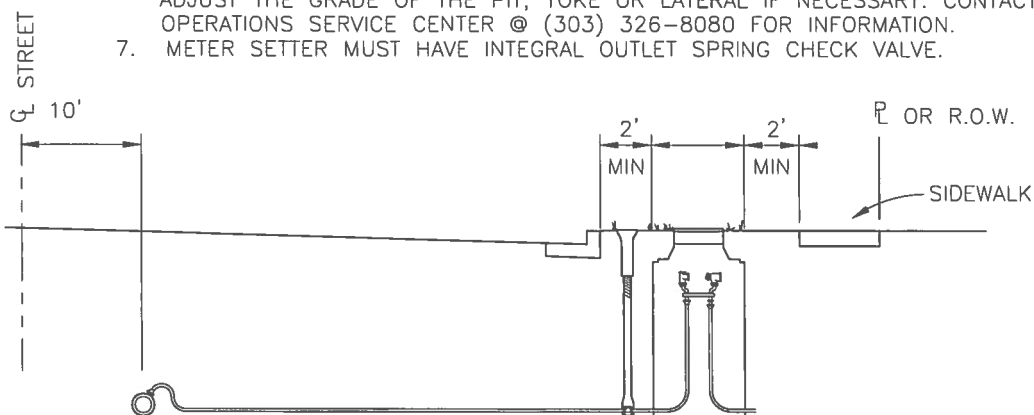

DRAFT STANDARD\UTL-STD\201

<i>1/23/12</i> Kevin Wegener CITY ENGINEER	2-6-12 DATE
Clay Zschar AURORA WATER	2/7/12 DATE

**METER INSTALLATION**  
**3/4" & 1" SERVICE**

**201**

STANDARD

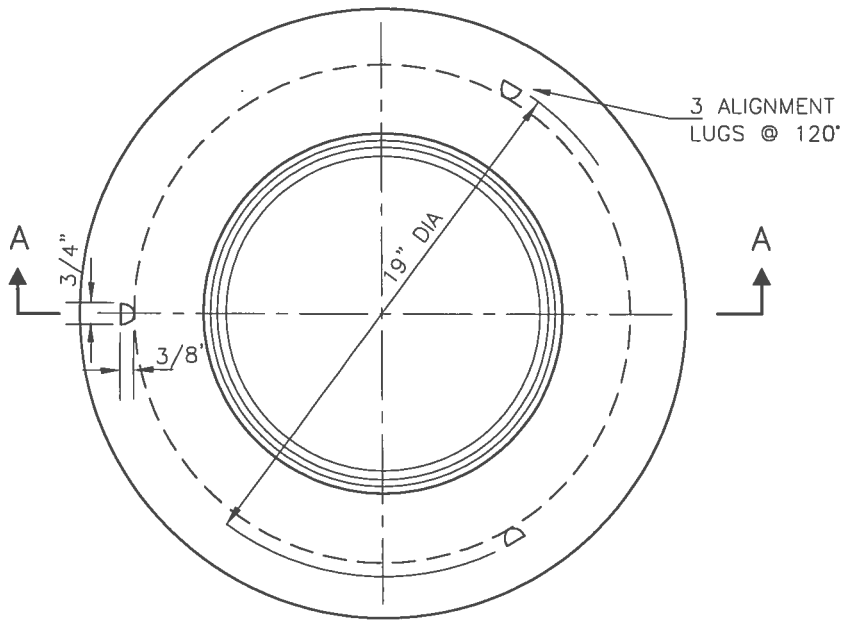

PIT COVER

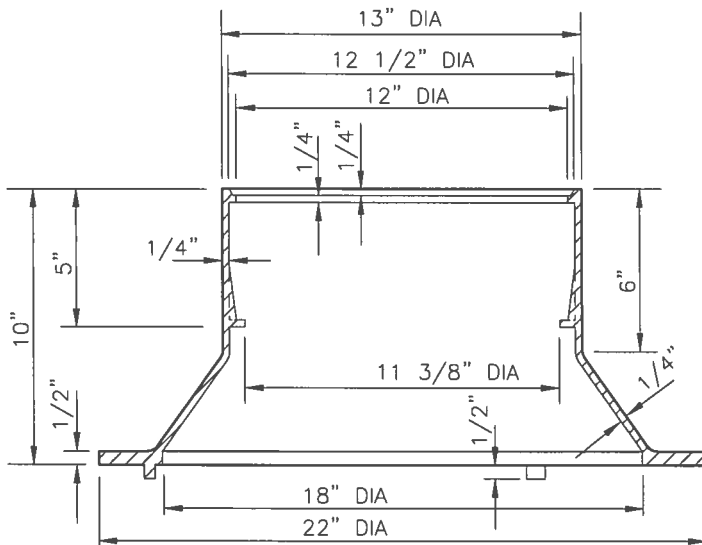

SECTION A-A

NOTES:

1. WATER METER PIT HOOD LIDS SHALL HAVE A 2" (51mm) HOLE PREDRILLED IN THE CENTER OF LID.
2. THE LIDS SHALL BE CAST IRON.
3. THE HOOD MAY BE CAST IRON OR ALUMINUM.

DRAFT STANDARDS UTIL - STD 202-1

1/23/12  
 Kevin Weyner 2-6-12  
 CITY ENGINEER DATE  
 Chris 2/7/12  
 AURORA WATER DATE

METER PIT COVER

1 of 2  
 202

# STANDARD

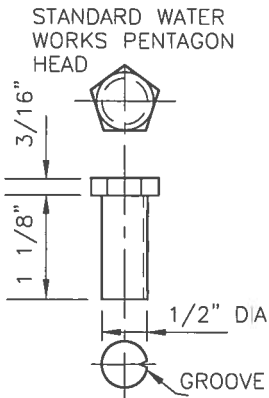

**BOLT DETAIL**

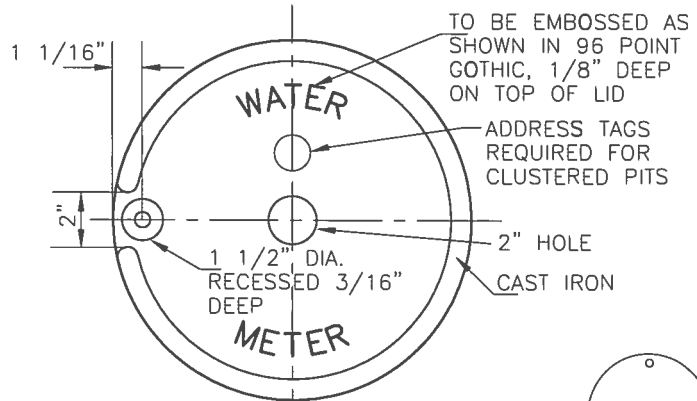
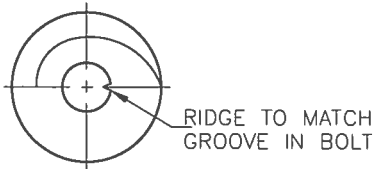

**LID - TOP VIEW**



1 3/4" BRASS TAG WITH HOLE TO SECURE TO LID

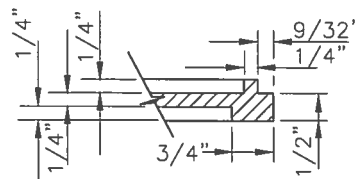

**SECTION D-D**

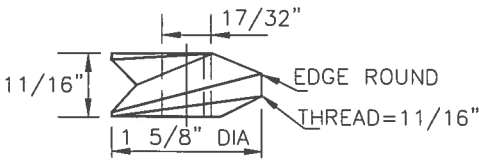

**WORM SCREW DETAIL**

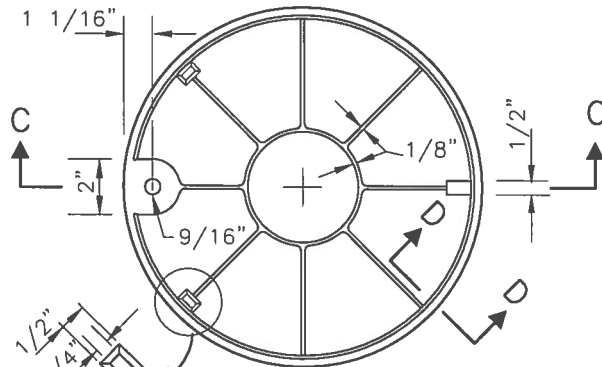

**LID - BOTTOM VIEW**

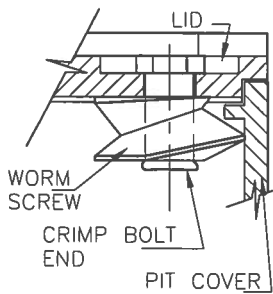

**ASSEMBLY DETAIL**

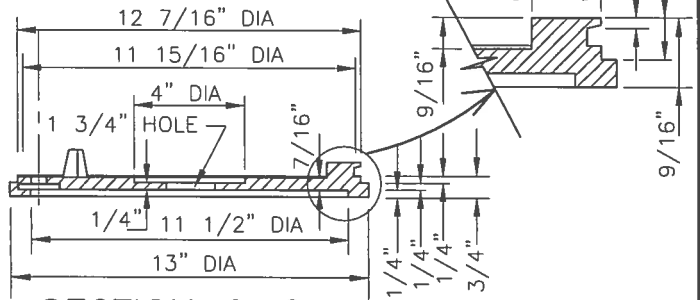
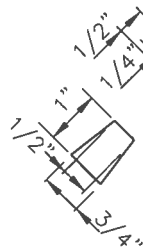

**SECTION C-C**

DRAFT STANDARDS UTIL - STD 202-2

*Kevin Wegener* 2-6-12  
 CITY ENGINEER DATE  
*Chris J. Ar* 2/7/12  
 AURORA WATER DATE

**METER INSTALLATION  
3/4" MASTER SERVICE**

2 of 2  
**202**

# STANDARD

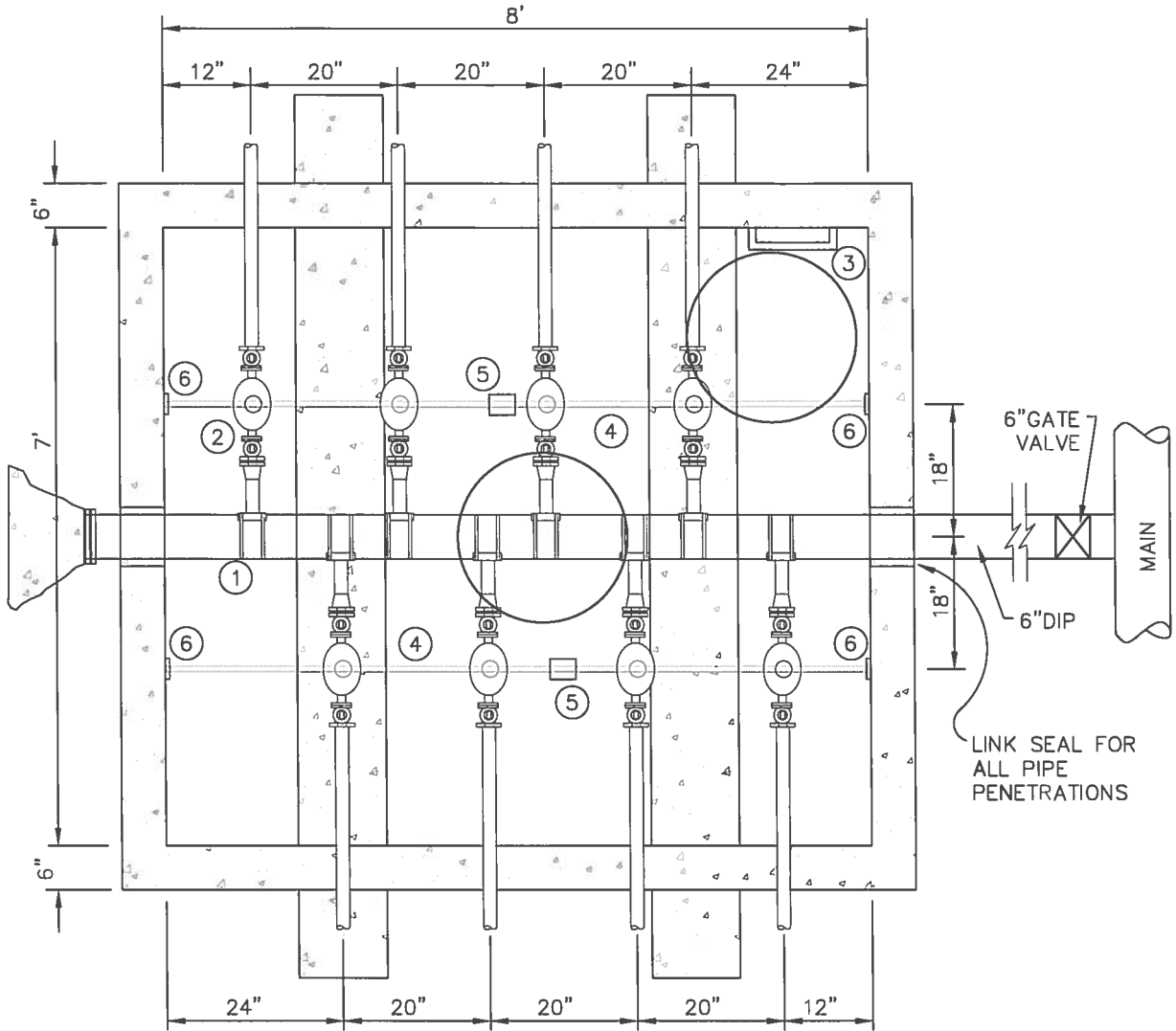

**DESCRIPTION:**

1.  $\frac{3}{4}$ "x6" DOUBLE STRAP TAPPING SADDLE
2. FORD COPPERSETTER II VBH72-15W-22-33 OR APPROVED EQUAL.
3. MANHOLE STEPS PER DETAIL 105
4.  $\frac{3}{4}$ " GALVANIZED PIPE
5.  $\frac{3}{4}$ " GALVANIZED UNION
6. GALVANIZED MOUNTING FLANGE WITH  $\frac{1}{4}$ " STAINLESS STEEL ANCHOR SCREWS
7. NEENAH FROST PROOF LID #r1758E OR APPROVED EQUAL
8.  $\frac{1}{4}$ "x23  $\frac{3}{4}$ " ALUMINUM AMR MOUNTING PLATE PER DETAIL A
9. STANDARD MANWAY ACCESS FOR METER VAULTS - DETAIL 207

**NOTES:**

- A. DETAIL ONLY TO BE USED WITH THE EXPRESS CONSENT OF AURORA WATER ENGINEERING - CONTRACT ENGINEERING INSPECTIONS FOR PRE-CONSTRUCTION CONSULTATION
- B. WATER METERS FURNISHED & INSTALLED BY AURORA WATER.
- C. FOOTERS REQUIRED IN ALL CASES UNDER VAULT.
- D. LIDS MUST BE 2" ABOVE FINISH GRADE.
- E. TOP STEP TO BE 12"-24" BELOW SURFACE. STEPS TO BE 12" APART VERTICALLY.
- F. ADDRESS TAGS REQUIRED ON METER SETTERS & SERVICE LINE STUB OUTS.

DRAFT STANDARDS UNIT - STD 203-1

<i>1/23/12</i> <i>Kim Wegner</i>	2-6-12
CITY ENGINEER	DATE
<i>Chris J. [Signature]</i>	2/7/12
AURORA WATER	DATE

**MULTI-METER  
VAULT**

1 of 2  
**203**

# STANDARD

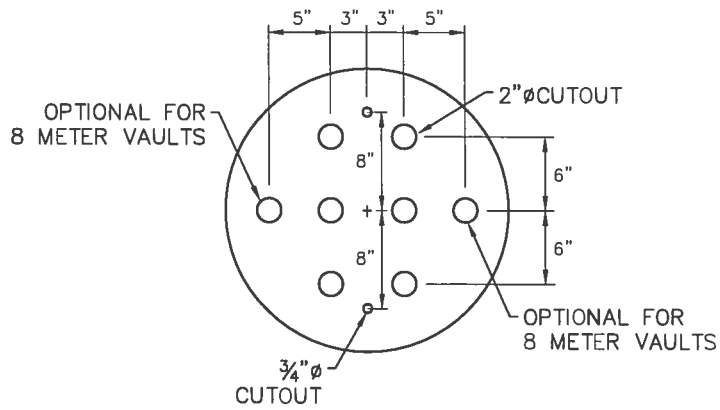
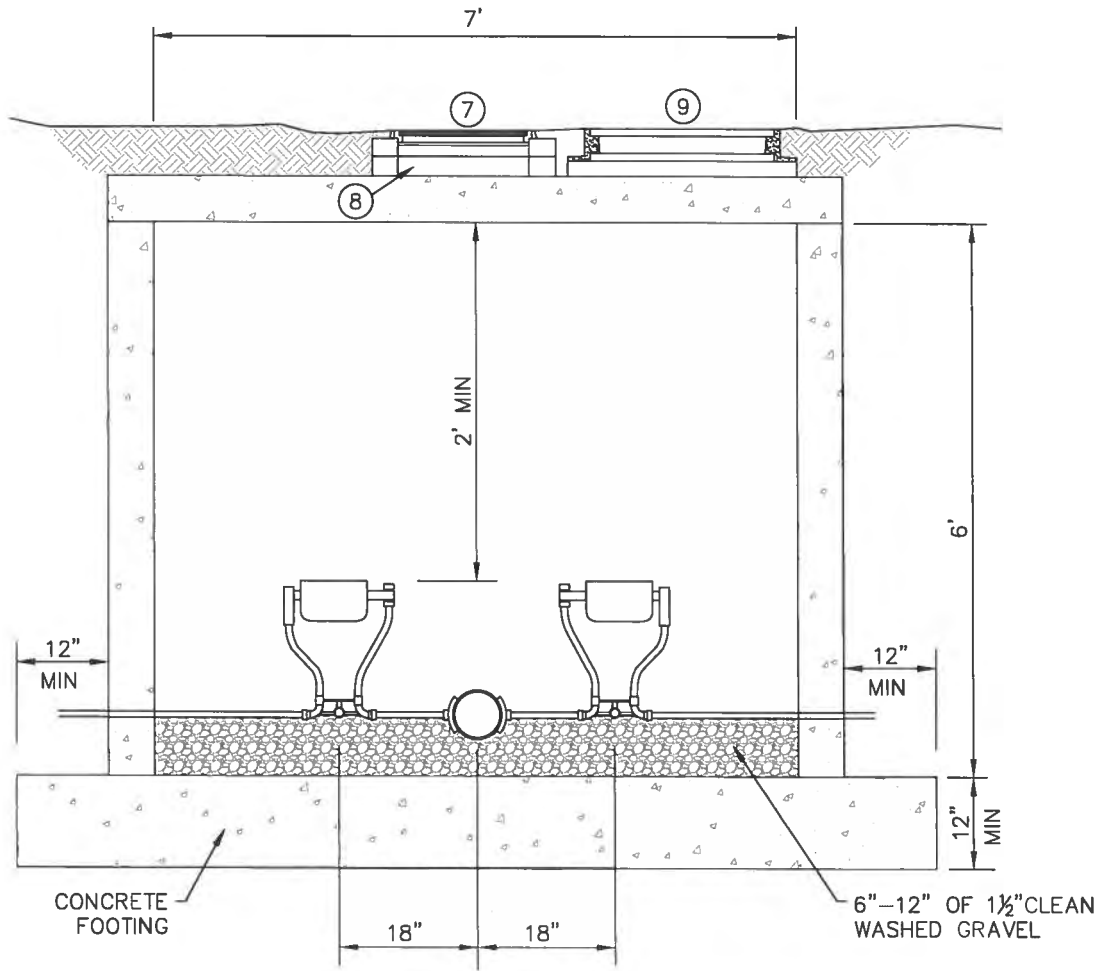

DETAIL A

DRAFT STANDARDS UTIL - STD V003-2

<i>2/23/12</i> CITY ENGINEER _____ AURORA WATER	2-6-12 DATE _____ DATE
--	---------------------------------

MULTI-METER  
VAULT

2 of 2  
**203**

# STANDARD

## NOTES:

1. WATER METER FURNISHED AND INSTALLED BY AURORA WATER.
2. SERVICE LINE MUST HAVE A MINIMUM COVER OF 4-1/2 FEET.
3. WATER ENGINEERING INSPECTIONS WILL INSPECT THE SERVICE LINE PRIOR TO BACK-FILLING.
4. NO JUMPERS ARE ALLOWED IN IRR. METERS THAT DO NOT UTILIZE THE OUTLET CHECK VALVE. ALL CONSTRUCTION SOURCES SHOULD BE DOWNSTREAM OF THE OUTLET CHECK VALVE. CONTRACTORS SHALL BE RESPONSIBLE FOR ANY CHANGES OR DAMAGES DUE TO SHUT-OFF.
5. CONCRETE SHALL NOT BE LAID IN FLOOR OF METER PIT.
6. FOOTINGS ARE TO BE INSTALLED UNDER METER PIT.
7. FIELD SOLDERED JOINTS OR PLASTIC PIPE NOT ALLOWED IN METER PIT.
8. IRRIGATION METERS REQUIRE RP DEVICE.

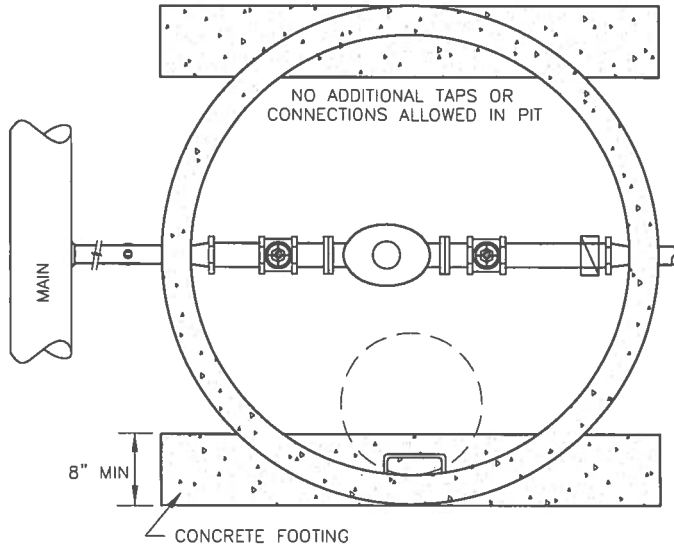

**PLAN**

MAXIMUM OF 2-2" ADJUSTMENT RINGS. THICKER ADJUSTMENT RINGS CLOSES TO MANHOLE LID. RAMNEK BETWEEN ALL SURFACES OF MANHOLE LID AND RING AND COVER.

## MATERIALS:

1. CORPORATION STOP AND INSULATING COUPLING
2. SWING CHECK VALVE ON OUTLET REQUIRED.
3. WATER SERVICE LINE - COPPER TUBING, (TYPE K) - 4 1/2' MIN. COVER.
4. WATER METER.
5. BALL VALVES-CLASS 125 CONNECTED WITH LOK-PAK TYPE COUPLING TEE HEAD WITH LOCK WINGS.
6. RING AND COVER - 24" NEENAH R-1706-1, WEIGHT 224 LBS. OR EQUAL, WITH "CITY OF AURORA WATER" CAST INTO THE LID. (DETAIL 206)
7. PRECAST 60" MANHOLE - ASTM C-478 WITH MANHOLE STEPS, OFFSET FLAT TOP AND CONCRETE ADJUSTMENT RINGS.
8. COPPER TO BRASS FITTINGS MUST BE EXPOSED.
9. FLARE COUPLING ON INLET SIDE OF METER MUST BE EXPOSED.
10. CALL 303-326-8080 FOR DIMENSION.
11. FOR 1 1/2", USE FORD B-11-666W FIP X FIP OR MEULLER 300 BALL VALVES WITH LOCK WINGS.
12. FOR 2", USE FORD B-11-777W FIP X FIP OR MEULLER 300 BALL VALVES WITH LOCK WINGS.

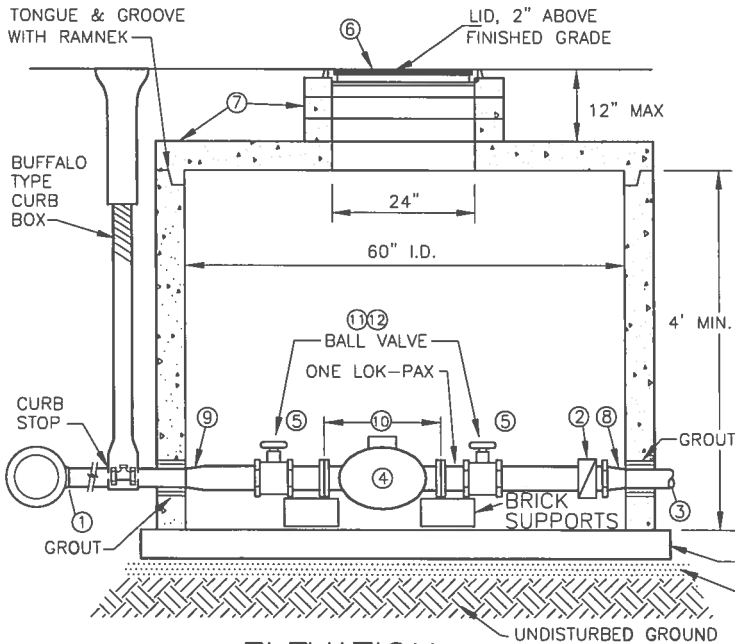

**ELEVATION**

### LAY LENGTHS (INCLUDING GASKETS)

- 1 1/2" = 13 1/4"  
2" = 10 1/4"

DRAFT STANDARDS UTIL - STD 204-1

1/25/12  
*Kevin Wegener* 2-6-12  
 CITY ENGINEER DATE  
*Chris J. Str* 2/7/12  
 AURORA WATER DATE

**1 1/2" DISC & 2" TURBINE  
 IRRIGATION METER  
 VAULT INSTALLATION**

1 of 2  
**204**



# STANDARD

## NOTES:

1. WATER METER FURNISHED AND INSTALLED BY AURORA WATER.
2. SERVICE LINE MUST HAVE A MINIMUM COVER OF 4-1/2 FEET.
3. WATER ENGINEERING INSPECTIONS WILL INSPECT THE SERVICE LINE PRIOR TO BACK-FILLING.
4. NO JUMPERS ARE ALLOWED IN IRR. METERS CONTRACTORS SHALL BE RESPONSIBLE FOR ANY CHANGES OR DAMAGES DUE TO SHUT-OFF.
5. CONCRETE SHALL NOT BE LAID IN FLOOR OF METER PIT.
6. FOOTINGS ARE TO BE INSTALLED UNDER METER PIT.
7. FIELD SOLDERED JOINTS OR PLASTIC PIPE NOT ALLOWED.
8. IRRIGATION METERS REQUIRE RP DEVICE.
9. 1 1/2" TO 2" IRRIGATION METERS REFER TO 204.

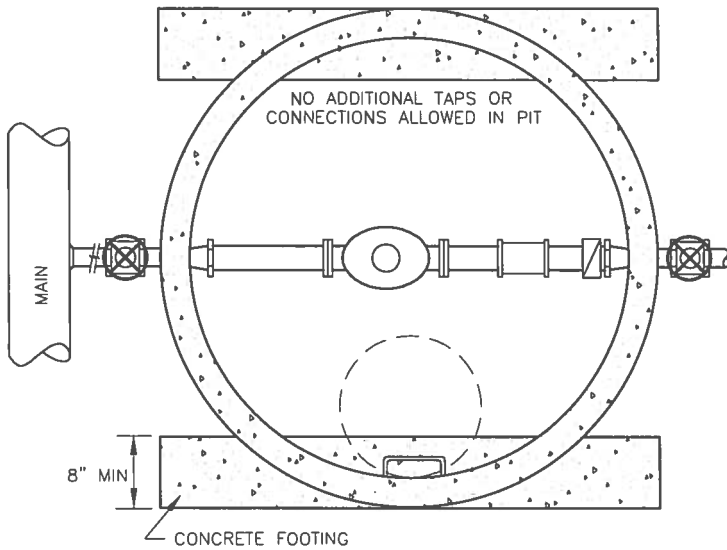

PLAN

MAXIMUM OF 2-2" ADJUSTMENT RINGS. THICKER ADJUSTMENT RINGS CLOSETS TO MANHOLE LID. REMNEK BETWEEN ALL SURFACES OF MANHOLE LID AND RING AND COVER.

## MATERIALS:

1. TAPPING TEE AND VALVE FURNISHED AND INSTALLED BY AURORA WATER. (TEE IN LEIU OF TAPPING SLEEVE ALLOWED IF NEW MAIN IS BEING CONSTRUCTED.)
2. RESILIENT SEAT GATE VALVE WITH MEGA-LUG JOINT RESTRAINT. (4" MINIMUM)
3. WATER SERVICE LINE - DUCTILE IRON, (CLASS 52) - 4 1/2' MIN. COVER.
4. WATER METER.
5. DRESSER STYLE MECHANICAL COUPLING.
6. RING AND COVER - 24" NEENAH R-1706-1, WEIGHT 230 LBS. OR EQUAL, WITH "WATER" CAST INTO THE LID. (OETAIL 207)
7. PRECAST 60" MANHOLE 5' HIGH - ASTM C-478 WITH MANHOLE STEPS, OFFSET FLAT TOP AND CONCRETE ADJUSTMENT RINGS.

\* CALL 303-326-8645 FOR DIMENSION.

### LAY LENGTH (INCLUDING GASKETS)

3" = 12 1/4"  
4" = 14 1/4"

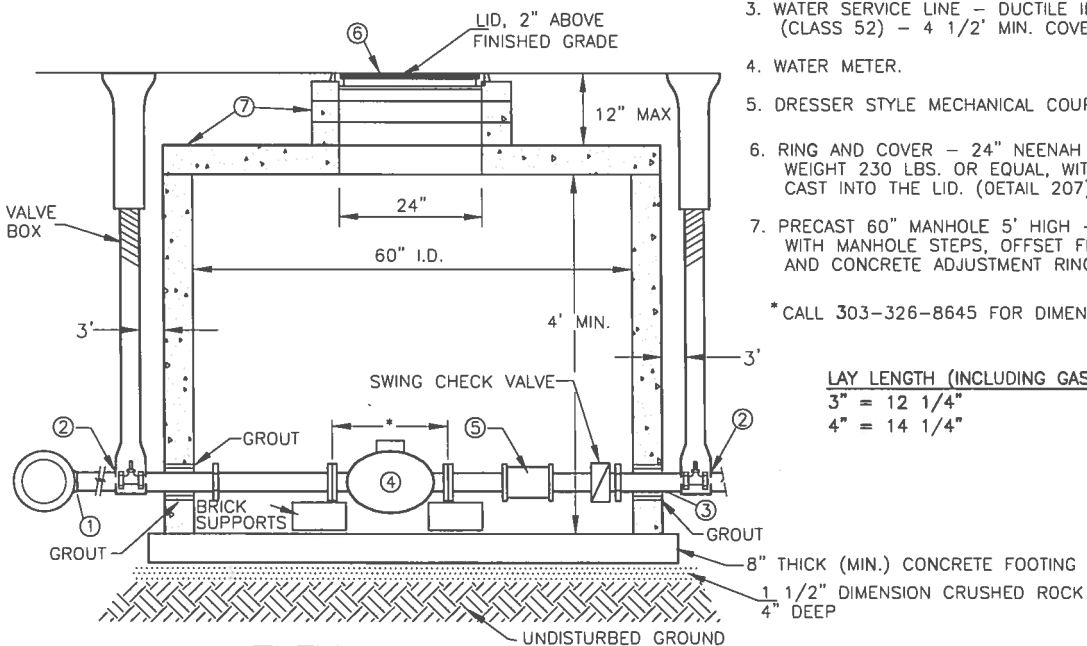

ELEVATION

DRAFT STANDARDS UTIL - STD 204-2

11/25/12  
*Kevin Wegener* 2-6-12  
 CITY ENGINEER DATE  
*Chris Z...* 2/7/12  
 AURORA WATER DATE

**3" & 4" TURBINE  
 IRRIGATION METER  
 VAULT INSTALLATION**

2 of 2  
**204**

# STANDARD

**NOTES:**

1. IF THE SURFACE IS NOT TO FINAL GRADE AT THE TIME OF THE METER INSTALLATION, THE OWNER SHALL RAISE OR LOWER THE PIT TO MATCH THE FINAL GRADE.
2. METER PIT AND RELATED SERVICE UNIT MUST BE INSPECTED BY AURORA WATER ENGINEERING INSPECTIONS PRIOR TO BACKFILLING.

3. NO CONCRETE TO BE LAID IN FLOOR OF METER PIT.
4. FOOTINGS TO BE INSTALLED UNDER METER PIT.
5. FIELD SOLDERED JOINTS OR PLASTIC PIPE NOT ALLOWED IN PIT.
6. WATER ENGINEERING INSPECTIONS SHALL INSPECT THE SERVICE LINE PRIOR TO BACKFILLING.
7. FOOTERS OPTIONAL IN LANDSCAPE.

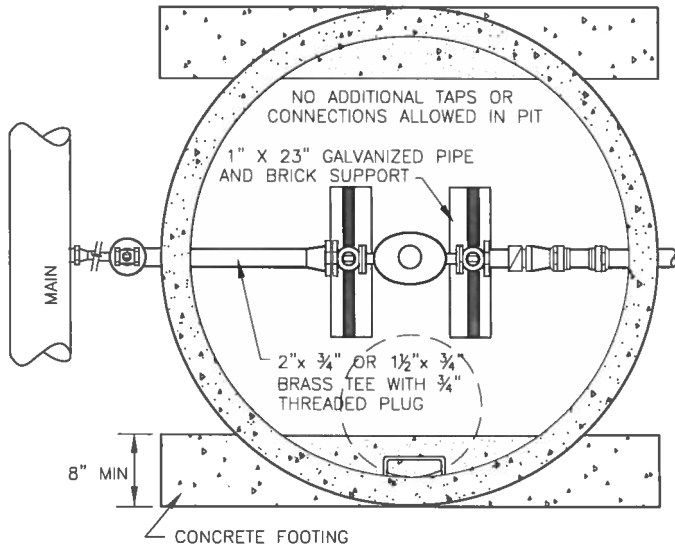

**PLAN**

MAXIMUM OF 2-2" ADJUSTMENT RINGS. THICKER ADJUSTMENT RINGS CLOSES TO MANHOLE LID. RAMMEK BETWEEN ALL SURFACES OF MANHOLE LID AND RING AND COVER.

**MATERIALS:**

1. CORPORATION STOP AND INSULATING COUPLING - FURNISHED AND INSTALLED BY THE CONTRACTOR.
2. SWING CHECK VALVE ON OUTLET REQUIRED.
3. WATER SERVICE LINE - COPPER TUBING, TYPE 'K' - 4' MIN. COVER.
4. METER - FURNISHED AND INSTALLED BY AURORA WATER.
5. RING AND COVER - 24" NEENAH R-1706-1, OR EQUAL, 224 LBS., WITH "CITY OF AURORA WATER" CAST INTO THE LID. (DETAIL 207)
6. PRECAST 60" MANHOLE - ASTM C-478 WITH MANHOLE STEPS, OFFSET FLAT TOP AND CONCRETE ADJUSTMENT RINGS.
7. COPPER TO BRASS COMPRESSION FITTINGS (MUST BE EXPOSED).
8. FLARE COUPLING ON INLET SIDE OF METER (MUST BE EXPOSED).
9. BYPASS VALVE WITH WINGED LOCKING VALVE.
10. CALL (303)326-8645 FOR DIMENSIONS.
11. BALL VALVES WITH LOCK WINGS.

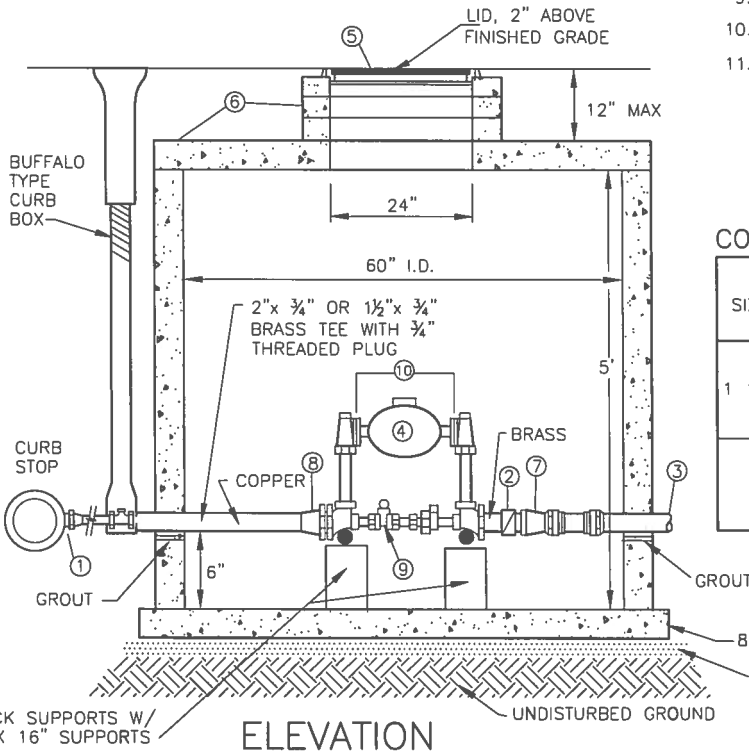

**ELEVATION**

**COPPER METER YOKES WITH BY-PASS**

SIZE	FORD	MUELLER	AY McDONALDS
1 1/2"	VBB76-12B-11-66	B2423 (12" HT)	20B612 WWFF 665
2"	VBB77 12B	B2423 (12" HT)	20B712 WWFF 775

LAY LENGTH (INCLUDING GASKETS)  
 1 1/2" = 13 1/4"  
 2" = 17 1/4"

DRAFT STANDARDS UTIL - STD 208

1/23/12  
*Kevin Wegener* 2-6-12  
 CITY ENGINEER DATE  
*Chris Z...* 2/7/12  
 AURORA WATER DATE

**1 1/2" & 2" DISC METER  
 CUSTOM SETTER INSTALLATION  
 FOR DOMESTIC SERVICE**

**205**

# STANDARD

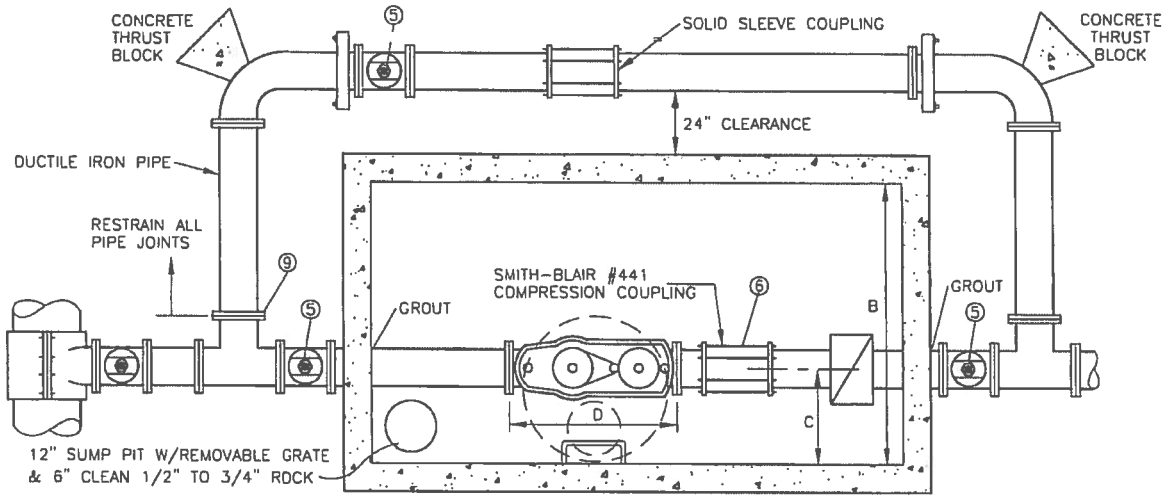

MAXIMUM OF 2-2" ADJUSTMENT RINGS. THICKER ADJUSTMENT RINGS CLOSEST TO MANHOLE LID. RAMNEK BETWEEN ALL SURFACES OF MANHOLE LID AND RING AND COVER.

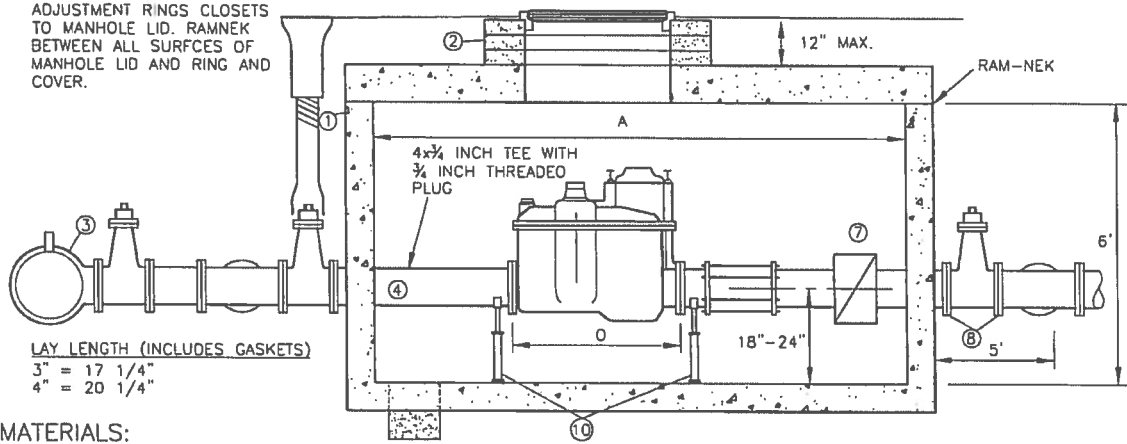

LAY LENGTH (INCLUDES GASKETS)  
 3" = 17 1/4"  
 4" = 20 1/4"

**MATERIALS:**

1. VAULT-WALL THICKNESS 6", FLOOR THICKNESS 6".
2. 36" RING & COVER W/ REMOVABLE LID, NEENAH R-1741-D, WEIGHT 351LBS. OR EQUAL. "WATER CAST INTO LID. (DETAIL 207)
3. TAPPING TEE & VALVE FURNISHED AND INSTALLED BY THE CITY OF AURORA WATER. (TEE IN MAIN IN LIEU OF TAPPING SLEEVE ALLOWED IF NEW MAIN IS BEING CONSTRUCTED.)
4. ALL PIPING SHALL BE DUCTILE IRON CONFORMING TO AWWA-C151.
5. RESILIENT SEAT GATE VALVES (4" MIN.) & VALVE BOX TO BE USED. CLASS 150 CONFORMING TO AWWA-C500.
6. COUPLING SHALL BE COMPRESSION TYPE SMITH-BLAIR, DRESSER OR EQUAL.
7. SWING CHECK VALVE FULLY ENCLOSED REQUIRED.
8. FLANGED OR COMPRESSION TYPE FITTINGS ONLY IN METER PIT.
9. BYPASS LINE SHALL BE THE SAME DIAMETER AS THE SERVICE LINE.
10. PIPE STANDS

A**	B**	C**	D
72"	48"	20 1/2"	*

\* CALL (303) 326-8645 FOR DIMENSIONS  
 \*\* MINIMUM DIMENSIONS

**NOTES:**

1. TOP STEP TO BE 18"-24" BELOW SURFACE. MANHOLE STEPS TO BE SPACED 12" APART VERTICALLY.
2. WATER ENGINEERING INSPECTIONS SHALL INSPECT THE SERVICE LINE PRIOR TO BACKFILLING.
3. METER FURNISHED & INSTALLED BY AURORA WATER.
4. 72" INSIDE DIAMETER VAULT IS AN ACCEPTABLE ALTERNATIVE. LID TO BE 2 INCHES ABOVE FINISHED GRADE.

DRAFT STANDARDS UNIT - STDY 208

*Ken Wegman* 2-6-12  
 CITY ENGINEER DATE  
*Chris Zytar* 2/7/12  
 AURORA WATER DATE

**METER VAULT INSTALLATION**  
**3" & 4" COMPOUND METER**  
**FOR DOMESTIC SERVICE**

206

# STANDARD

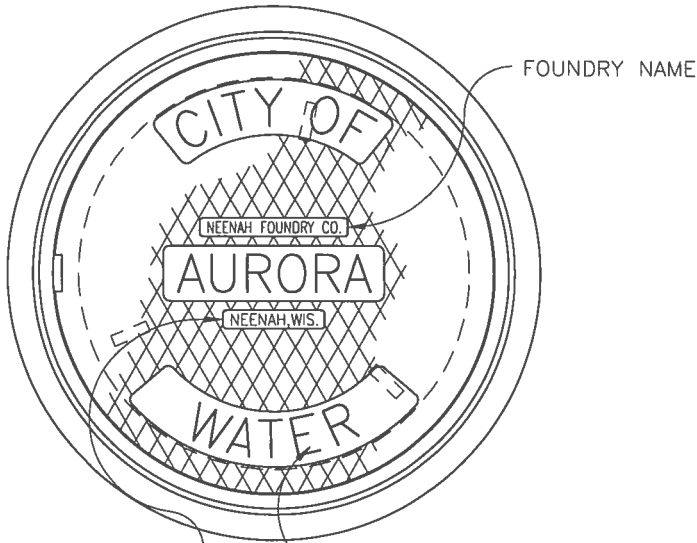

FOUNDRY NAME  
FOUNDRY LOCATION  
CITY, STATE  
2" TALL, FLUSH LETTERS

TOP VIEW

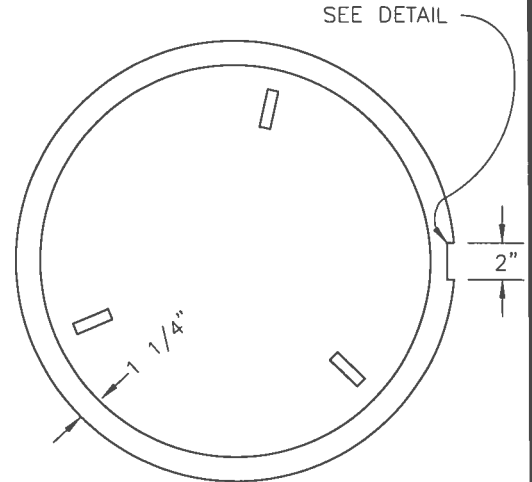

UNDERSIDE VIEW OF COVER

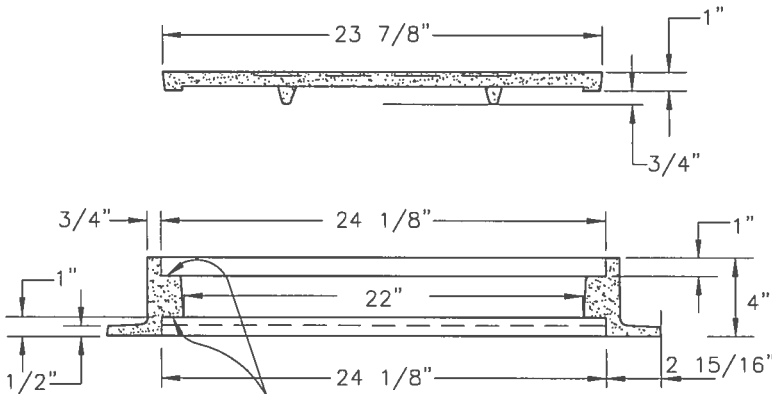

ALL BEARING SURFACES TO BE MACHINED

RING & COVER

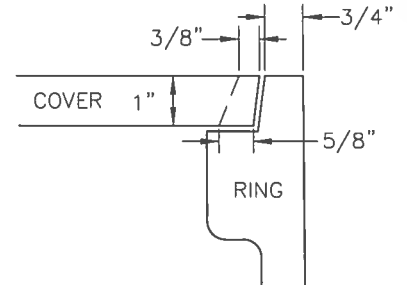

DETAIL-LIFTING NOTCH

NOTES:

1. A.S.T.M. DESIGNATION A-48-83 CLASS 25B (UNPAINTED).
2. ALL BEARING SURFACES TO BE MACHINED.
3. LETTERING ON COVER AS REQUIRED (WATER, SANITARY, OR STORM).
4. AURORA STANDARD-NEENAH R-1706, OR EQUAL, TOTAL MINIMUM WEIGHT APPROXIMATELY 224 LBS, MINIMUM FRAME WEIGHT -114 LBS, MINIMUM LID WEIGHT-110 LBS.
7. LIFTING NOTCH SHALL NOT EXTEND PAST INSIDE FACE OF RING SEAT.
6. SEE SECTION 10.00 FOR SPECIFICATIONS.

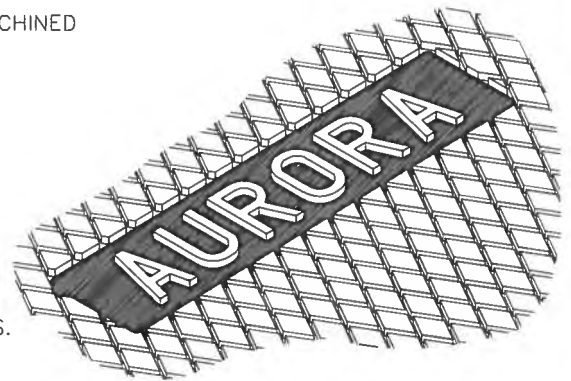

DETAIL-COVER DESIGN

TYPE "C" DESIGN: 1"X 1" SCORED 1/32"± DEEP

DRAFT STANDARDS UTIL - STD 207

*HW*  
*1/23/12*  
*Kevin Wilson* 2-6-12  
CITY ENGINEER DATE  
*Chris Z...* 2/7/12  
AURORA WATER DATE

24" WATER METER PIT  
RING & COVER

207

# STANDARD

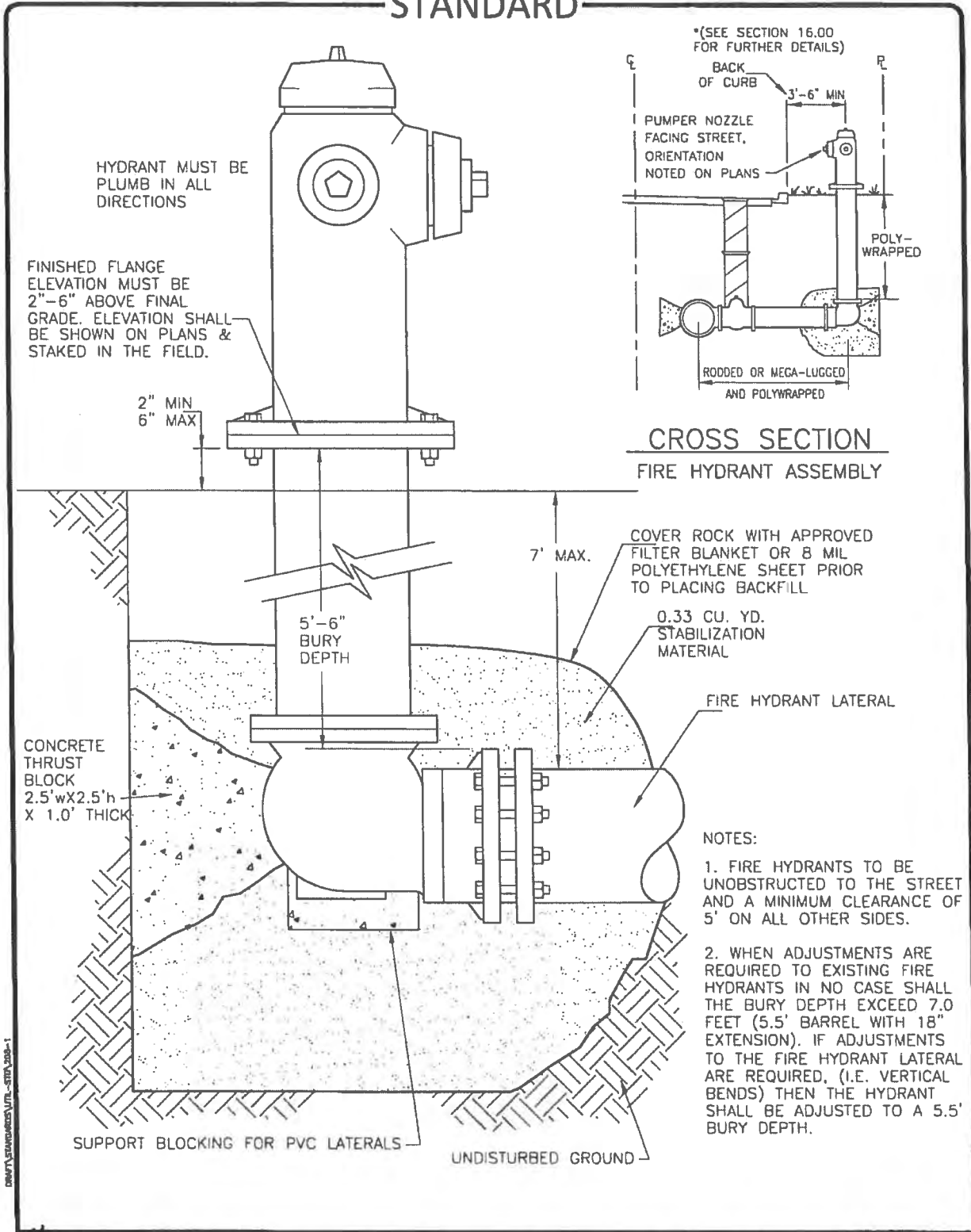

*KE*  
*1/23/12*  
*Kevin W. Wynn* 2-6-12  
 CITY ENGINEER DATE  
*Chris S. G. B.* 2/7/12  
 AURORA WATER DATE

**FIRE HYDRANT ASSEMBLY**

1 of 2  
**208**

# STANDARD

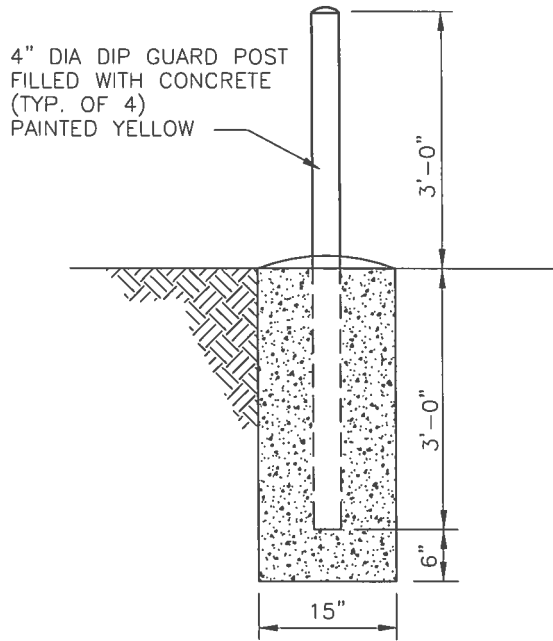
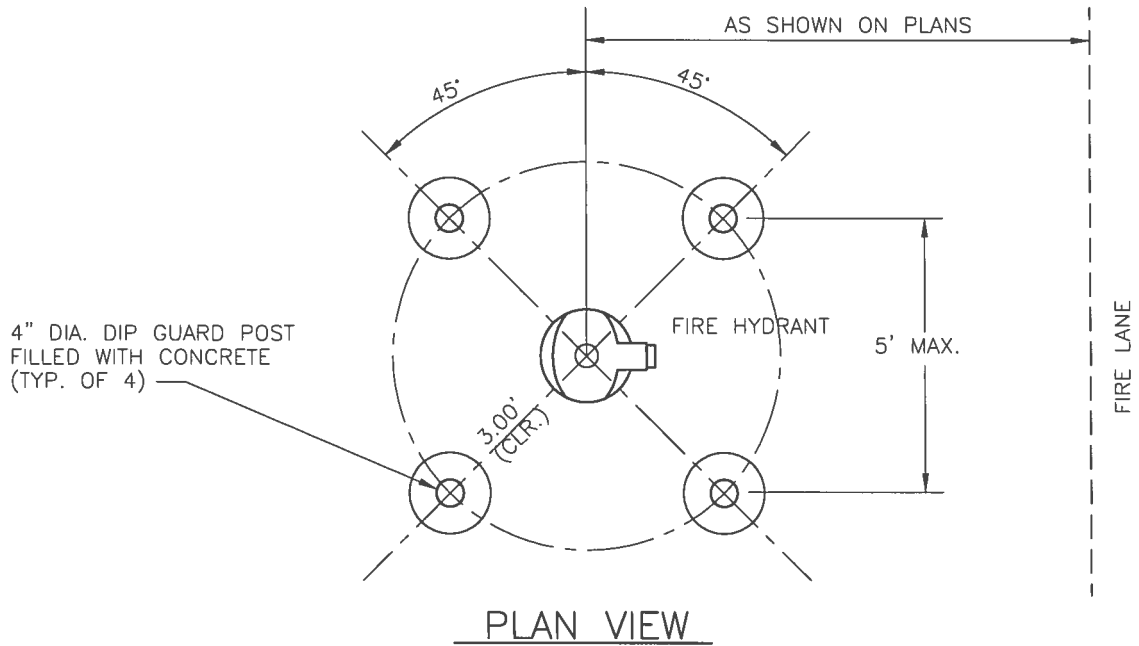

DRAFT\STANDARDS\UTL-STD\208-2

*AE*  
*2/23/12*  
*Karin Wegner* 2-6-12  
 CITY ENGINEER DATE  
*Chris J. Galt* 2/7/12  
 AURORA WATER DATE

FIRE HYDRANT  
 BOLLARDS

2 of 2  
 208

# STANDARD

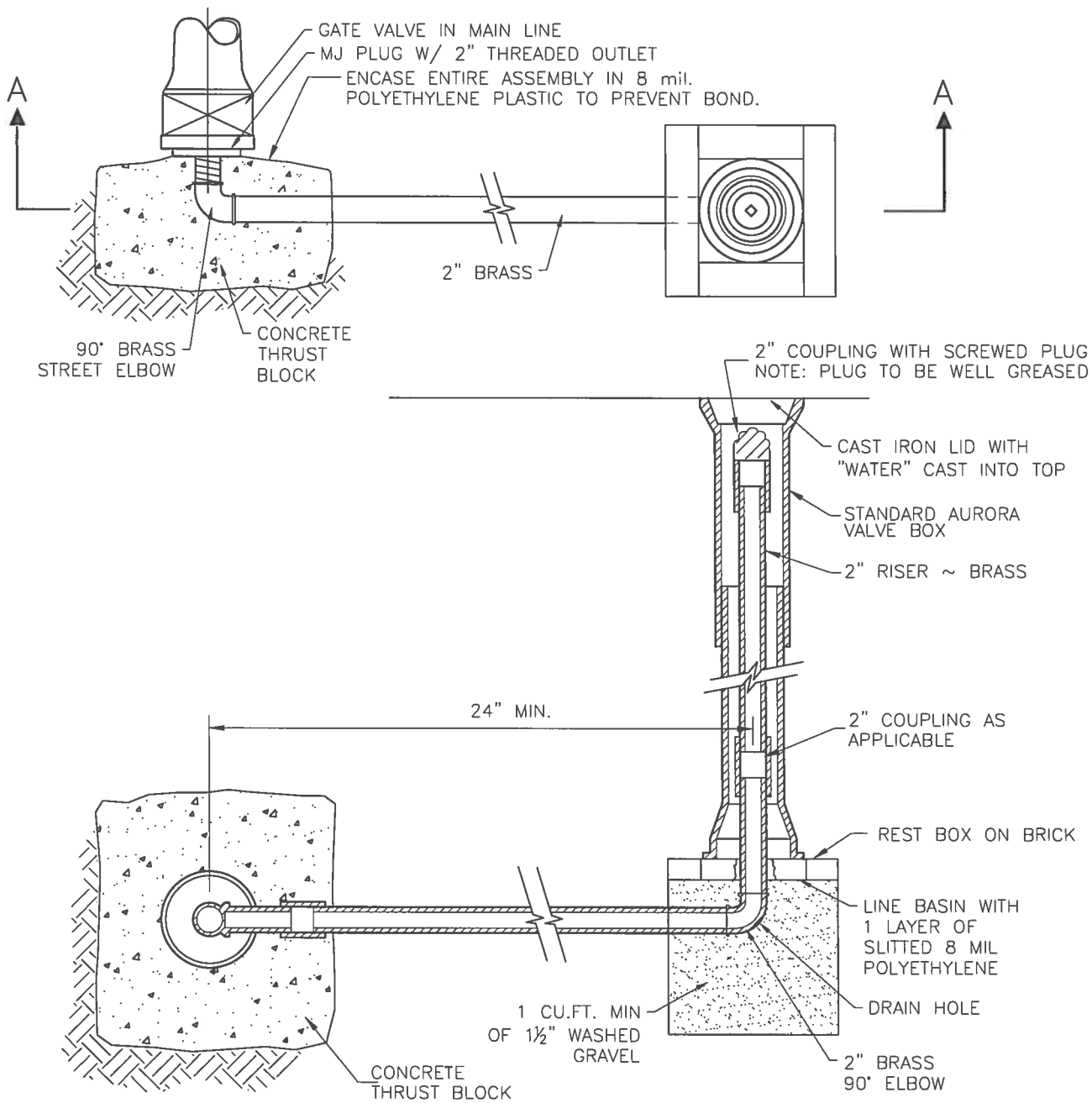

## SECTION A-A

NOTES:

1. ALL 2" PIPE & FITTINGS BE THREADED BRASS

DRAFT STANDARDS\UTIL-STD\209

<p><i>1/23/12</i> <i>Kim Wiegman</i> CITY ENGINEER</p> <p><i>Chris Zota</i> AURORA WATER</p>	<p>2-6-12 DATE</p> <p>2/7/12 DATE</p>
--	---

2" BLOWOFF DETAIL

209

# STANDARD

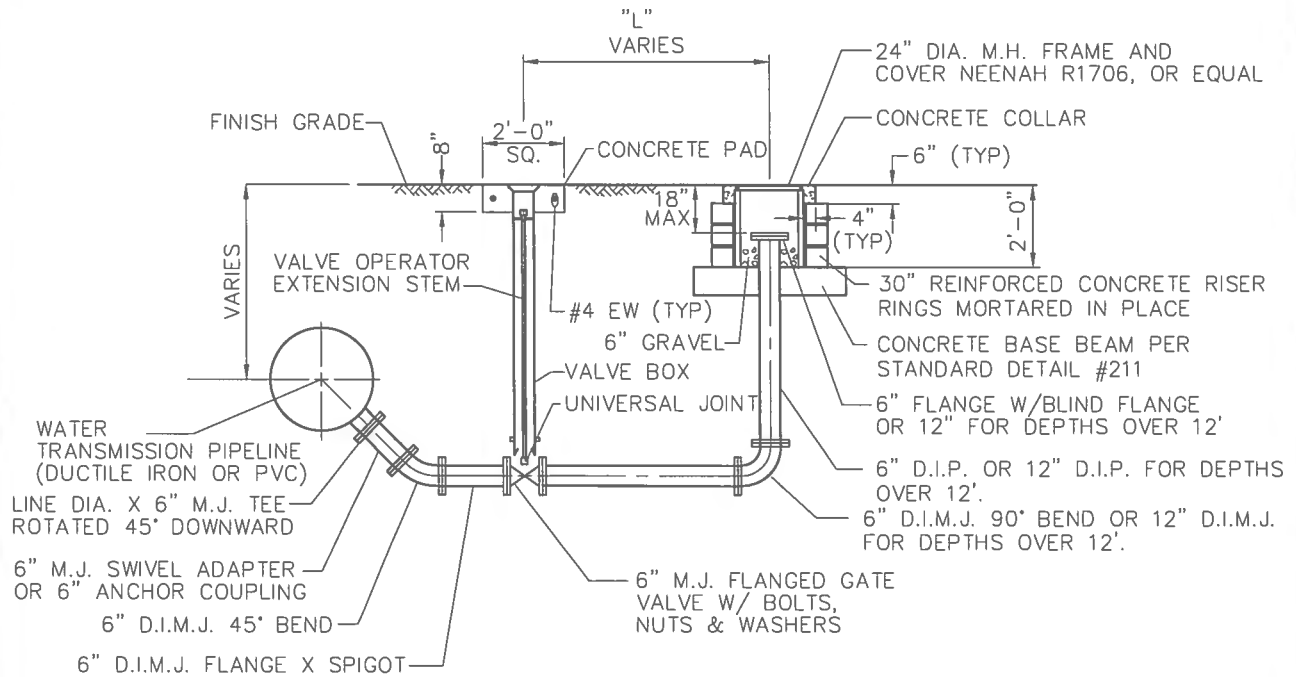

**NOTES:**

1. ALL BLOW-OFF PIPING SHOWN SHALL BE CLASS 52 D.I.P. AND POLYWRAPPED
2. REF. PLAN AND PROFILE SHEETS FOR BLOWOFF LOCATIONS AND ELEVATIONS.
3. MEG-A-LUG RESTRAINT IS REQUIRED FOR ALL PIPING.
4. CATHODIC PROTECTION SHALL BE PROVIDED BY ATTACHING A 17 lb. ANODE AND TEST SITE (32 LB. ANODE FOR RUNS EXCEEDING 50 FEET) TO THE 6" PIPING BETWEEN THE VALVE AND 90° BEND, PER DETAIL No. 219.
5. IF "L" IS GREATER THAN 20 FEET ON A D.I.P. MAIN, GATE VALVE MUST BE FLANGED WITH INSULATING FLANGE KIT.
6. IF DEPTH OF VALVE IS GREATER THAN OR EQUAL TO 12 FEET, REPLACE VALVE BOX WITH 6 INCH DIP.

DRAFT STANDARDS UTIL - STD 210-1

*1/23/12*  
*Kevin Wegener* 2-6-12  
 CITY ENGINEER DATE  
*Chris Z...* 2/7/12  
 AURORA WATER DATE

**6" BLOWOFF DETAIL**  
**(DUCTILE IRON OR PVC)**

1 of 2  
**210**



# STANDARD

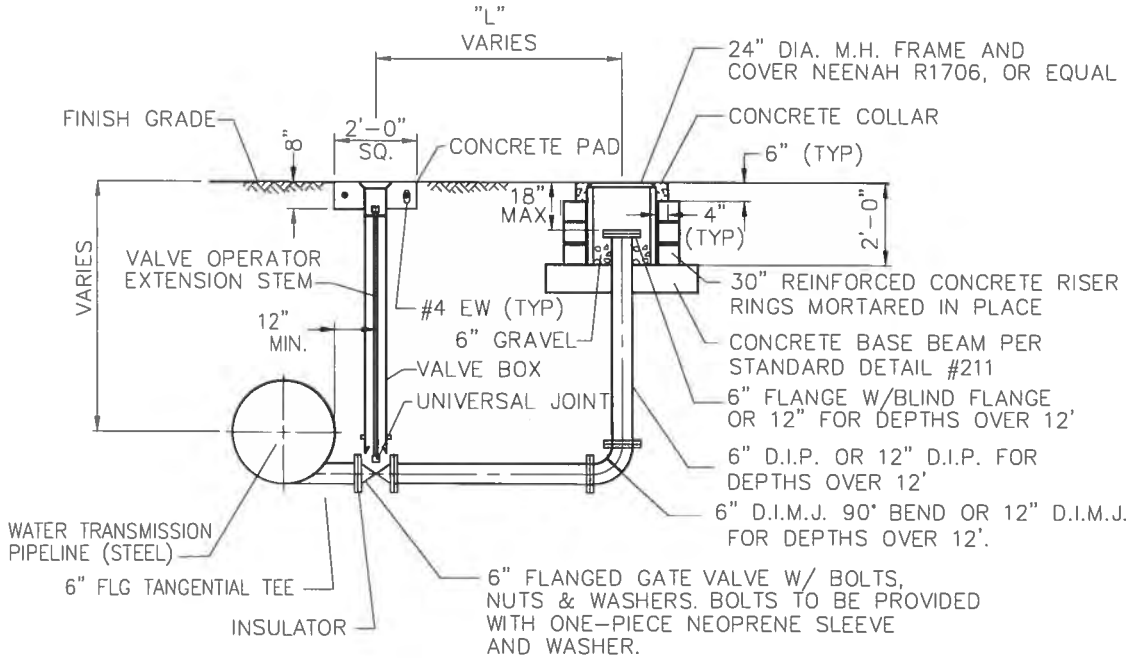

**Notes:**

1. ALL DUCTILE IRON PIPE SHOWN SHALL BE CLASS 52 AND POLYWRAPPED.
2. REF. PLAN AND PROFILE SHEETS FOR BLOWOFF LOCATIONS AND ELEVATIONS.
3. MEG-A-LUG RESTRAINT IS REQUIRED FOR ALL PIPING.
4. CATHODIC PROTECTION SHALL BE PROVIDED BY ATTACHING A 171b. ANODE AND TEST SITE (32 lb. ANODE FOR RUNS EXCEEDING 50 FEET) TO THE 6" PIPING BETWEEN THE VALVE AND 90° BEND PER DETAIL No. 219.
5. INSULATOR FLANGE BOLTS WILL BE EITHER STAINLESS STEEL #304 OR CORTEN.
6. WAX TAPE OR PETROLEUM TAPE AND PRIMER REQUIRED ON INSULATING FLANGE AND ALL BOLTS.

DRAFT STANDARDS VTL-STD\210-2

1/23/12 <i>Kevin Wegener</i> CITY ENGINEER	2-6-12 DATE
<i>Chris J. St...</i> AURORA WATER	2/7/12 DATE

**6" BLOWOFF DETAIL  
(STEEL)**

2 of 2

**210**

# STANDARD

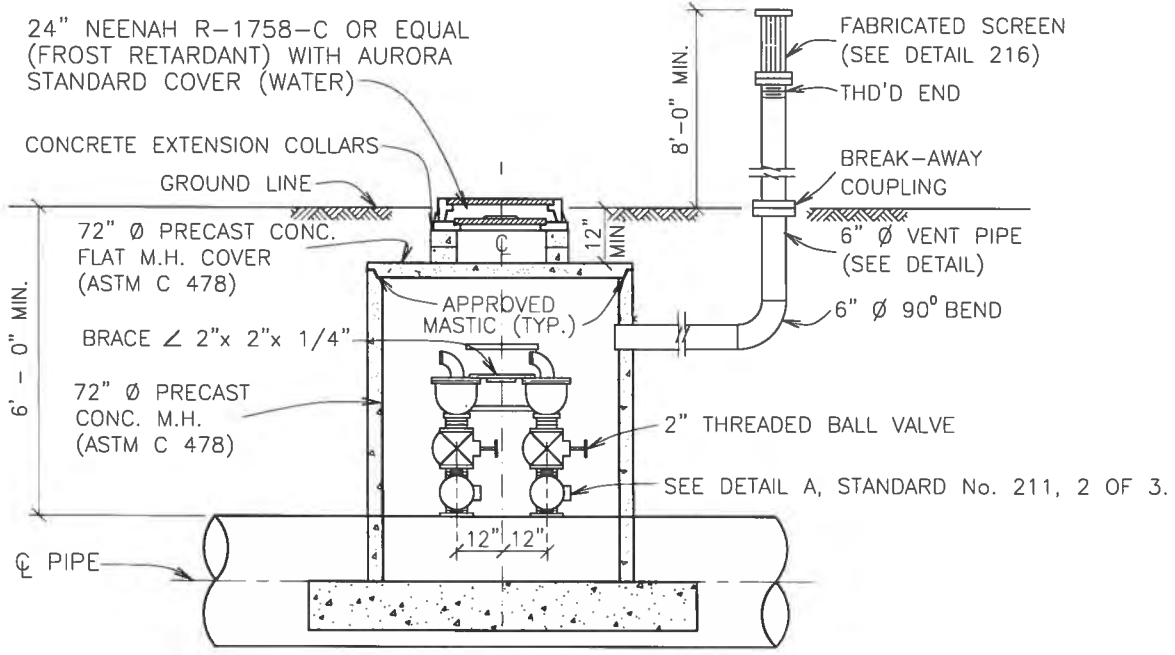

**SECTION A-A**

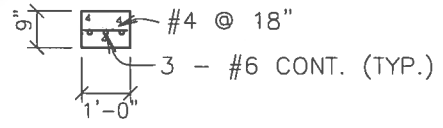

**FOOTING DETAIL**

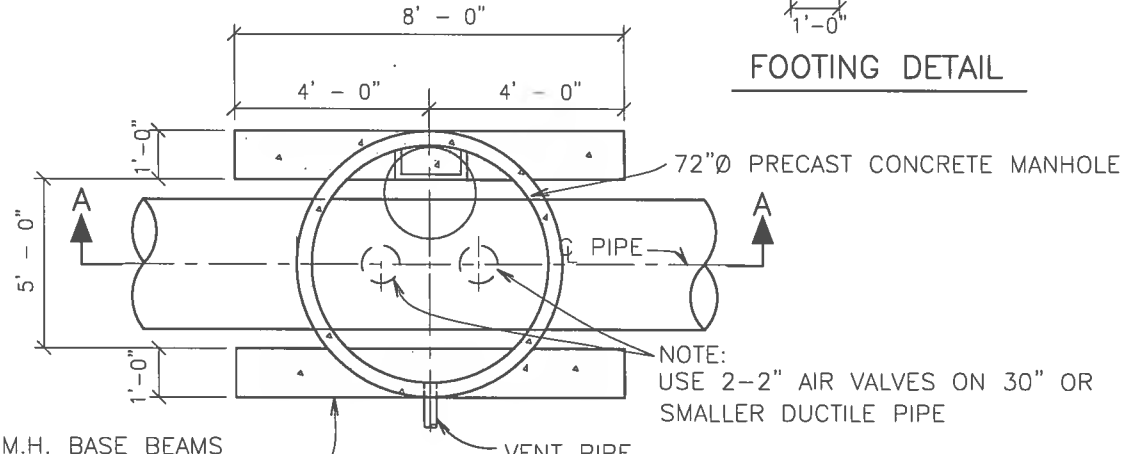

**PLAN**

**NOTES:**

1. TOP 6" IN VAULT SHALL BE CRUSHED ROCK.
2. THE DISTANCE BETWEEN RUNGS, CLEATS, AND STEPS SHALL NOT EXCEED 12 INCHES AND SHALL BE UNIFORM THROUGHOUT THE LENGTH OF THE LADDER.
3. LADDER RUNGS ARE REQUIRED IN PRECAST CONCRETE MANHOLES.
4. WELD ON STEEL WILL USE THREAD-O-LETS
5. INSTALL VENT PIPE OPPOSITE OF ACCESS OPENING.
6. TURN DISCHARGE PORT AWAY FROM VALVES AND ACCESS OPENING.
7. SEE SECTION 20.00 FOR COATING REQUIREMENTS.

DRAFT STANDARDS UTIL - STD 211-1

*KEW*  
*2/23/12*  
*Kevin Weger* 2-6-12  
 CITY ENGINEER DATE  
*Chris J. Str* 2/7/12  
 AURORA WATER DATE

**2" AIR VACUUM  
VALVE INSTALLATION**

1 of 3  
**211**

# STANDARD

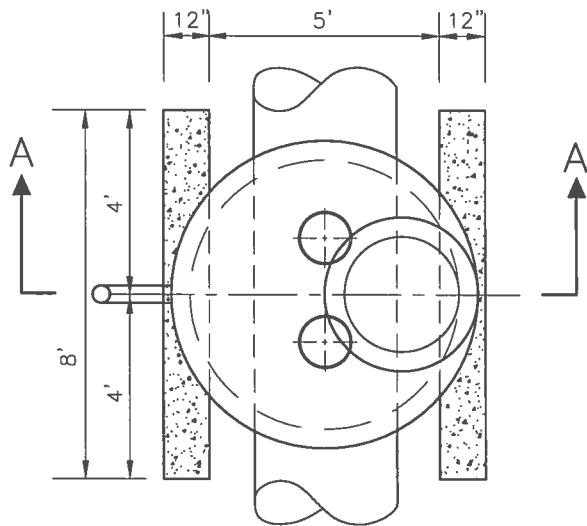

NOTE:  
USE 2-2" AIR VALVE  
ASSEMBLY ON 30" OR SMALLER  
DUCTILE IRON PIPE.

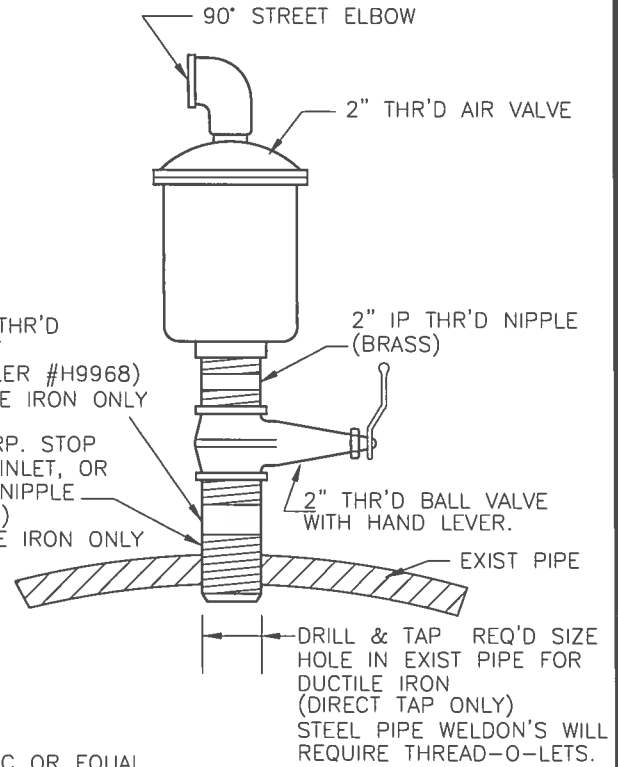

DETAIL A

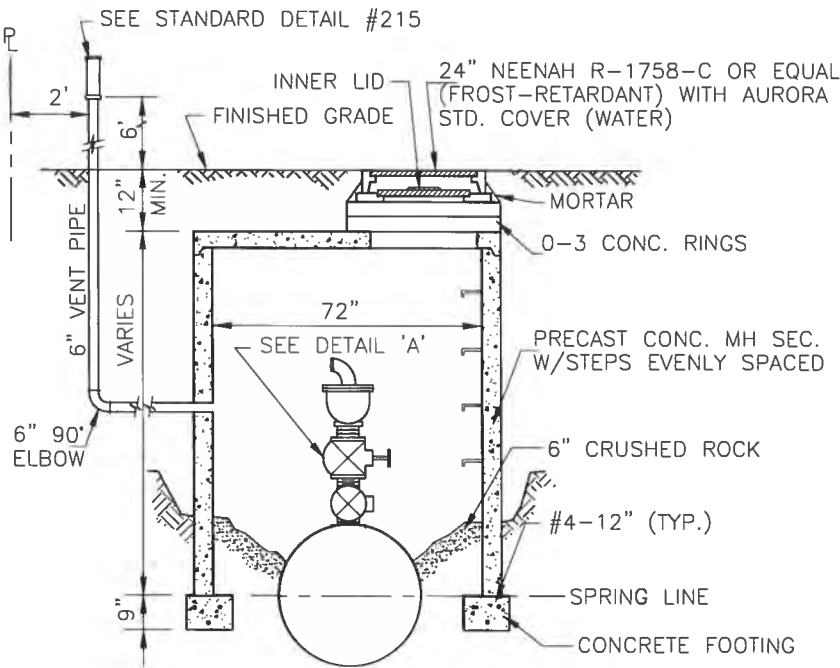

SECTION A-A

NOTES

1. TURN DISCHARGE PORT AWAY FROM VALVES AND ACCESS OPENING.
2. 3" AND LARGER AIR VACS WILL BE PROVIDED WITH EITHER WAFER OR STAND BUTTERFLY VALVES WITH HAND WHEEL OPERATORS.

DRAFT STANDARDS UNIT - STD 211-2

*KE*  
*1/23/12*  
*Kevin Weyner* 2-6-12  
CITY ENGINEER DATE  
*Chris 2 Str* 2/7/12  
AURORA WATER DATE

**AIR & VACUUM VALVE  
INSTALLATION**

2 of 3  
**211**

# STANDARD

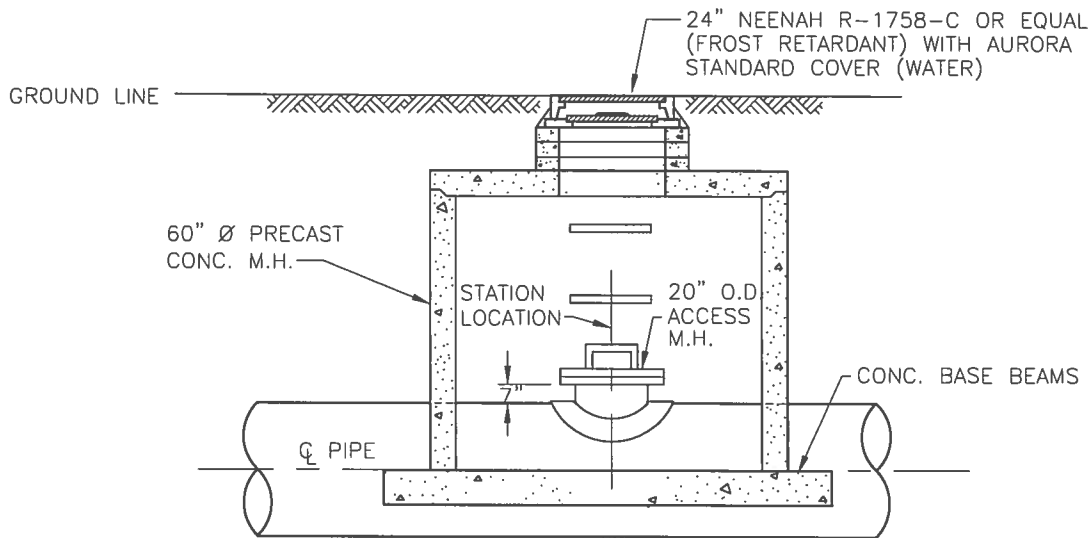

ACCESS MANHOLE

NOTE:  
USE 2" AIR VALVE  
ASSEMBLY ON 30" OR  
SMALLER DUCTILE IRON  
PIPE

FOR VENT PIPE  
DETAILS SEE  
SHEET NO. 215 & 216.

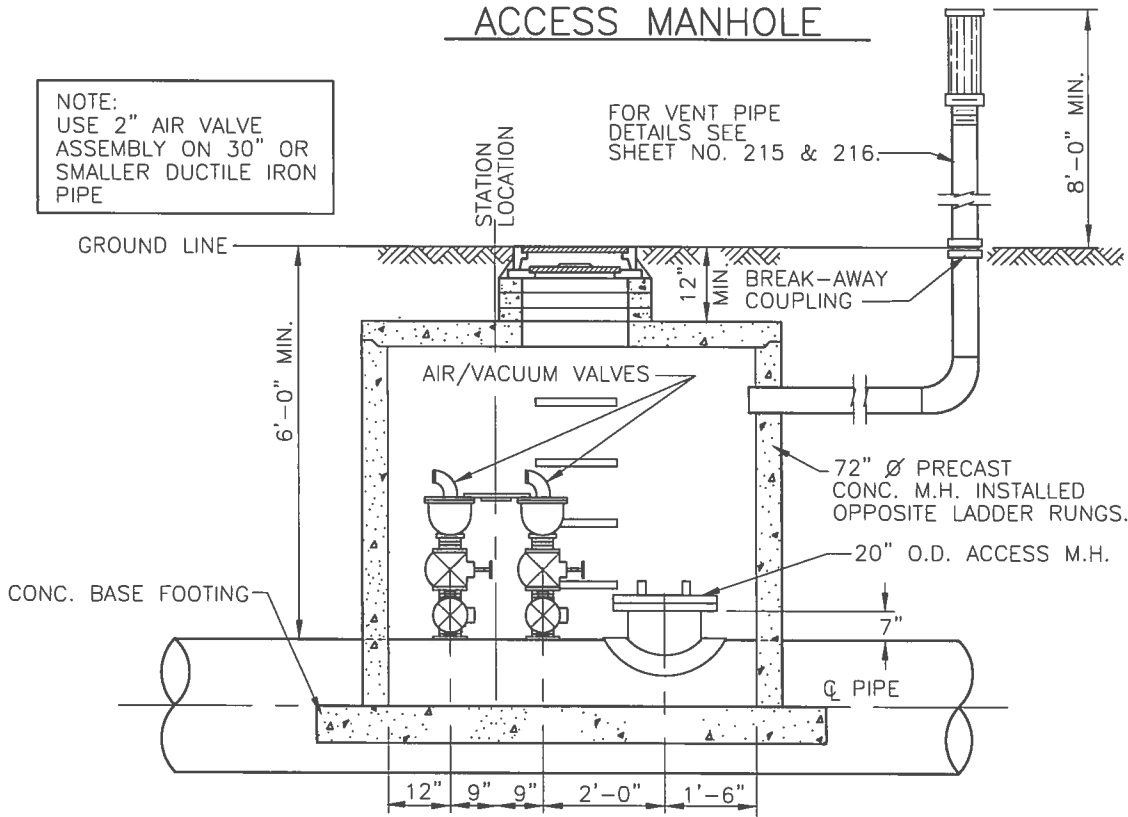

AIR VALVE ASSEMBLY WITH ACCESS MANHOLE

NOTE:

- LADDER RUNGS ARE REQUIRED IN PRECAST MANHOLES. THE DISTANCE BETWEEN RUNGS, CLEATS AND STEPS SHALL NOT EXCEED 12" AND SHALL BE UNIFORM THROUGHOUT THE LENGTH OF THE LADDER.

DRAFT STANDARDS UTIL - STD 211-3

<p><i>1/23/12</i> <i>Kevin Wegener</i> CITY ENGINEER</p>	<p>2-6-12 DATE</p>
<p><i>Chris J. St...</i> AURORA WATER</p>	<p>2/7/12 DATE</p>

**AIR VALVE ASSEMBLY  
WITH ACCESS MANHOLE**

3 of 3

211

# STANDARD

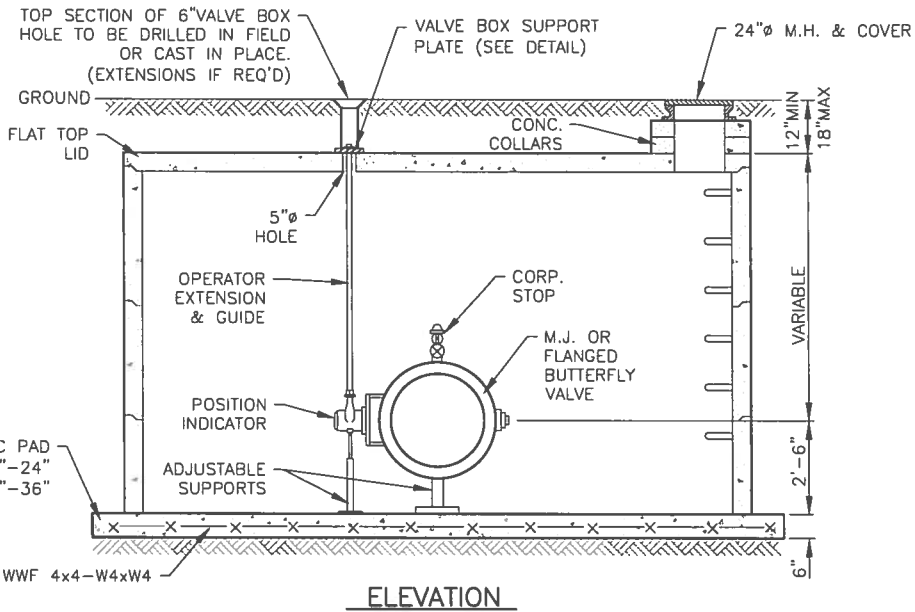
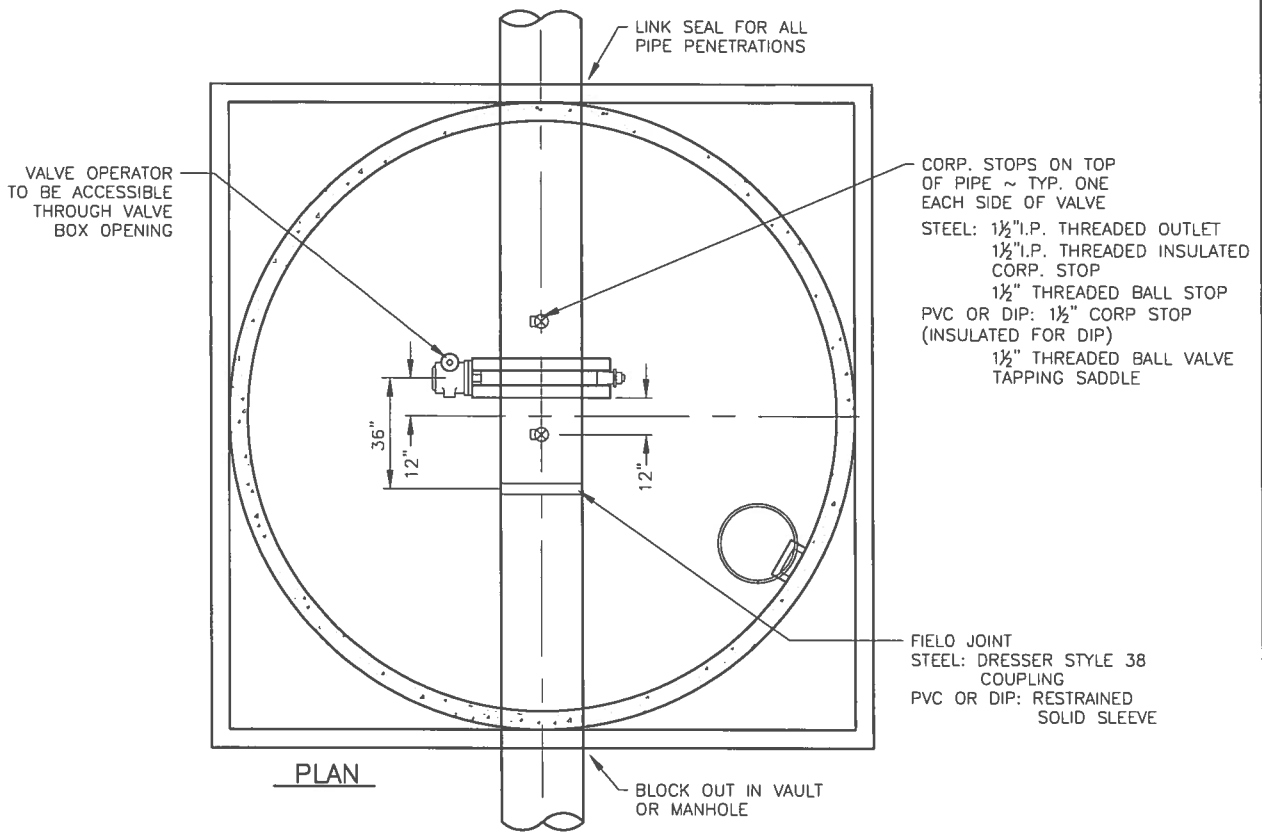

**NOTES:**

1. THE DISTANCE BETWEEN RUNGS, CLEATS, AND STEPS SHALL NOT EXCEED 12 INCHES AND SHALL BE UNIFORM THROUGHOUT THE LENGTH OF THE LADDER.
2. 8" I.D. MIN. DIAM. MANHOLE FOR 16" & 24" VALVES. 9" I.D. MIN. SQUARE VAULT FOR 30" & 36" VALVES.

DRAFT STANDARD UTIL - STD 212

1/23/12  
*Kerin Wegener* 2-6-12  
 CITY ENGINEER DATE  
*Chris 2 SA* 2/7/12  
 AURORA WATER DATE

## BUTTERFLY VALVE INSTALLATION

212

# STANDARD

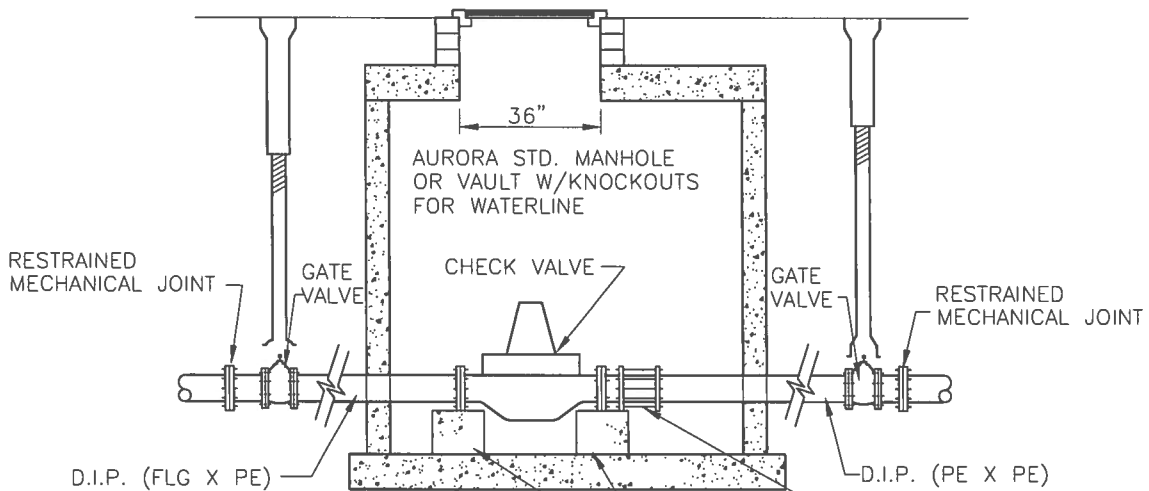
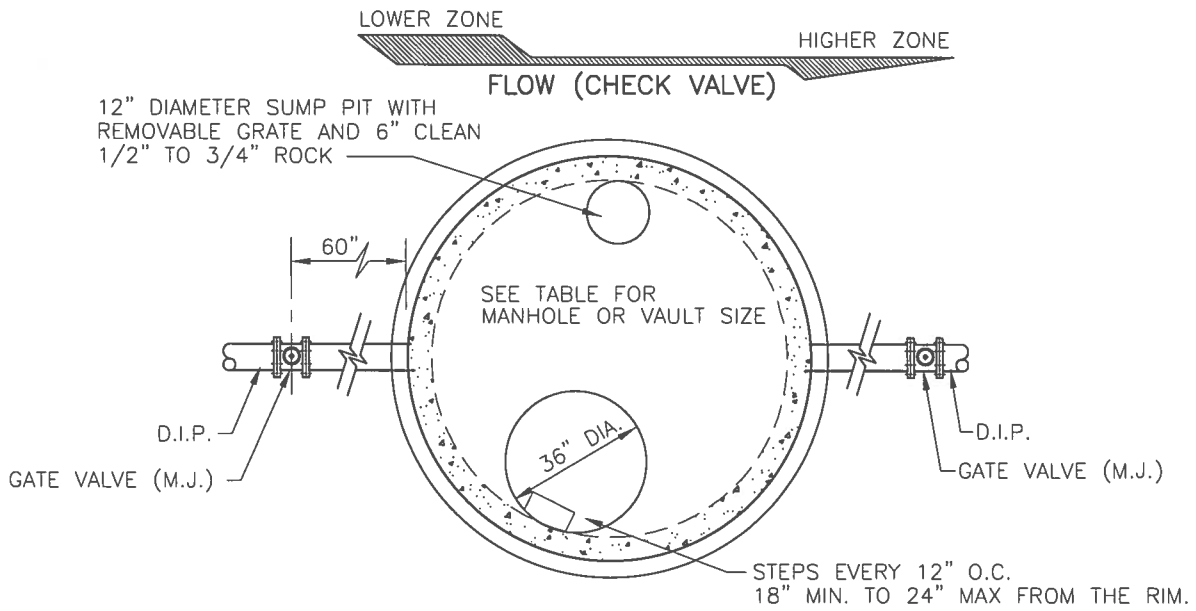

6' X 6" THICK REINFORCED CONCRETE BASE POURED IN PLACE OR PRECAST (8' X 6" THICK REQUIRED FOR 72" VAULT)

6" X 6" REINFORCED CONCRETE SUPPORT OR ADJUSTABLE JACKSTANDS

**NOTES:**

1. KNOCKOUTS TO BE GROUTED SHUT.
2. GATE VALVES ARE REQUIRED.
3. RING & COVERS 36"-NEENAH R-1741 WITH 22" INSIDE LID, OR EQUAL, WATER CAST INTO LID, 2" ABOVE FINISHED GRADE (FLUSH IF IN PAVEMENT).
4. SEE SECTION 20.00 FOR COATING REQUIREMENTS.

CHECK VALVE SIZE	MANHOLE/VAULT DIA.
UP TO 2"	48"
2" TO 12"	72"
LARGER THAN 12"	SPECIAL DESIGN

DRAFT STANDARD UTIL-STD-213

*KEW*  
 2/23/12  
*Kevin Wegener* 2-6-12  
 CITY ENGINEER DATE  
*Chris 29A* 2/7/12  
 AURORA WATER DATE

**TYPICAL CHECK VALVE STATION**

**213**

# STANDARD

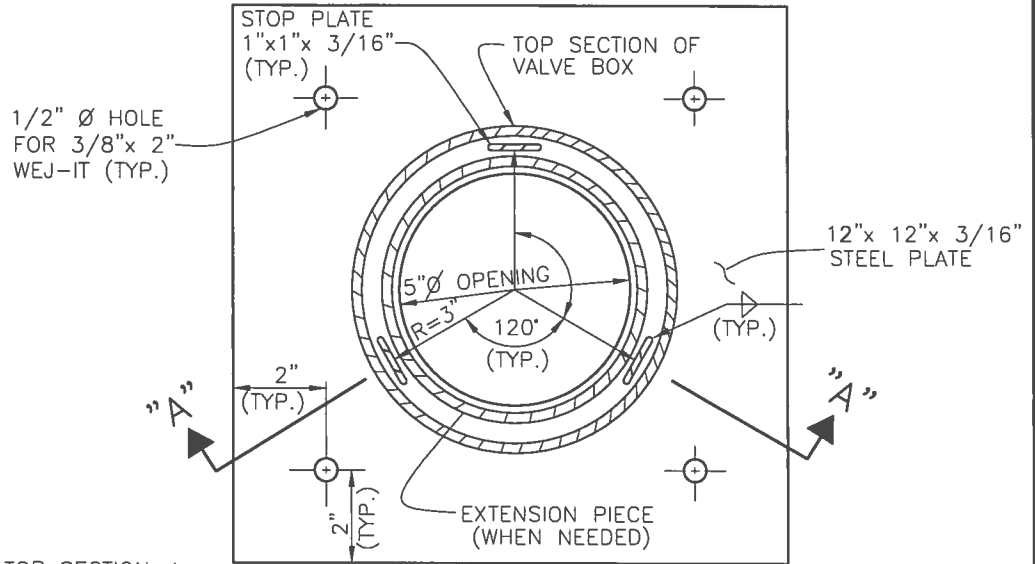

PLAN

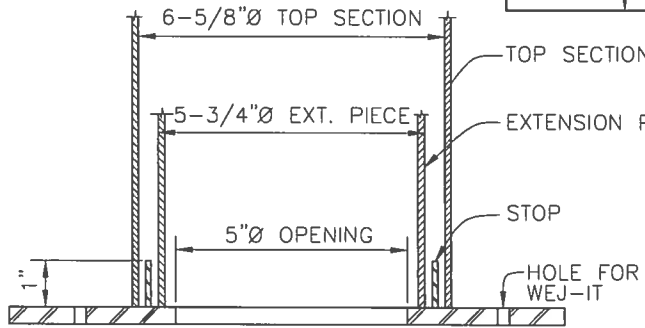

SECTION "A"-"A"

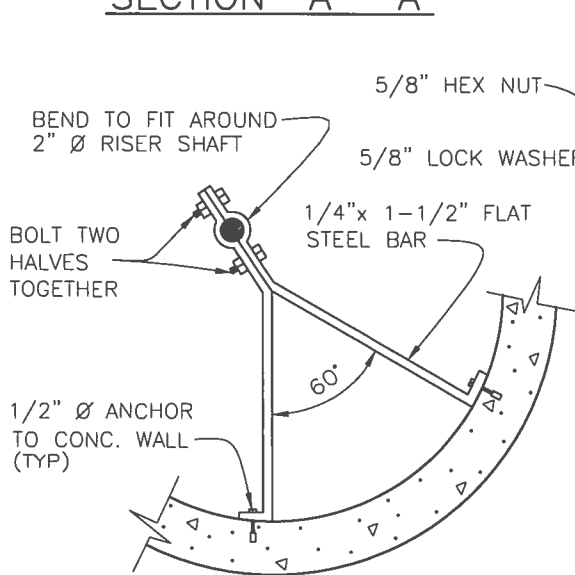
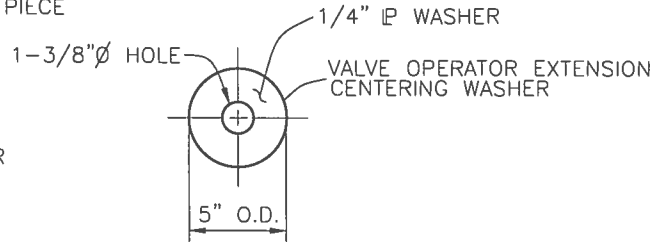

EXTENSION GUIDE

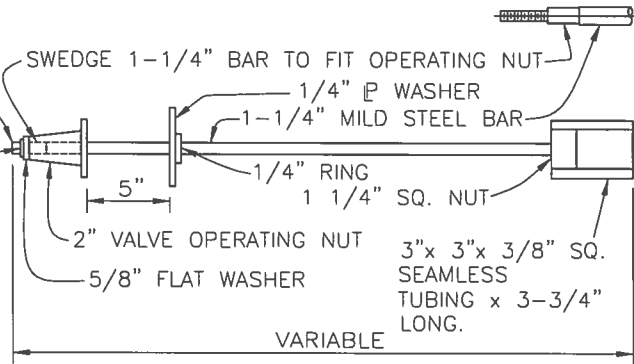

VALVE OPERATOR EXTENSION

UNIVERSAL EXTENSION KEY NOT ALLOWED

DRAFT STANDARDS UTIL-STD V214

<p><i>KEW</i>  <i>Kevin Wegener</i> 2-6-12                  CITY ENGINEER DATE</p> <p><i>Clayton</i> 2/7/12                  AURORA WATER DATE</p>	<p style="text-align: center;"><b>VALVE BOX SUPPORT PLATE                  AND VALVE OPERATOR                  EXTENSION GUIDE</b></p>
--	--

214

# STANDARD

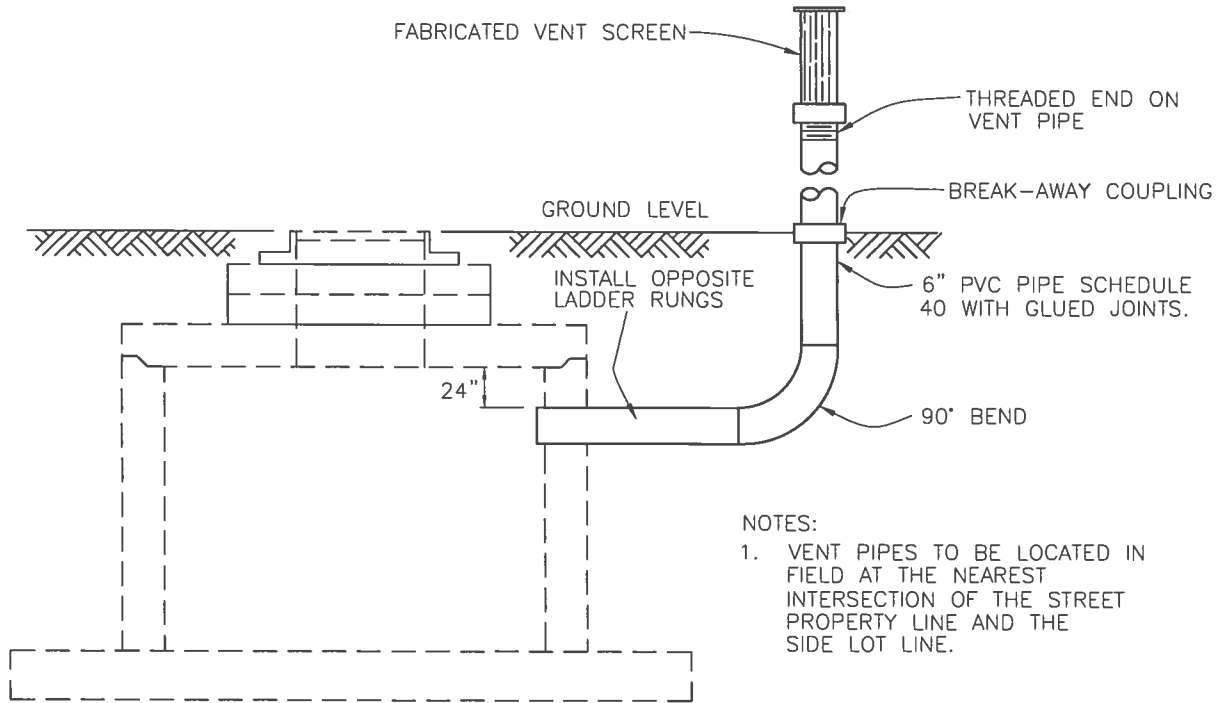

## VENT PIPE INSTALLATION

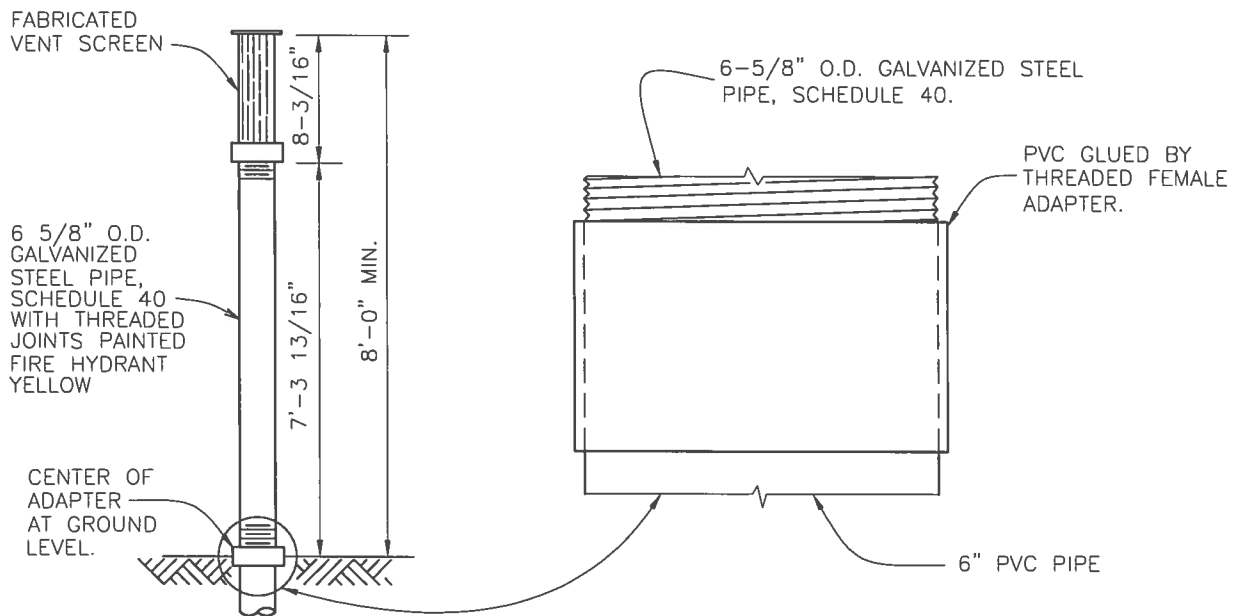

## VENT PIPE AND BREAK-AWAY COUPLING DETAILS

DRAFT STANDARDS UTIL - STD 215

1/23/12  
*Kevin Wegener* 2-6-12  
 CITY ENGINEER DATE  
*Chris J. A.* 2/7/12  
 AURORA WATER DATE

VENT PIPE  
 INSTALLATION DETAILS

215



STANDARD

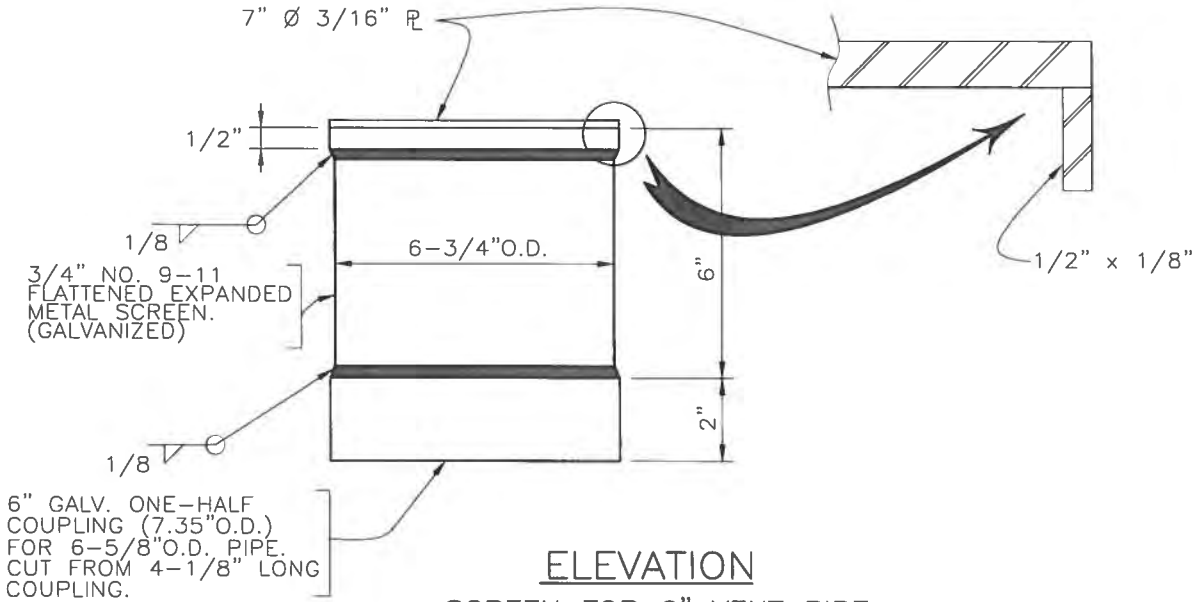

ELEVATION  
SCREEN FOR 6" VENT PIPE

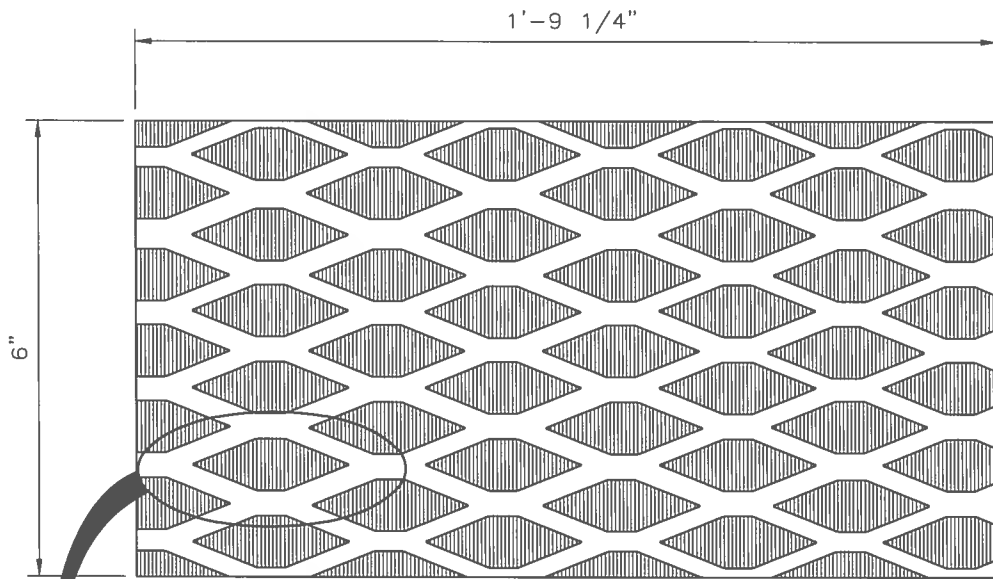

METAL SCREEN

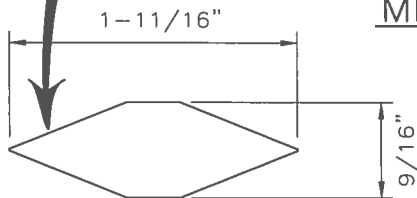

NOTE: BUG SCREEN TO BE INSTALLED  
ON INTERIOR OF METAL SCREEN.

DRAFT STANDARDS UTIL-STD-216

1/23/12  
*Kevin Weyen* 2-6-12  
 CITY ENGINEER DATE  
*Ray 29th* 2/7/12  
 AURORA WATER DATE

6" DIAMETER  
VENT PIPE SCREEN

216

STANDARD

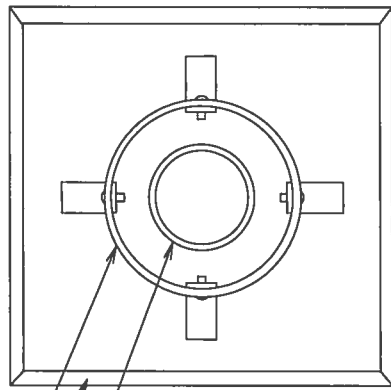

6" VENT PIPE  
CONCRETE PAD  
20 GA. VENT BODY

BASE DETAIL

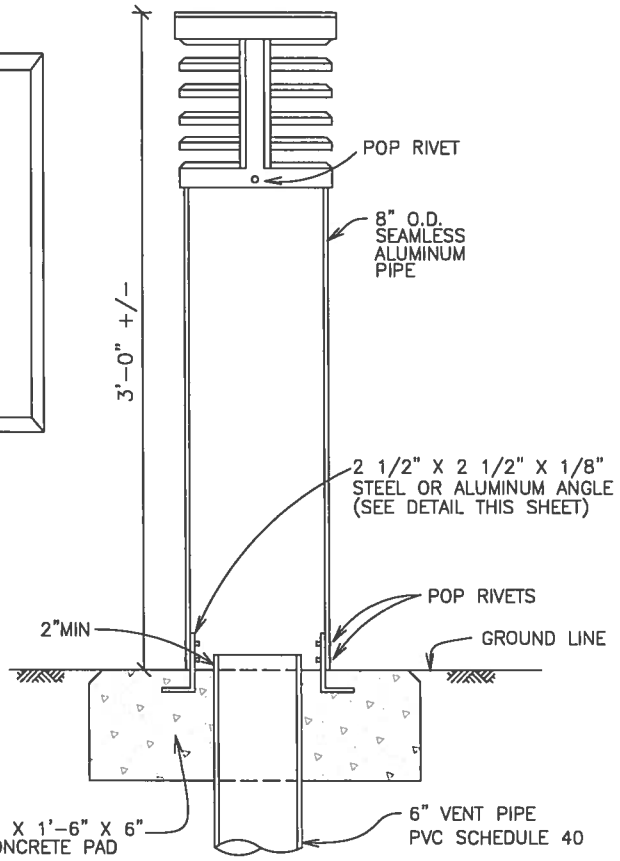

8" O.D. SEAMLESS ALUMINUM PIPE  
3'-0" +/-  
2 1/2" X 2 1/2" X 1/8" STEEL OR ALUMINUM ANGLE (SEE DETAIL THIS SHEET)  
POP RIVET  
2" MIN  
POP RIVETS  
GROUND LINE  
1'-6" X 1'-6" X 6" CONCRETE PAD  
6" VENT PIPE PVC SCHEDULE 40

ROUND VENT SCREEN

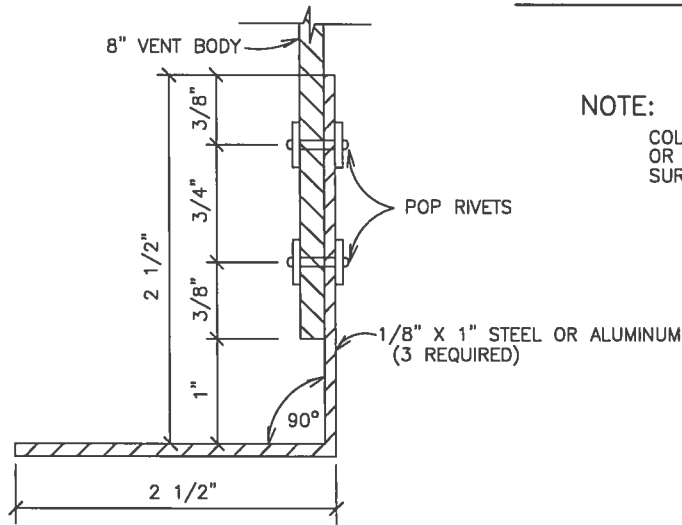

STEEL OR ALUMINUM ANGLE DETAIL

NOTE:

COLOR SHALL BE OLIVE GREEN OR FLAT BLACK TO MATCH SURROUNDINGS.

DRAFT STANDARD UTIL - STD 217

1/25/12  
Kevin Weyen 2-6-12  
CITY ENGINEER DATE  
Chris 2 SA 2/8/12  
AURORA WATER DATE

RESIDENTIAL VENT ASSEMBLY

217

# STANDARD

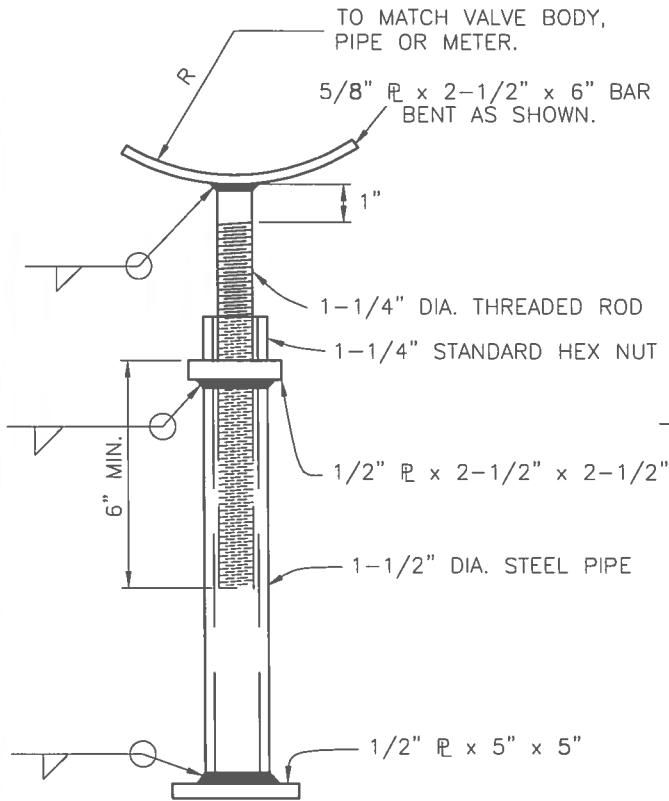

ADJUSTABLE-SUPPORT  
(STANDARD)

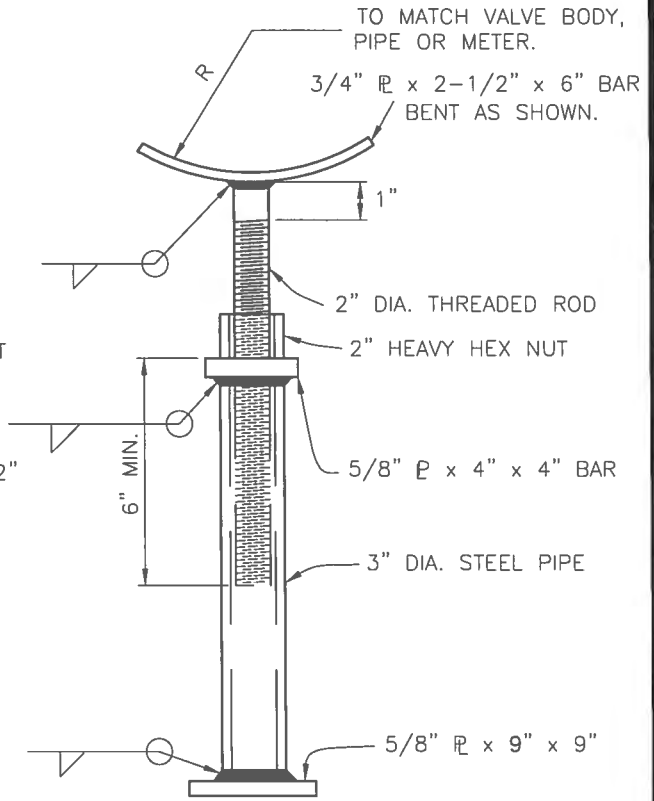

ADJUSTABLE-SUPPORT  
(HEAVY DUTY)

DRAFT STANDARDS UTIL.-STDV218

#15  
2/23/12  
*Kevin Wegener* 2-6-12  
CITY ENGINEER DATE  
*Chris 20A* 2/8/12  
AURORA WATER DATE

ADJUSTABLE STEEL PIPE  
VALVE SUPPORT

218

# STANDARD

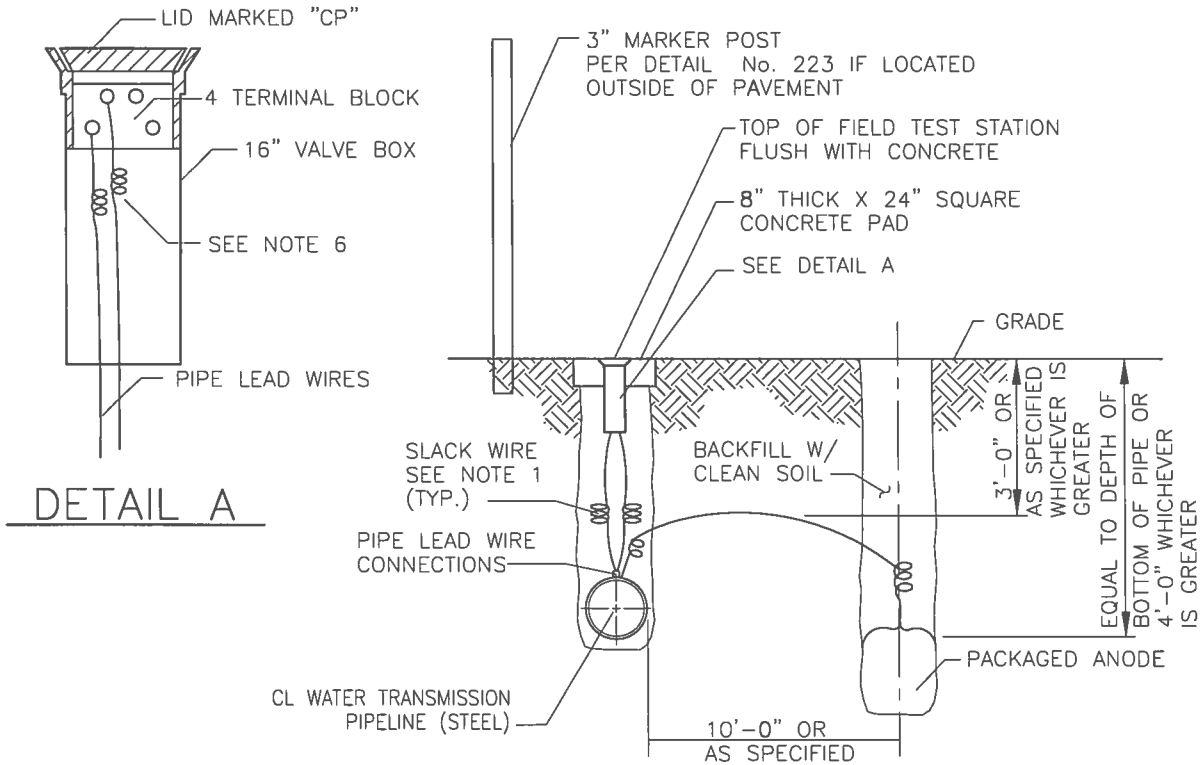

NOTES

1. ALL LEAD WIRES BURIED IN THE EARTH ABOVE THE PIPE AND ABOVE THE ANODE SHALL BE INSTALLED WITH A MINIMUM OF 18" SLACK TO PREVENT STRESSING OF WIRE OR DIMINISHING THE SLACK REQUIRED IN THE TEST STATION VAULT BECAUSE OF BACKFILL SETTLEMENT.
2. PIPE LEAD WIRES SHALL BE ATTACHED APPROXIMATELY 12" APART ON THE TOP CENTERLINE OF THE PIPE.
3. AT LEAST 5 GALLONS OF WATER SHALL BE Poured OVER THE ANODE BEFORE BACKFILLING.
4. PERMANENT, LEGIBLE IDENTIFICATION MARKERS SHALL BE ATTACHED TO EACH LEAD WIRE IN THE FIELD TEST STATION.
5. ALL MATERIALS AND INSTALLATION SHALL BE AS SPECIFIED.
6. LEAD WIRES INSIDE THE TEST STATION VAULT SHALL BE PROVIDED WITH SUFFICIENT SLACK TO LIFT THE TERMINAL BOARD A MINIMUM OF 12" ABOVE THE VAULT TO ALLOW ACCESS TO THE CONNECTIONS, YET ALLOW THE TERMINAL BOARD AND LID TO BE INSTALLED IN THE VAULT WITHOUT BINDING ON THE SLACK WIRES.

## SACRIFICIAL ANODE INSTALLATION W/ BELOW GROUND FIELD TEST STATION

DRAFT STANDARDS/VUL-STD\219

*1/25/12*  
*Kevin W. Gerner* 2-6-12  
 CITY ENGINEER DATE  
*Chris J. Str* 2/8/12  
 AURORA WATER DATE

**SACRIFICIAL ANODE  
INSTALLATION**

**219**

# STANDARD

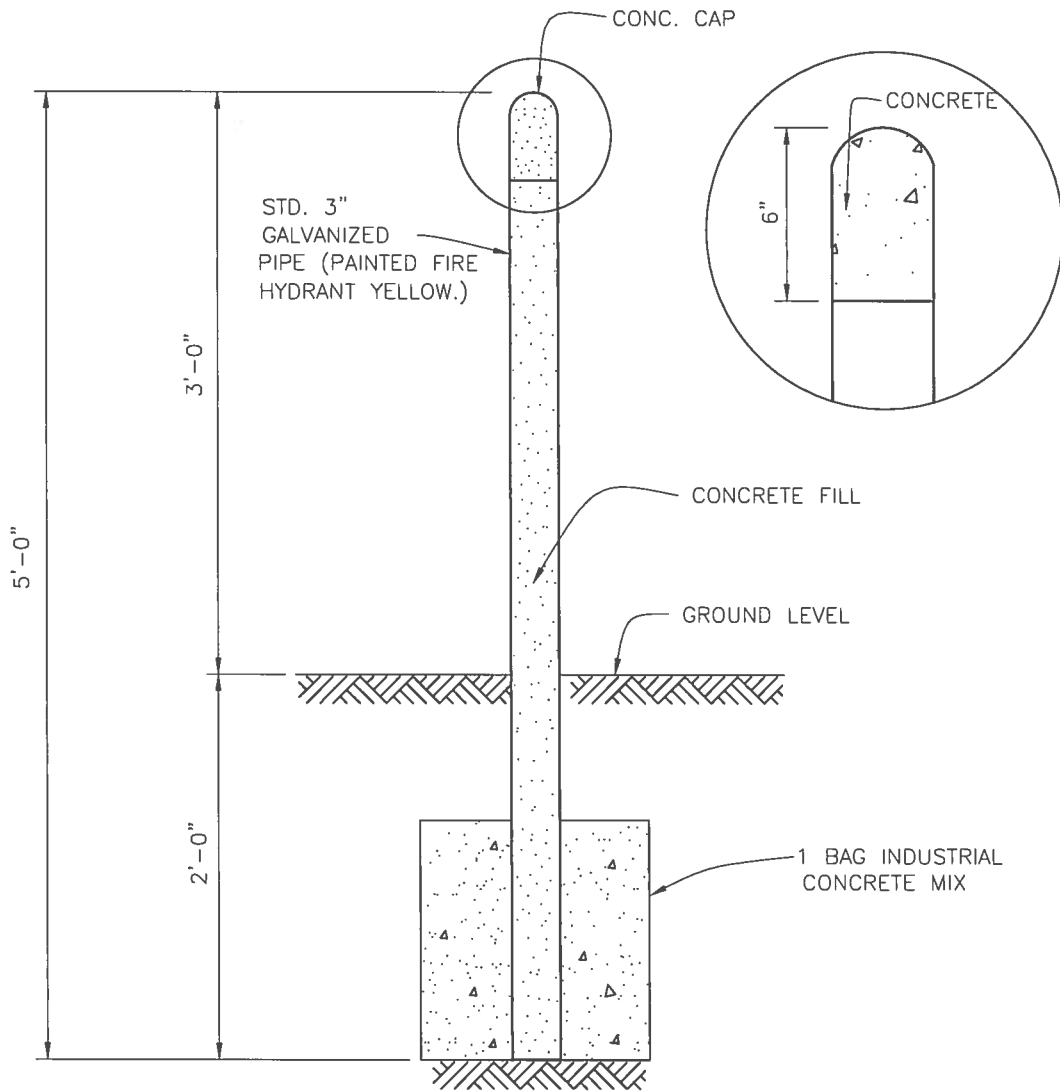

NOTE: VALVE BOXES LOCATED OUTSIDE OF PAVEMENT SHALL BE PROVIDED AN 18" SQUARE BY 4" DEEP CONCRETE COLLAR.

IDENTIFICATION MARKS ON POSTS SHALL BE 3" DIA. CIRCLES BROKEN IN VERTICAL CENTER (○) POINTING TO APPURTENANCE, WITH 1" STENCILS INSIDE CIRCLE INDICATING TYPE OF APPURTENANCE (MH, 12" GATE VALVE, ETC.) AND THE DISTANCE IN FEET AND INCHES FROM POST.

MARKER POSTS SHALL BE LOCATED NO FURTHER THAN 3 FEET FROM THE APPURTENANCE.

DRAFT STANDARDS UTIL - STD 220

*1/25/12*  
*Kevin Weymer* 2-6-12  
 CITY ENGINEER DATE  
*Chris Zota* 2/8/12  
 AURORA WATER DATE

REFERENCE POST  
TYPICAL DETAIL

220

# STANDARD

## BEARING THRUST BLOCKS MINIMUM BEARING SURFACE AREA ( $A_b$ ) (IN SQUARE FEET) (BASED ON A MINIMUM SOIL BEARING CAPACITY OF 2000PSF)

	SIZE OF PIPE	BENDS				TEE OR DEAD END
		11 1/4'	22 1/2'	45'	90'	
$P_p=2000$ PSF	6"	1.0	1.5	3.0	5.3	4.0
	8"	1.5	2.5	5.0	9.5	6.5
	12"	3.0	5.5	10.5	19.5	14.0
	16"	4.0	7.0	14.0	25.5	18.0
	24"	8.0	15.5	30.0	56.0	40.0

## LENGTH OF TIED PIPE (ft)

SIZE OF PIPE	HORIZONTAL BENDS				TEE OR DEAD END
	11 1/4'	22 1/2'	45'	90'	
6"	4.0	8.0	17.0	42.0	55.0
8"	5.0	11.0	23.0	54.0	73.0
12"	8.0	16.0	33.0	79.0	106.0
16"	10.0	20.0	43.0	103.0	140.0
24"	15.0	30.0	62.0	149.0	207.0

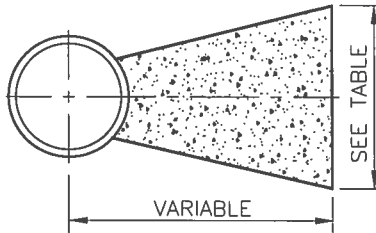

SECTION X-X

**NOTES:**

1. ALL FITTINGS SHALL BE HARNESS RODDED IN ACCORDANCE TO STANDARD No. 225.
2. ALL METAL SHALL BE WRAPPED IN POLYETHYLENE IN ACCORDANCE WITH THESE SPECIFICATIONS.
3. LARGE DIAMETER LINES WILL REQUIRE ENGINEERING DESIGN AND CALCULATIONS SUBMITTED AND APPROVED.
4. IF THE BRANCH OF A TEE OR WET-TAP IS LESS THAN ONE HALF THE DIAMETER OF THE MAIN, THRUST BLOCK IS NOT REQUIRED.
5. LARGER THAN 24" BY DESIGN.

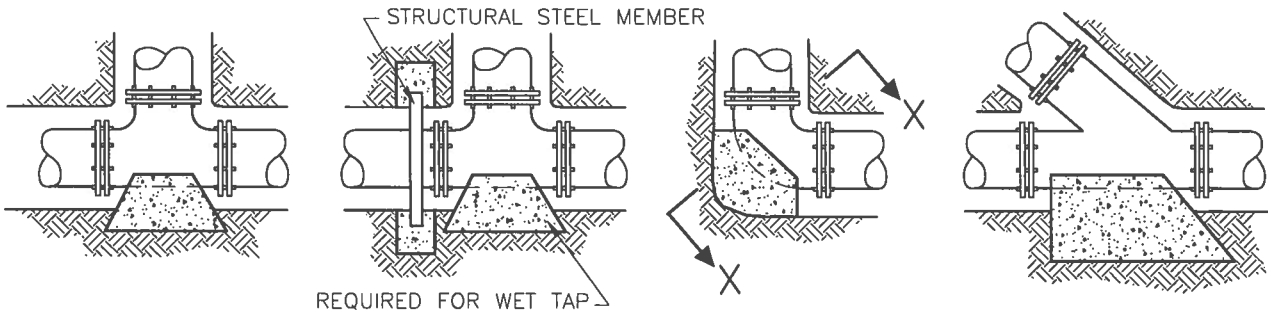

DRAFT STANDARDS (UTL-STD) 221

*11/25/12*  
*Kevin Weyer* 2-6-12  
 CITY ENGINEER DATE  
*Clay J. St.* 2/8/12  
 AURORA WATER DATE

**THRUST BLOCK LOCATION  
AND BEARING  
AREAS & VOLUMES**

221

# STANDARD

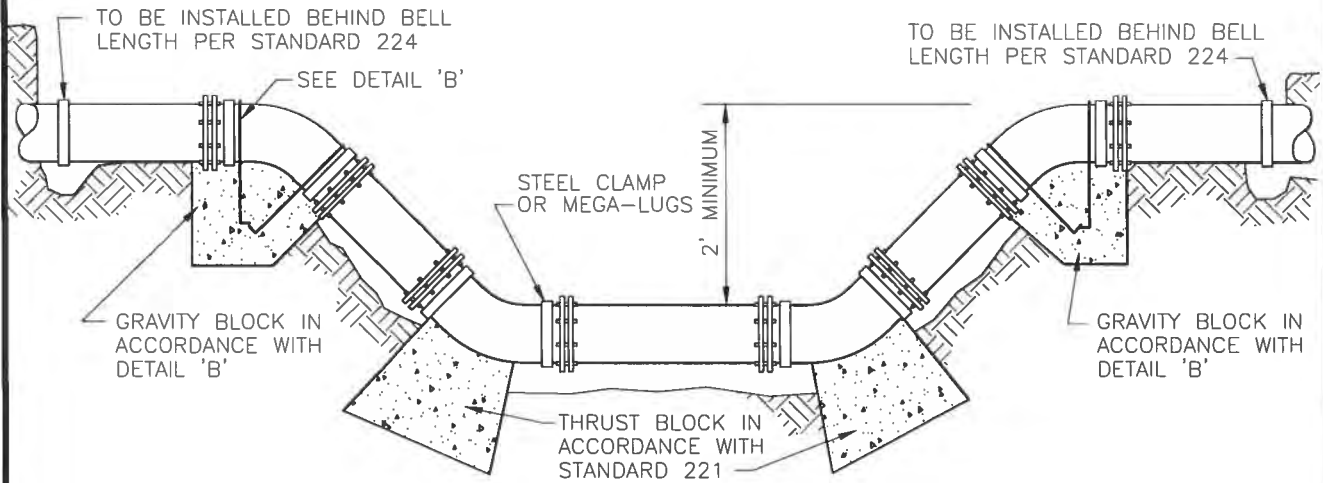

## WATERLINE LOWERING DETAIL

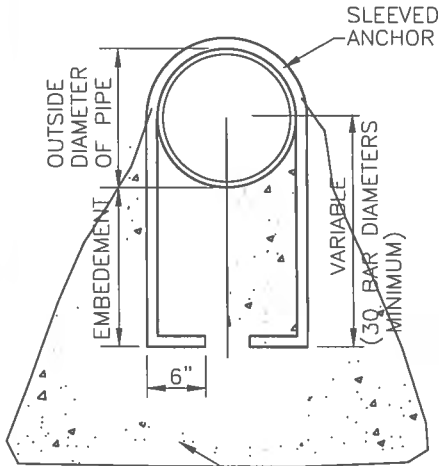

**DETAIL B**

### GRAVITY BLOCKS MINIMUM VOLUME (IN CUBIC FEET)

SIZE OF PIPE	BENDS		
	11 1/4°	22 1/2°	45°
6"	10.5	20.5	40.0
8"	17.5	35.0	68.0
12"	37.0	74.0	145.0
16"	48.5	96.0	189.0
24"	106.0	211.0	414.0

LARGER THAN 24" BY SPECIAL DESIGN

GRAVITY BLOCKS SHALL BE CONICAL IN SHAPE

**NOTES:**

1. VERTICAL 90° BENDS ARE NOT ALLOWED.
2. ALL LINES 12" AND LARGER WILL REQUIRE BODY CLAMPS (NATIONAL PIPE HANGER HEAVY TWO-BOLT PIPE CLAMP OR APPROVED EQUAL) APPROPRIATELY SIZED ALL-THREAD AND DOUBLE NUT.
3. THERE SHALL BE A MINIMUM CLEARANCE OF 24" BETWEEN WATERLINE AND ANY NEW CONSTRUCTION.
4. ALL JOINTS SHALL BE RESTRAINED BETWEEN THE FITTINGS.
5. ANCHORS SHALL BE SLEEVED TO PREVENT CORROSION OF THE PIPE AND/OR BAR. THIS COULD INCLUDE, BUT NOT LIMITED TO, REINFORCED GARDEN HOSE, CURVED FIBERGLASS BOARD, ETC.

DRAFT STANDARDS UTIL-STD-222

*Kevin Wegener* 2-6-12  
 CITY ENGINEER DATE  
*Clay 29th* 2/8/12  
 AURORA WATER DATE

## WATER LINE LOWERING DETAIL

**222**

# STANDARD

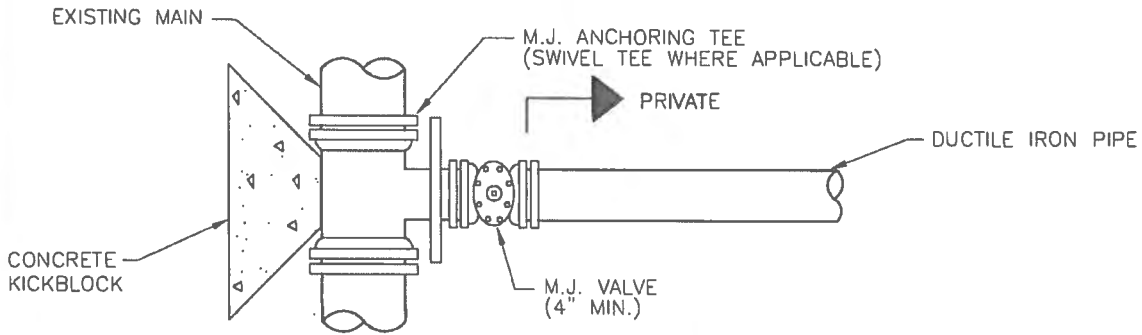

FIRELINE OR 4" & LARGER DOMESTIC CONNECTION WITH MAIN EXTENSION

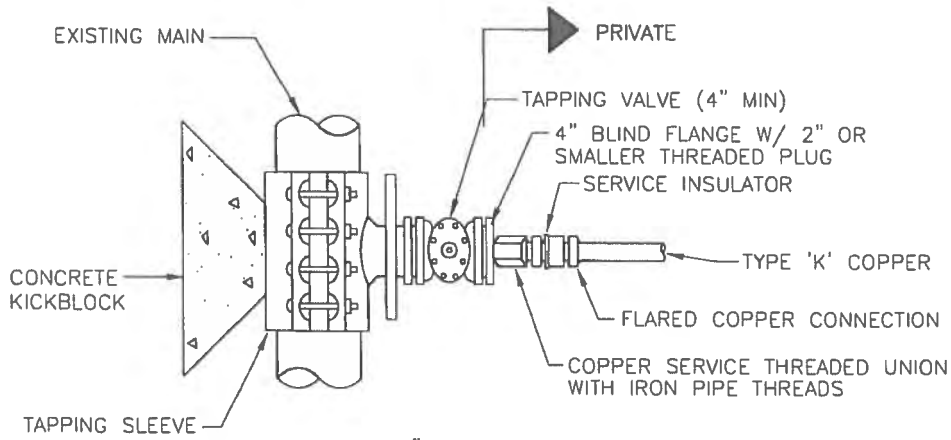

2" OR SMALLER FIRELINE

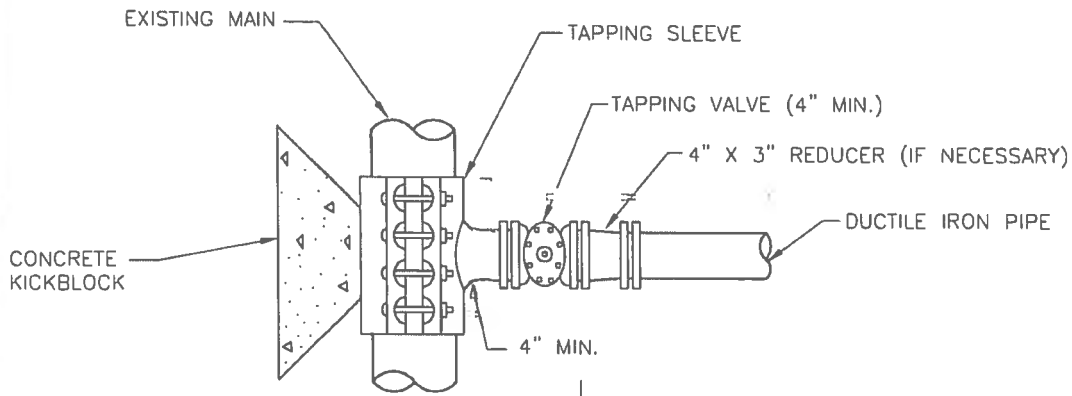

3" OR LARGER FIRELINE CONNECTION

- NOTE: 1. ALL PIPE SHALL BE WRAPPED IN POLYETHYLENE AND RESTRAINED  
 2. RODDING TO BE INDIVIDUALLY POLYWRAPPED.

DRAFT STANDARD UTIL - STD 223-1

*1/23/12*  
*Kevin Wegner* 2-6-12  
 CITY ENGINEER DATE  
*Chris Stoltz* 2/8/12  
 AURORA WATER DATE

**THRUST BLOCK & TIE BACK  
 DETAIL (FIRE SUPPRESSION  
 SYSTEMS ONLY)**

1 of 4  
**223**



STANDARD

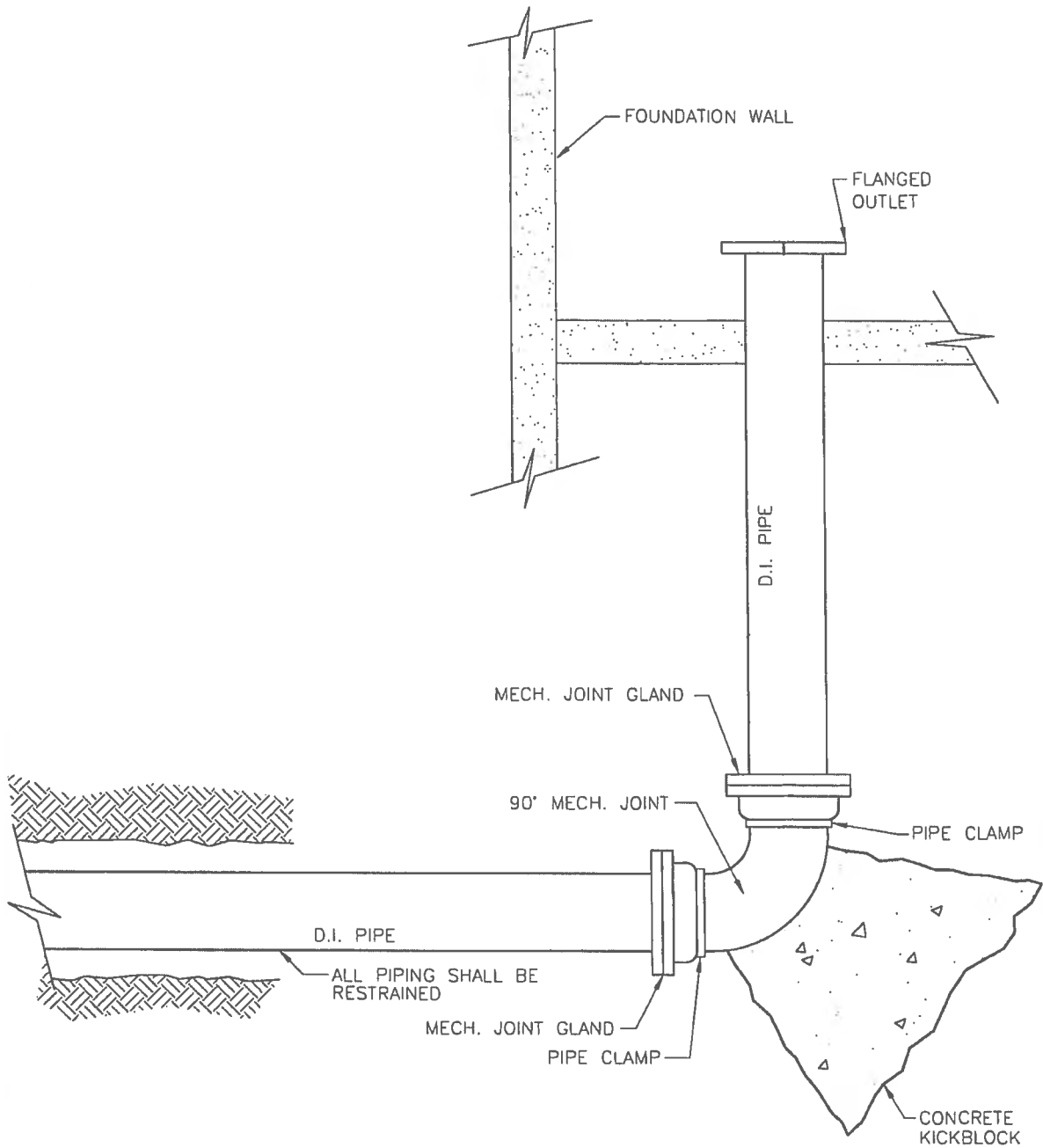

DRAFT STANDARDS/UTL-5TH/223-2

*KEW*  
*1/23/12*  
*Kevin Wegener* 2-6-12  
 CITY ENGINEER DATE  
*Chris Z Str* 2/8/12  
 AURORA WATER DATE

THRUST BLOCK & TIE BACK  
 DETAIL (FIRE SUPPRESSION  
 SYSTEMS ONLY

2 of 4  
 223

STANDARD

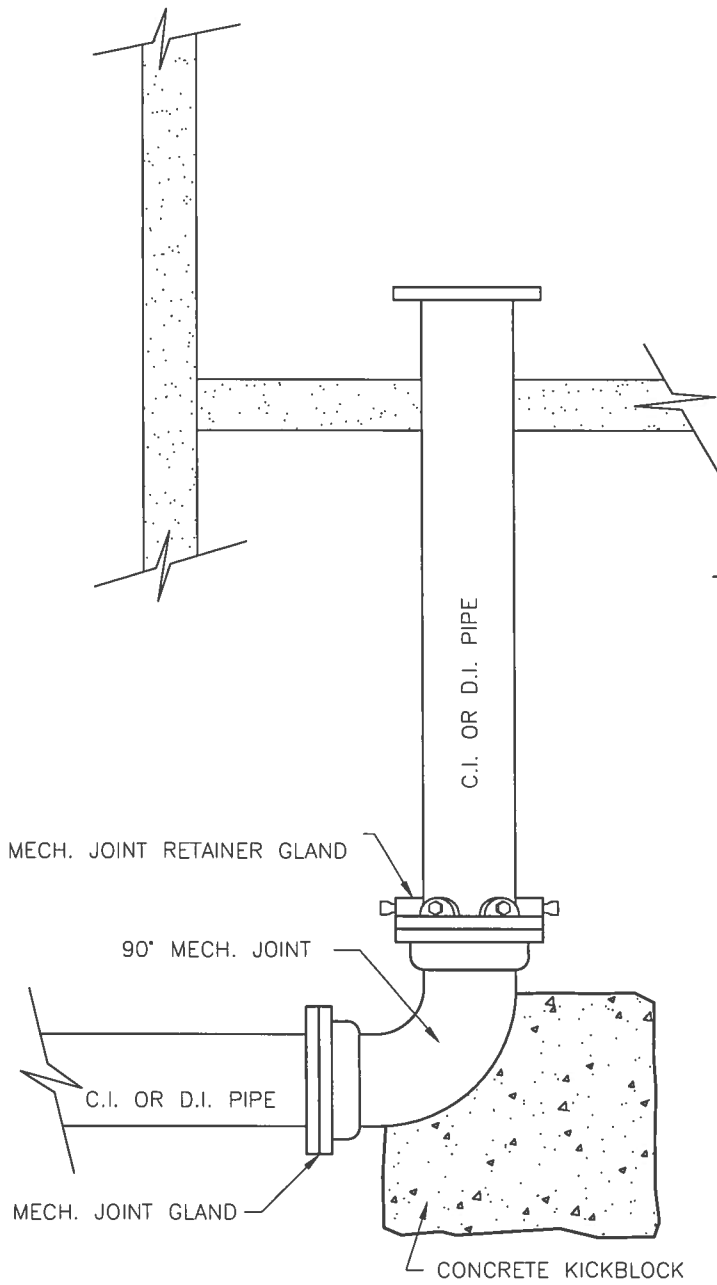

FLANGE SPIGOT

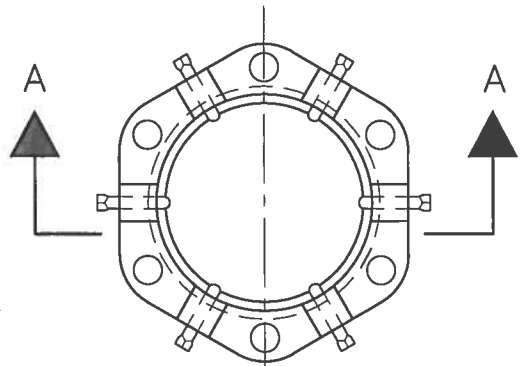

MECHANICAL JOINT  
DUCTILE IRON RETAINER  
GLAND

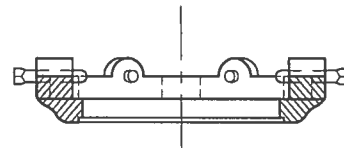

SECTION A-A

NOTE: SUCH DEVICES SHOULD BE  
TORQUED TO MANUFACTURERS  
RECOMMENDATIONS

DRAFT STANDARDS (UTL-STD) 223-3

1/23/12  
*Kevin Wegener* 2-6-12  
 CITY ENGINEER DATE  
*Clay J. St...* 2/8/12  
 AURORA WATER DATE

THRUST BLOCK & TIE BACK  
 DETAIL (FIRE SUPPRESSION  
 SYSTEMS ONLY)

3 of 4  
 223

# STANDARD

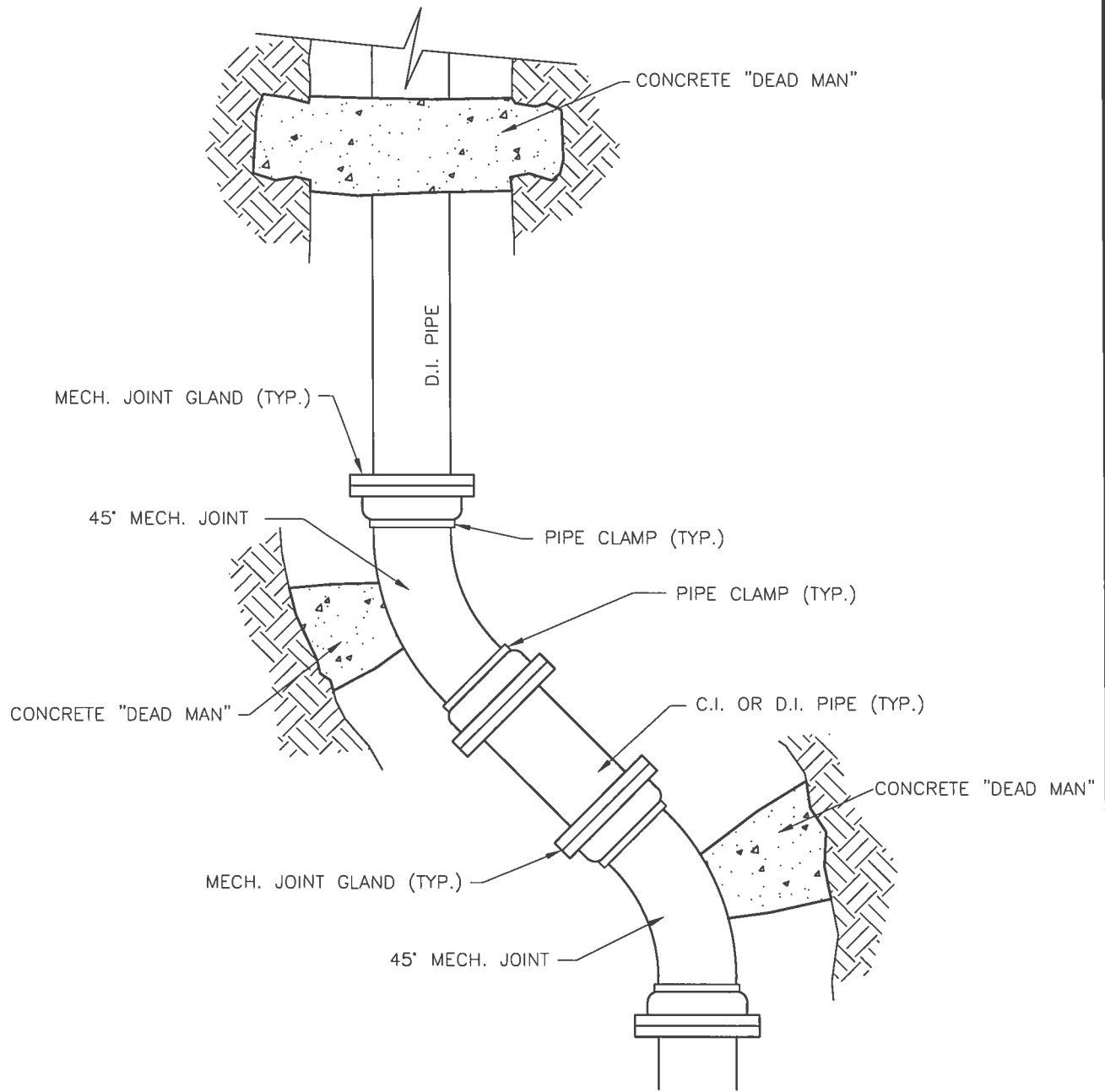

DRAFT\STANDARDS\UTL-STD\223-4

<p><i>2/5/12</i>  <i>Kevin Weyers</i>                  CITY ENGINEER</p>	<p>2-6-12                  DATE</p>
<p><i>Chris ZSA</i>                  AURORA WATER</p>	<p>2/8/12                  DATE</p>

THRUST BLOCK & TIE BACK  
 DETAIL (FIRE SUPPRESSION  
 SYSTEMS ONLY)

4 of 4  
**223**

# STANDARD

## TYPICAL REDUCED PRESSURE BACKFLOW PREVENTION DEVICE

### DESCRIPTION:

THE REDUCED PRESSURE BACKFLOW PREVENTER OPERATES ON THE PRINCIPLE THAT WATER WILL NOT FLOW FROM A ZONE OF LOWER PRESSURE TO ONE OF HIGHER PRESSURE. IT PROVIDES MAXIMUM PROTECTION AGAINST BACKFLOW CAUSED BY BOTH BACKPRESSURE AND BACKSIPHONAGE.

THE DEVICE CONSISTS OF TWO SPRING-LOADED CHECK VALVES (A AND B) AND A SPRING-LOADED DIAPHRAGM ACTUATED DIFFERENTIAL PRESSURE RELIEF VALVE (C) LOCATED IN THE ZONE BETWEEN THE CHECK VALVES.

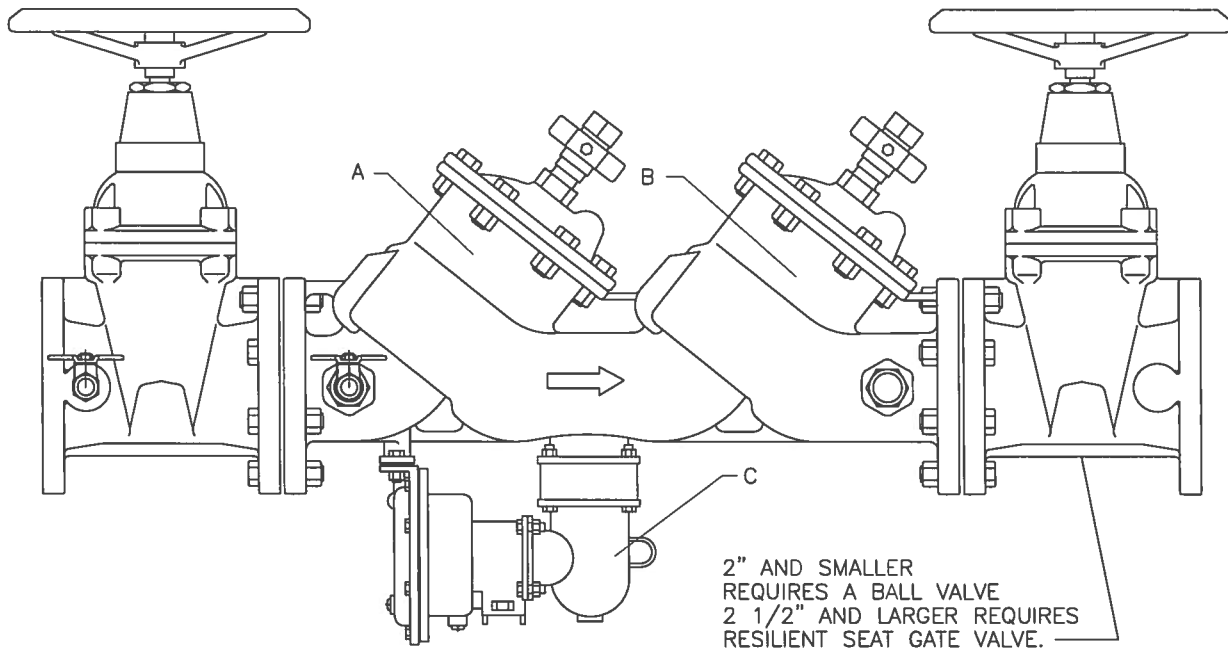

### OPERATION:

THE FIRST CHECK VALVE (A) CAUSES ALL WATER PASSING THROUGH IT TO BE AUTOMATICALLY REDUCED IN PRESSURE.

THE SECOND CHECK VALVE (B) IS LIGHTLY SPRING-LOADED AND FORMS THE "DOUBLE CHECK" FEATURE OF THE DEVICE. IT ACTS TO PREVENT UNNECESSARY DRAINAGE OF THE DOMESTIC SYSTEM IN CASE A BACKFLOW CONDITION OCCURS.

THE RELIEF VALVE (C) IS SPRING-LOADED TO REMAIN OPEN, AND DIAPHRAGM ACTUATED TO CLOSE BY MEANS OF DIFFERENTIAL PRESSURE.

SEE DETAIL 225 FOR FLOOR DRAIN CAPACITIES.

SEE SECTION 19.00 FOR ADDITIONAL REQUIREMENTS.

DRAFT STANDARD UTIL - STD 224

*11/23/12*  
*Klein Weyman* 2-6-12  
CITY ENGINEER DATE  
*Chris 2/8/12*  
AURORA WATER DATE

BACKFLOW PREVENTION  
DEVICE

224

# STANDARD

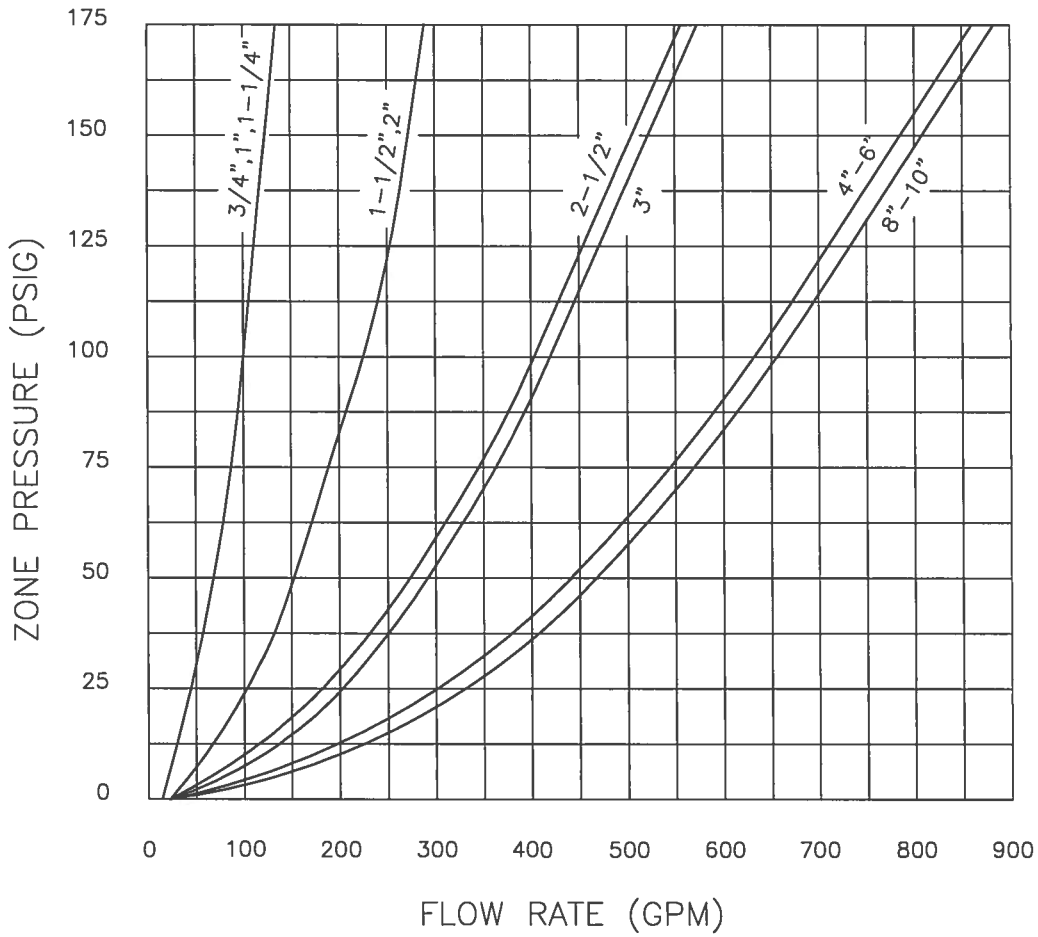

TYPICAL FLOW RATES  
AS SIZED BY FLOOR  
DRAIN MANUFACTURERS

- 2" 55 GPM
- 3" 112 GPM
- 4" 170 GPM
- 5" 350 GPM
- 6" 450 GPM
- 8" 760 GPM

NOTE:  
FLOOR DRAIN CAPACITIES ARE ESTABLISHED BY THE FLOOR  
DRAIN MANUFACTURERS.

DRAFT STANDARDS UTIL - STD \ 225

*1/23/12*  
*Kevin Wegner* 2-6-12  
 CITY ENGINEER DATE  
*Clay 28th* 2/8/12  
 AURORA WATER DATE

**BACKFLOW PREVENTOR  
DRAIN FLOW CHART**

**225**

# STANDARD

NOTE:  
OUTSIDE COVERS  
MUST HAVE DOORS  
FOR ACCESS TO  
TEST COCKS FOR  
TESTING AND  
MAINTENANCE

SEE SECTION 20.00  
FOR COATING  
REQUIREMENTS.

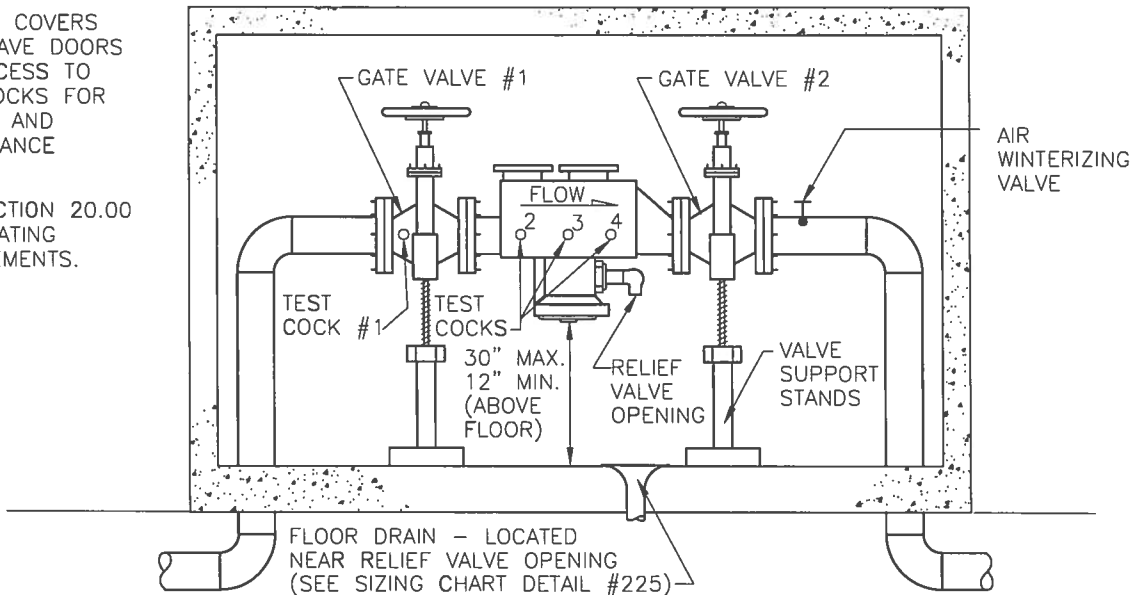

TYPICAL INSTALLATION OF REDUCE  
PRESSURE PRINCIPLE DEVICE (OUTSIDE)

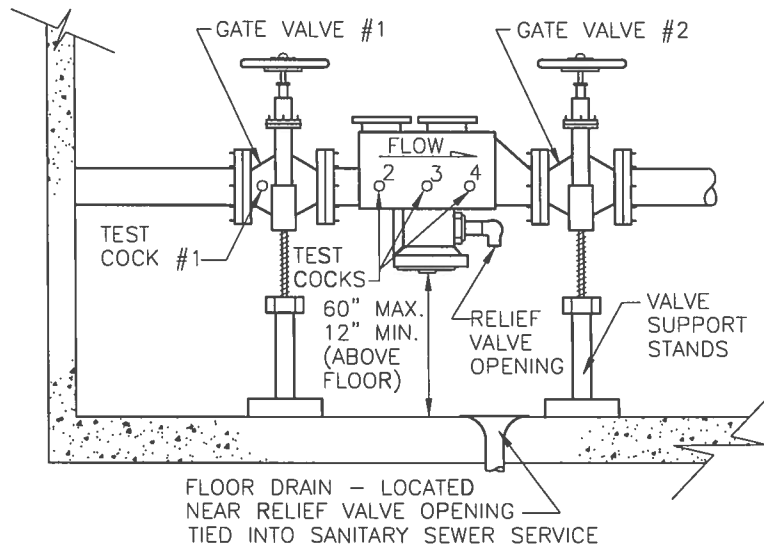

TYPICAL INSTALLATION OF REDUCE  
PRESSURE PRINCIPLE DEVICE (IN BUILDING)

DRAFT STANDARDS UTIL - STD 226

*AT*  
*1/23/12*  
*Ken Weyman* 2-6-12  
 CITY ENGINEER DATE  
*Chris J. ...* 2/6/12  
 AURORA WATER DATE

**BACKFLOW PREVENTION  
TYPICAL INSTALLATION**

**226**

STANDARD

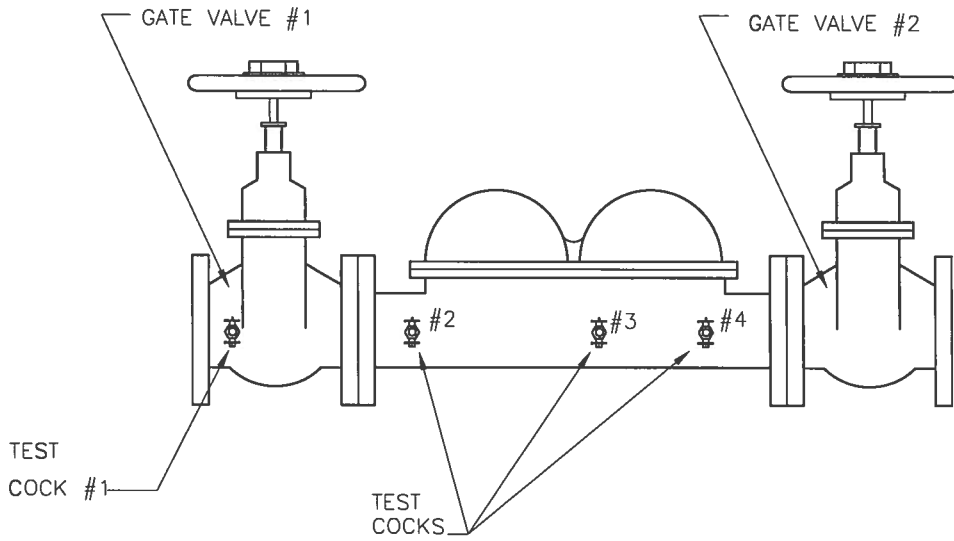

TYPICAL DOUBLE CHECK VALVE ASSEMBLY  
FIRE LINES ONLY

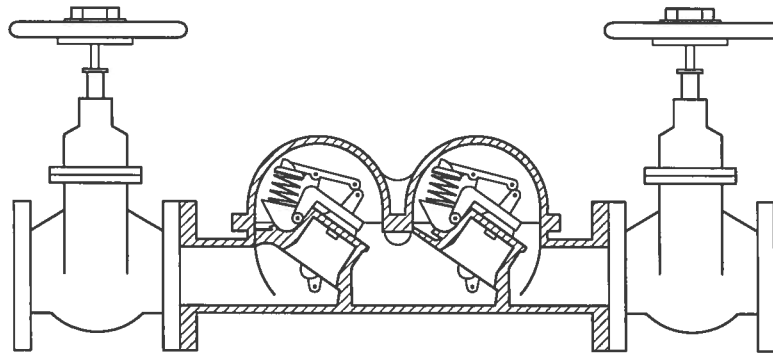

DRAFT STANDARDS (UTL-STD) 227

*11/2/12*  
*Kevin Wegener* 2-6-12  
CITY ENGINEER DATE  
*Chris* 2/8/12  
AURORA WATER DATE

TYPICAL DOUBLE CHECK  
VALVE ASSEMBLY

227

STANDARD

IRRIGATION SYSTEMS  
NOT SUBJECT TO BACKPRESSURE

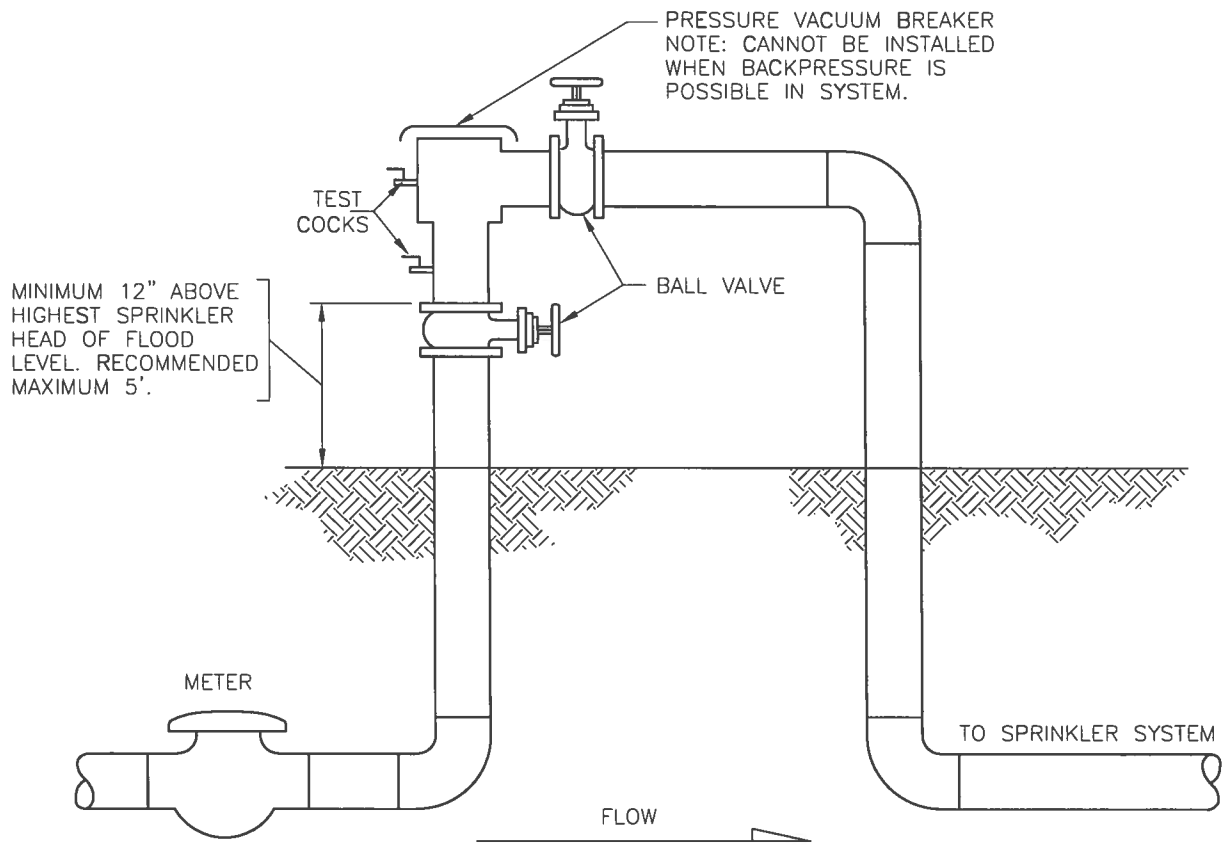

DRAFT STANDARD\UTL-STD\228-1

*2/25/12*  
*Karin Weymer* 2-6-12  
CITY ENGINEER DATE  
*Chris 2/8/12*  
AURORA WATER DATE

IRRIGATION SYSTEMS  
PRESSURE TYPE VACUUM  
BREAKER INSTALLATION

1 of 3  
228



# STANDARD

## TYPICAL PRESSURE TYPE VACUUM BREAKER

1. PRESSURE VACUUM BREAKERS SHOULD BE INSTALLED A MINIMUM OF 12" ABOVE THE HIGHEST OUTLET THEY ARE PROTECTING, BUT NO MORE THAN 5 FEET ABOVE GROUND.
2. PRESSURE VACUUM BREAKERS MAY BE INSTALLED UNDER CONTINUOUS LINE PRESSURE FOR LIMITED PERIODS OF TIME.
3. THE PRESSURE VACUUM BREAKER CANNOT BE INSTALLED WHERE THERE CAN BE BACKPRESSURE ANYWHERE DOWNSTREAM OF DEVICE.

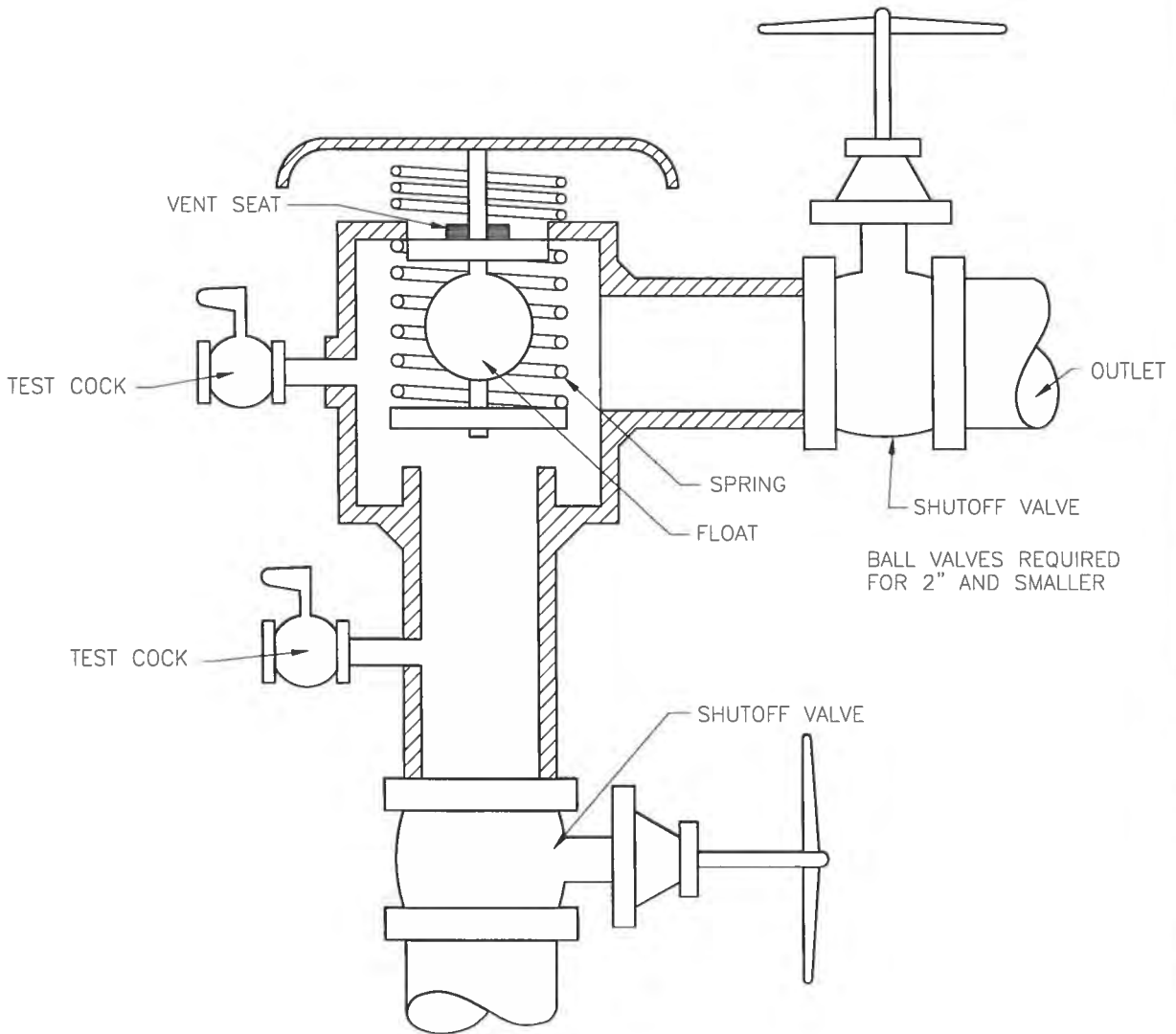

DRAFT STANDARDS \UTL-STD\ 228-2

*1/23/12*  
*Klein Wegner* 2-6-12  
CITY ENGINEER DATE  
*Chris 2/8/12*  
AURORA WATER DATE

**PRESSURE TYPE  
VACUUM BREAKER**

2 of 3  
**228**

# STANDARD

## INSTALLATION REQUIRED FOR CONTINUOUS SERVICE (TOP VIEW)

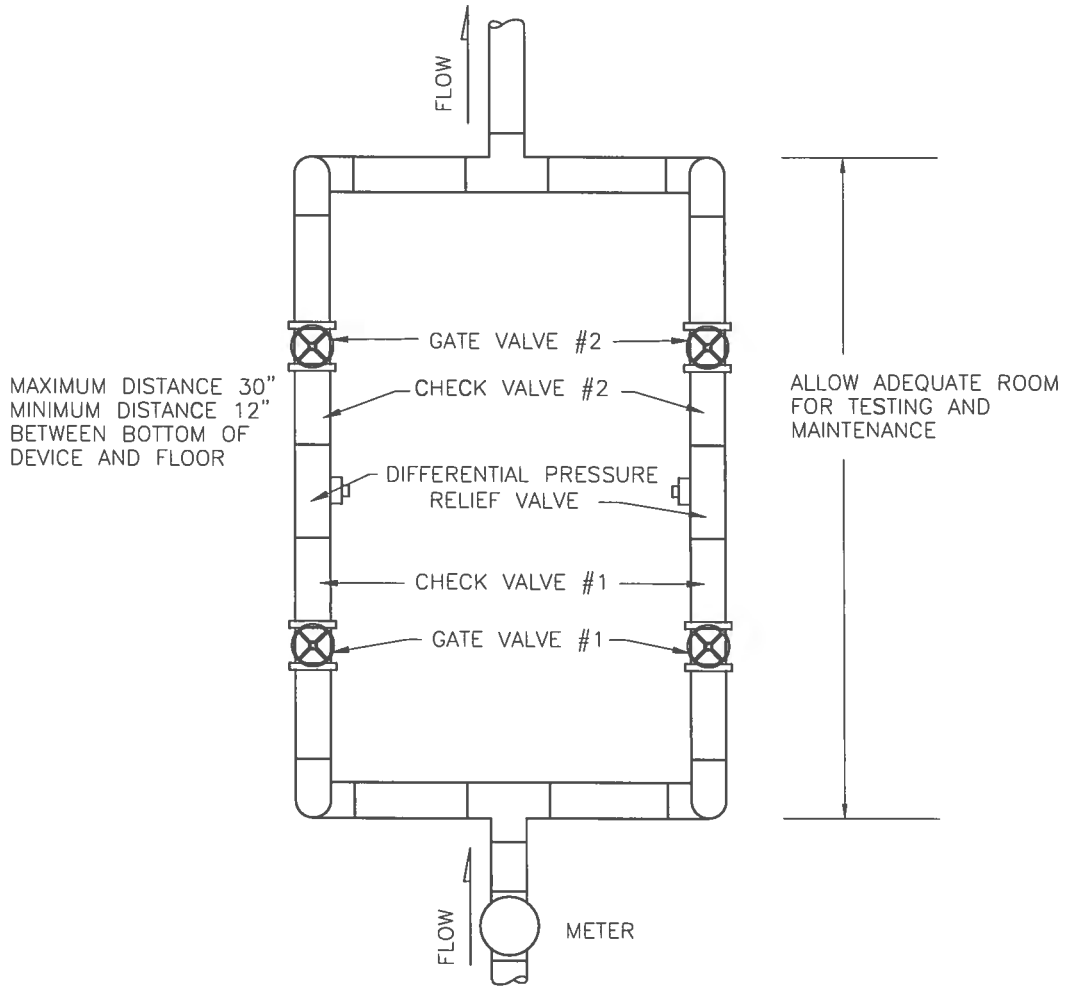

### NOTES:

1. WHEN DEVICES ARE UNCOVERED THEY WILL BE SECURED BY A CHAIN AND PADLOCK BETWEEN THE TWO GATE VALVES IF IN AN OPEN BAY OR ROOM.

DRAFT STANDARDS \UTL-STD\228-3

1/25/12  
Kevin W. Jensen  
CITY ENGINEER

2-6-12  
DATE

City 2/8/12  
AURORA WATER

2/8/12  
DATE

INSTALLATION REQUIRED  
FOR CONTINUOUS SERVICE

3 of 3

228

# STANDARD

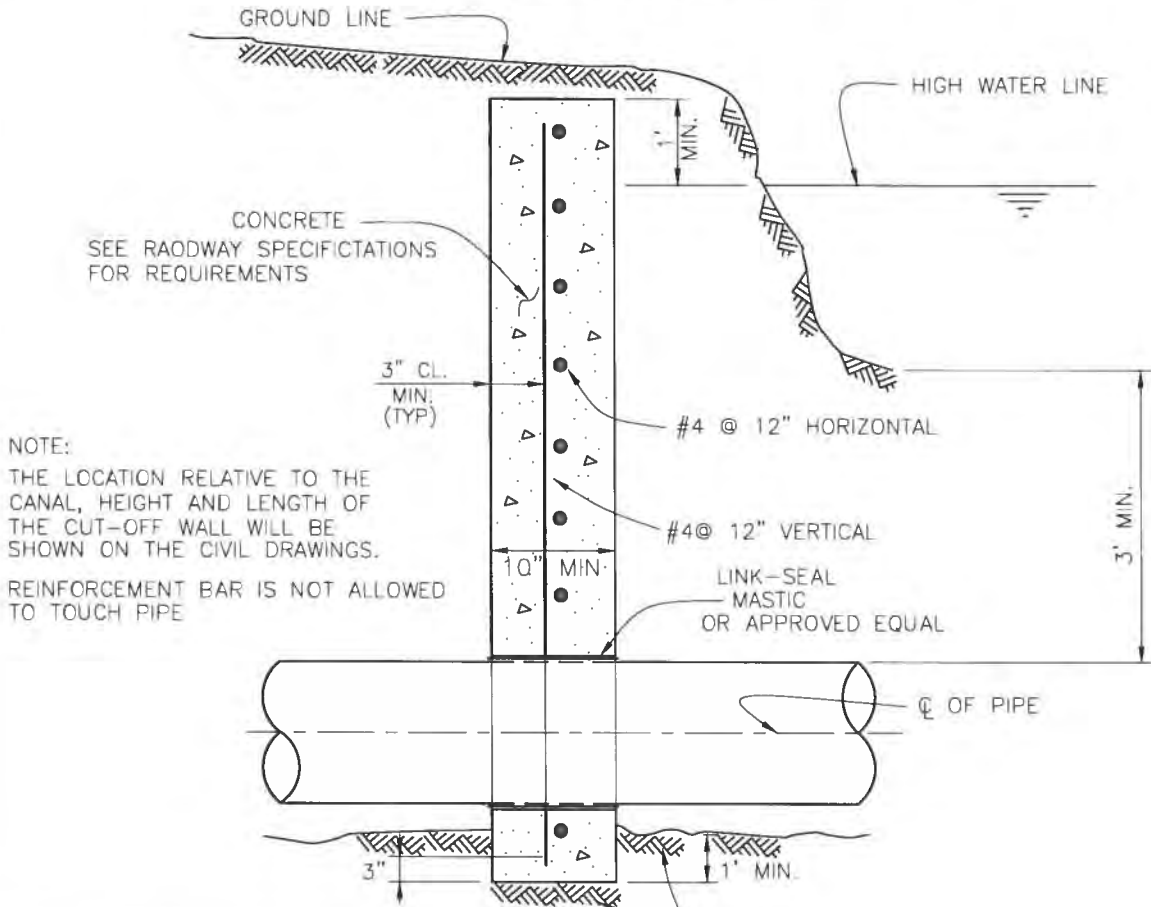

SIDE VIEW

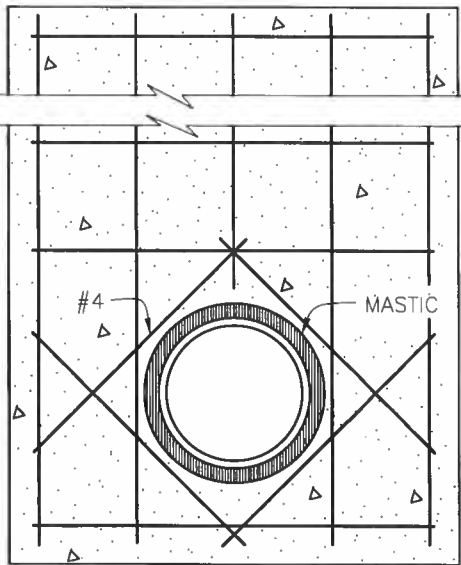

FRONT VIEW

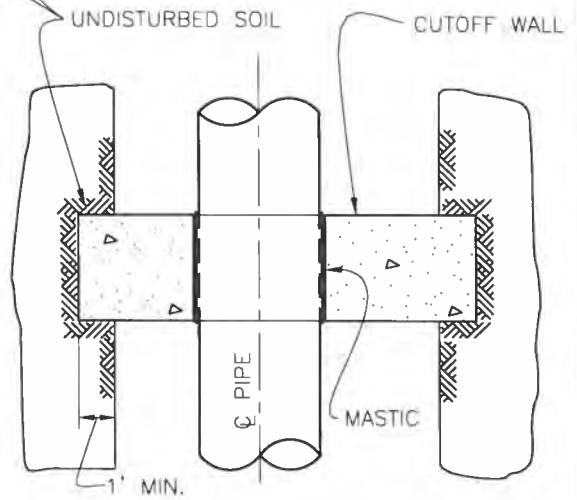

TOP VIEW

NOTE:  
REINFORCEMENT NOT SHOWN.

DRAFT STANDARDS UTIL - STD 229

*KL*  
2/6/12  
*Kevin Weymer* 2-6-12  
CITY ENGINEER DATE

*Chris St* 2/8/12  
AURORA WATER DATE

TYPICAL CUT-OFF WALL  
FOR DITCH OR CANAL  
CROSSING

229

# STANDARD

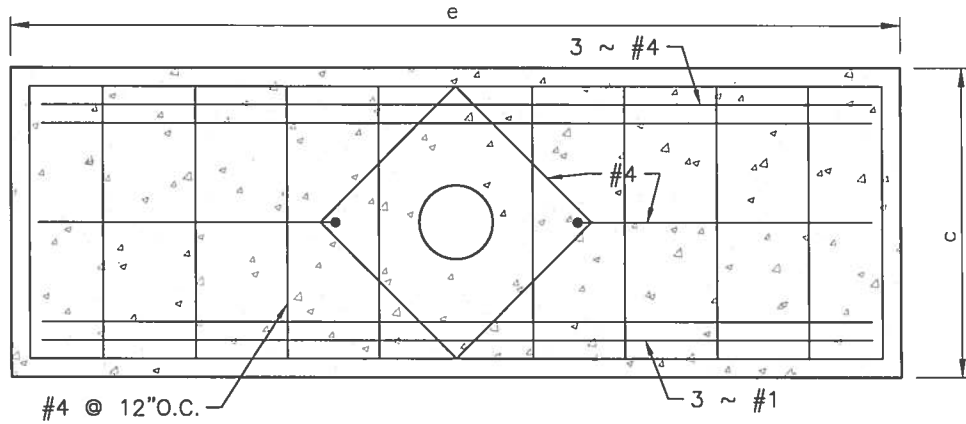
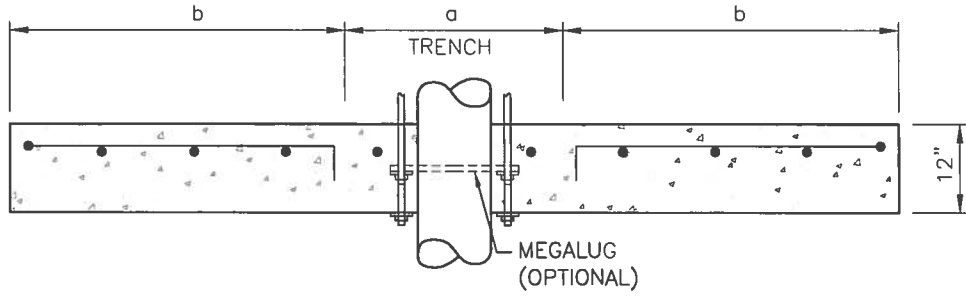

TIE ROD DIAMETERS	
D	ROD
4"	2 ~ 3/4"
6"	2 ~ 3/4"
8"	2 ~ 3/4"
12"	2 ~ 1" OR 4 ~ 3/4"
16"	4 ~ 7/8"
24"	4 ~ 1-1/8"

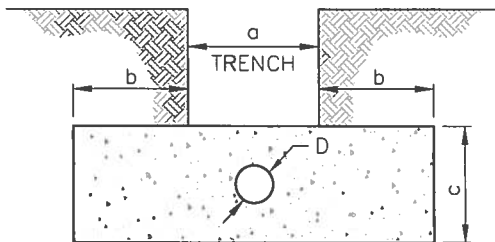
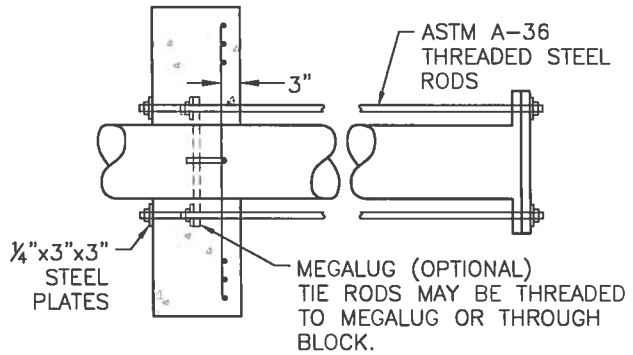

D	a	b	c	e
4"	20"	12"	28"	44"
6"	22"	12"	32"	46"
8"	24"	18"	38"	60"
12"	32"	30"	44"	92"
16"	36"	60"	42"	156"
24"	40"	73"	64"	186"

DRAFT STANDARDS UTIL - STD \ 230

*1/25/12*  
*Kevin Weyman* 2-6-12  
 CITY ENGINEER DATE  
*Clayton* 2/8/12  
 AURORA WATER DATE

INLINE ANCHOR

230

# STANDARD

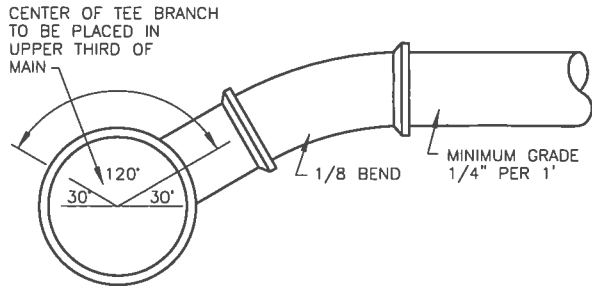

**1/8 BEND CONNECTION TO TEE**

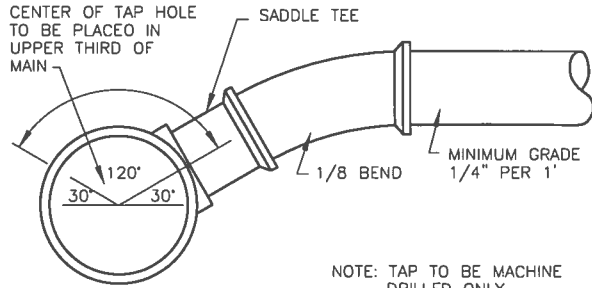

**1/8 BEND & SADDLE CONNECTION**

NOTE: TAP TO BE MACHINE DRILLED ONLY

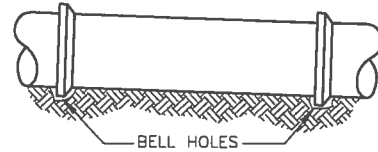

**ACCEPTABLE BENDING**

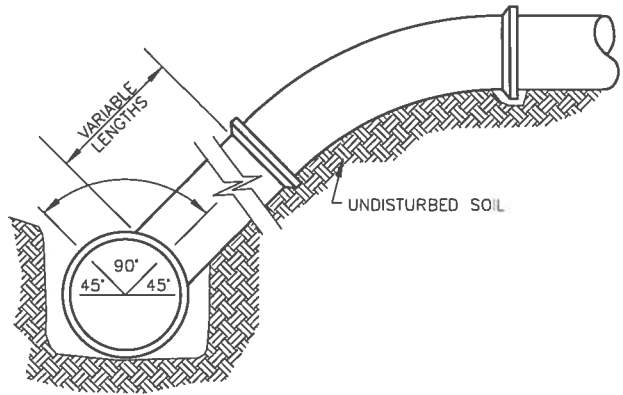

**RISER DETAIL  
FOR SEWERS OVER 15' DEEP**

**NOTES:**

1. BELLS SHALL NOT TOUCH THE SIDES OR THE BOTTOM OF THE BELL HOLE.
2. THE BARREL SECTION SHALL BE SUPPORTED THROUGHOUT ITS LENGTH.
3. SERVICE TAPS SHALL BE IN LINE TEE OR MACHINE TAPPED. HAND TAPS SHALL NOT BE ALLOWED.
4. SERVICE LINES SHALL BE LOCATED 5' DOWNHILL FROM CENTERLINE OF LOT.
5. THE CURB SHALL BE MARKED WITH 'S' WHERE THE SEWER SERVICE LINE CROSSES THE CURB.
6. MINIMUM SERVICE LINES GRADES  
     4" SERVICE LATERALS @ 2%  
     6" SERVICE LATERALS @ 0.62%
7. JOINTS SHALL BE WATER TIGHT.

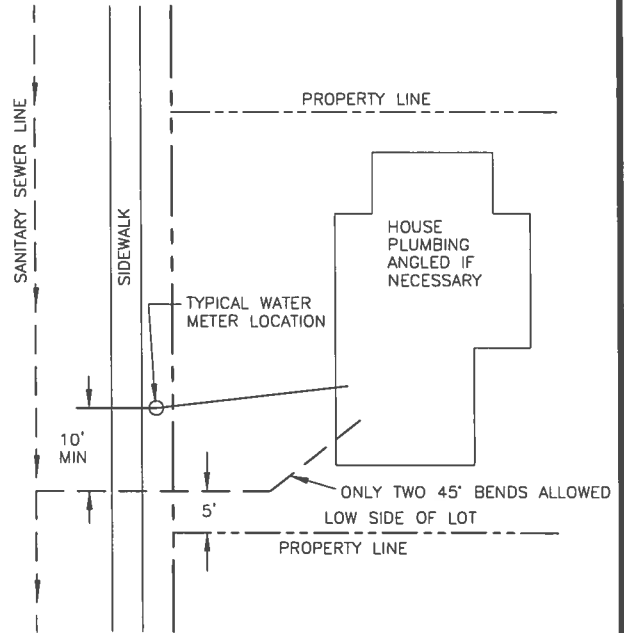

**RESIDENTIAL SEWER SERVICE**

DRAFT STANDARDS UTIL - STD 300

11/23/12  
*Kevin Wiegner* 2-6-12  
 CITY ENGINEER DATE  
*Chris J. St...* 2/8/12  
 AURORA WATER DATE

**SANITARY SEWER  
SERVICE DETAIL**

**300**

# STANDARD

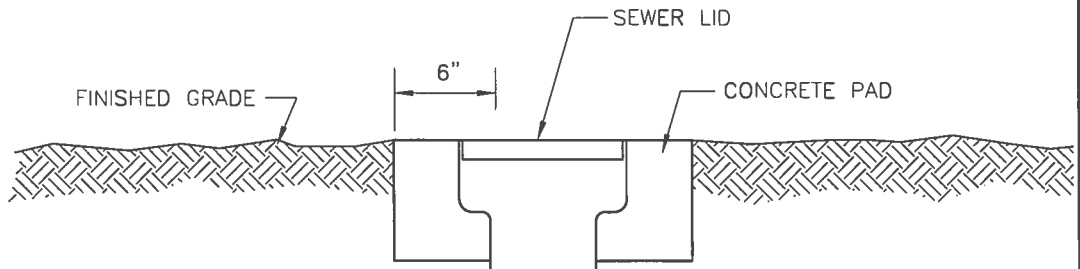

## NOTES:

1. CLEAN-OUT SHALL BE CONSTRUCTED SO THAT THE SURFACE LOAD WILL NOT BE TRANSFERRED TO THE MAIN.
2. CONCRETE PAD SHALL BE INSTALLED SO THAT THE WATER WILL RUN AWAY FROM THE INSTALLATION.
3. WHENEVER POSSIBLE, LOCATE CLEAN-OUTS WITHIN LANDSCAPED AREAS.

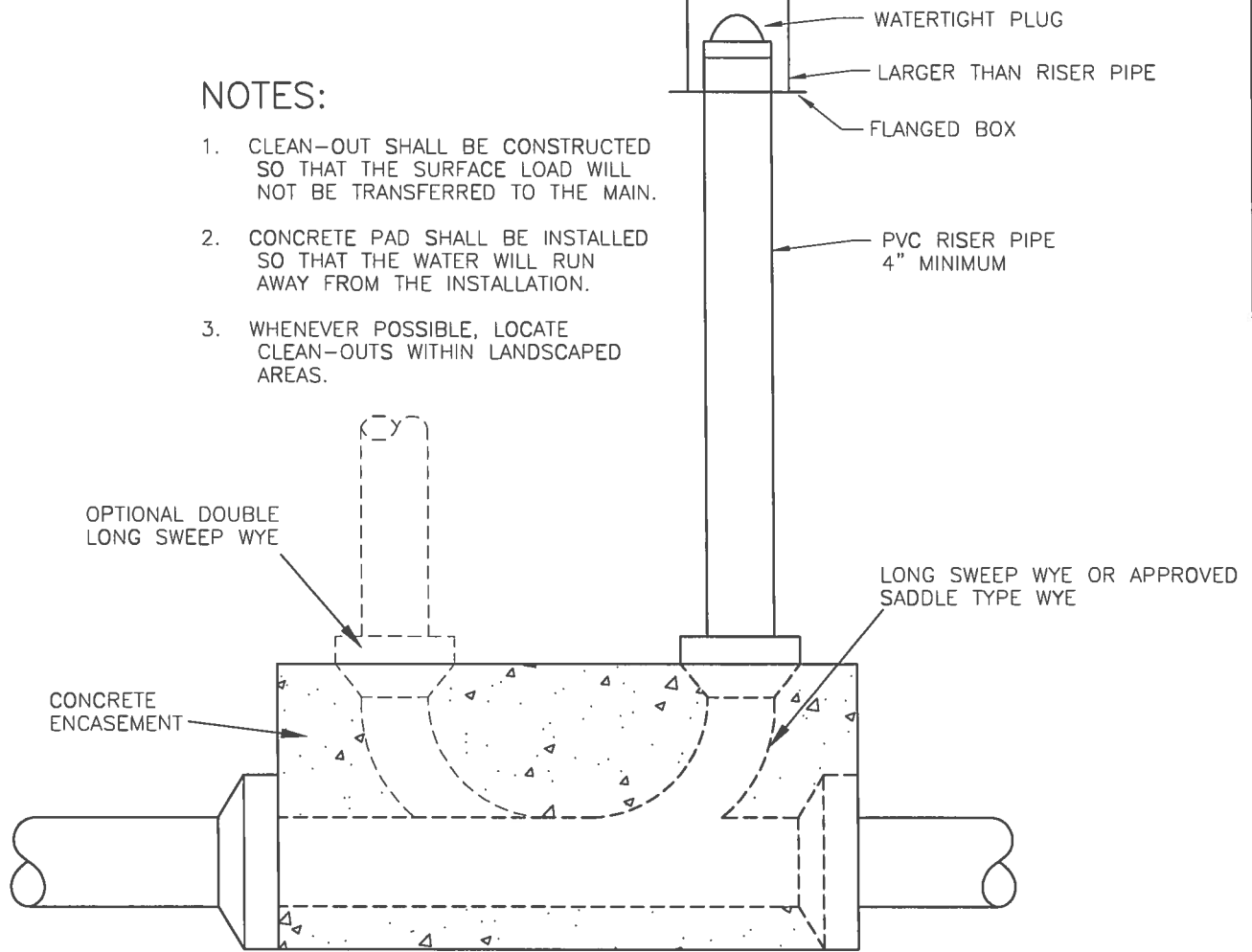

DRAFT STANDARDS UTIL-STD\301

*Ken Weyen* 2-6-12  
 CITY ENGINEER DATE  
*Clay 28th* 2/6/12  
 AURORA WATER DATE

**SANITARY SEWER  
 CLEANOUT  
 (PRIVATE ONLY)**

**301**

# STANDARD

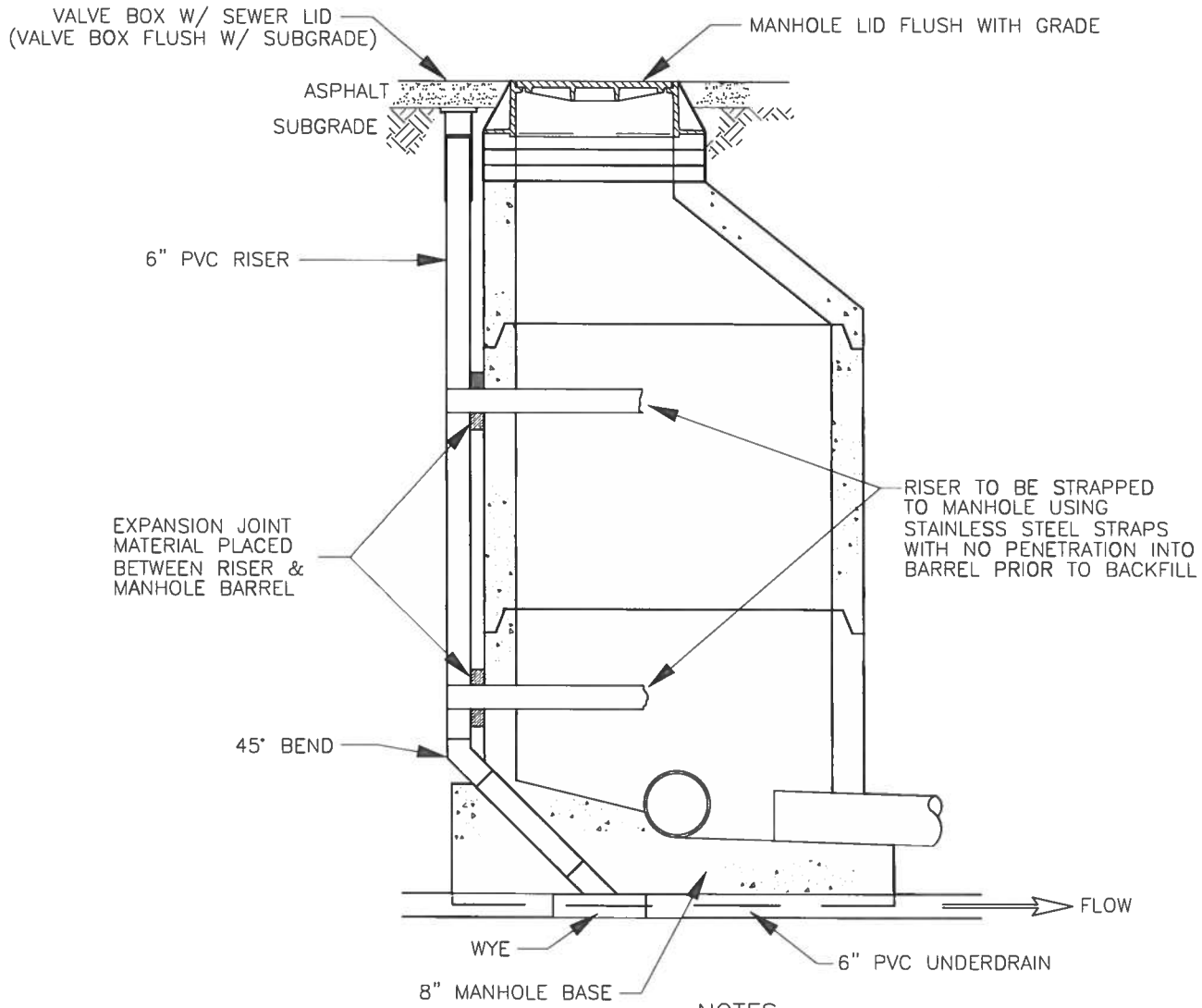

### NOTES

1. PIPE SHALL BE NON-PERFORATED WITHIN 5 FEET OF SANITARY SEWER MANHOLES.
2. PIPE SHALL BE WRAPPED WITH MIRAFI FABRIC SO THAT SOIL CANNOT INFILTRATE THE UNDERDRAIN SYSTEM.

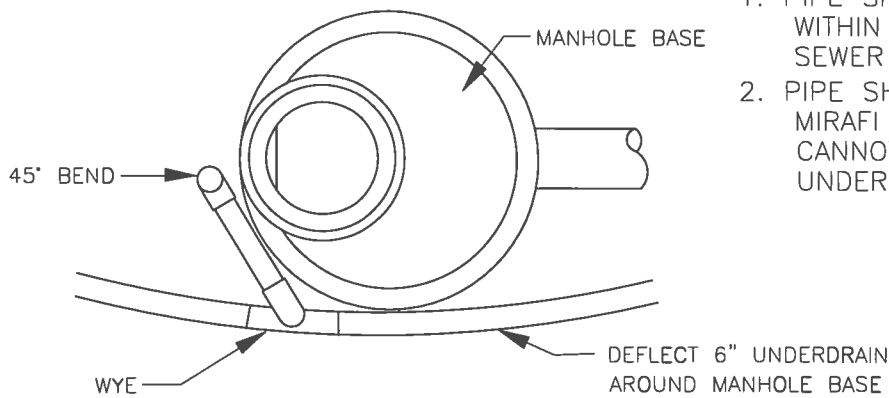

DRAFT STANDARDS UTIL-STD\302

*KE*  
1/23/12  
*Kevin Wegener* 2-6-12  
CITY ENGINEER DATE  
*Chris Z...* 2/8/12  
AURORA WATER DATE

**PRIVATE UNDERDRAIN  
CLEAN-OUT CONNECTION**

**302**

# STANDARD

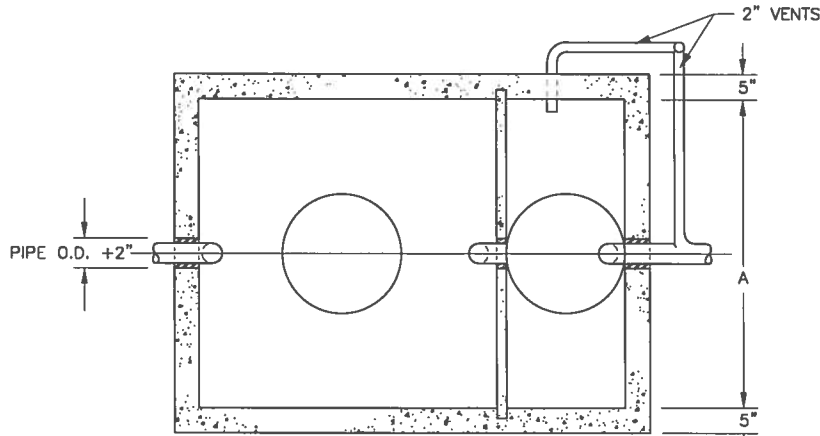

PLAN

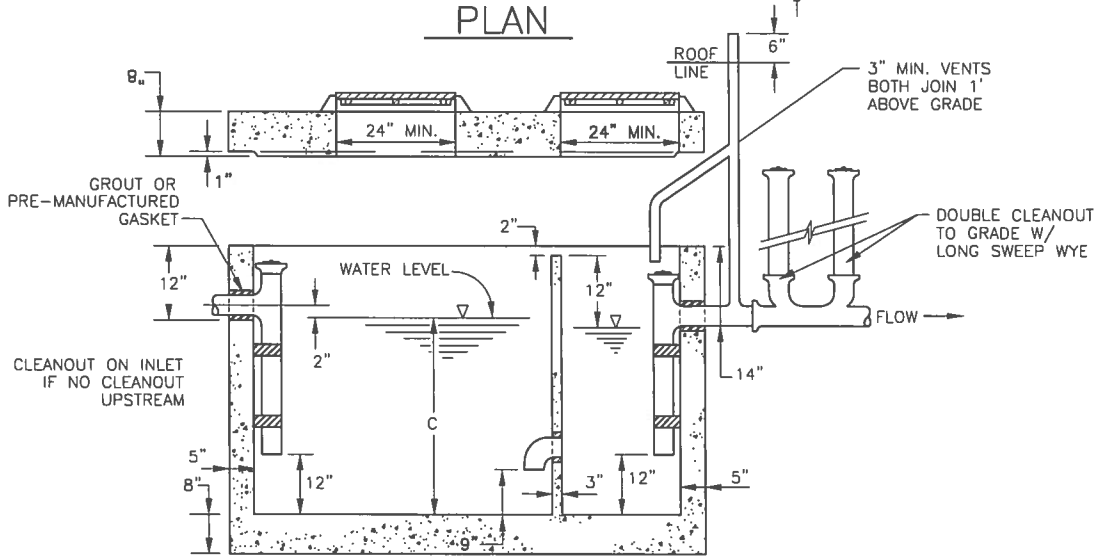

SECTION

1. SECONDARY TANK TO BE 1/3 OF TOTAL VOLUME.
2. BAFFLE WALL INSERTS TO BE SEALED IN PLACE.
3. OUTLET PIPE INVERT TO BE 2" LOWER THAN INLET.
4. SUPPORT BRACKETS AND CLEAN-OUT CAPS SHALL BE GALVANIZED STEEL.
5. TANK AND LID TO BE TRAFFIC RATED (Hs-20 LOADING)
6. MANHOLE COVERS AND CLEAN-OUT CAPS MUST NOT FALL BELOW GRADE.
7. MANHOLE RING & COVER SHALL BE NEENAH R-1706, OR APPROVED EQUAL.
8. ALL JOINTS IN PRECAST JOINT SECTIONS TO BE SEALED RAMNEK.
9. ALL PIPING TO BE DUCTILE IRON OR SCHEDULE 40 PVC WITH A MINIMUM DIAMETER OF 4" UNLESS OTHERWISE NOTED.
10. NO BOLT DOWN COVERS ALLOWED WITHOUT WRITTEN AUTHORIZATION FROM AURORA WATER ENGINEERING.
11. VENT PIPES SHALL BE CAST IRON OR SCHEDULE 40 PVC AND CAN JOIN TOGETHER AT 1" ABOVE GRADE.
12. INLET AND OUTLET RISER PIPES LONGER THAN 12" SHALL BE ANCHORED TO WALL AT 4" BELOW PIPE OPENING.
13. SEE APPENDIX C FOR ADDITIONAL WASTEWATER CONTROL REGULATIONS.

**STANDARD ACCEPTED TANK SIZES (GALLONS)**

800  
1000  
1500  
2000  
2500  
3000

LARGER SIZES BY SPECIAL DESIGN  
APPROVED BY AURORA WATER ENGINEERING

DRAFT STANDARD/LTL-STD-303

1/25/12  
*Kevin Wegener* 2-6-12  
CITY ENGINEER DATE  
*Chris ZGA* 2/8/12  
AURORA WATER DATE

**RECOMMENDED  
GREASE INTERCEPTOR**

**303**



# STANDARD

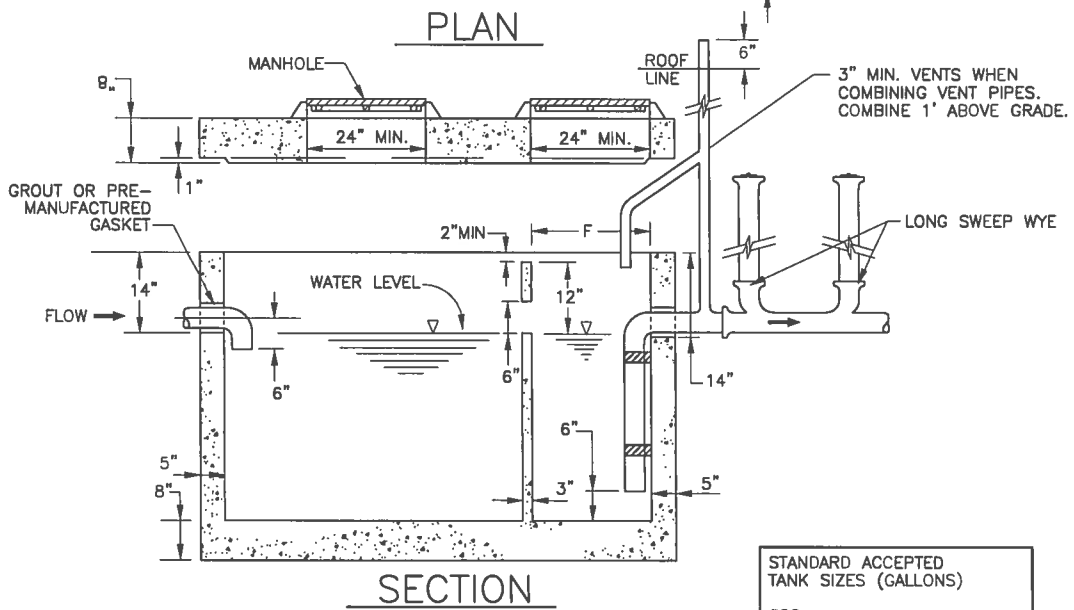
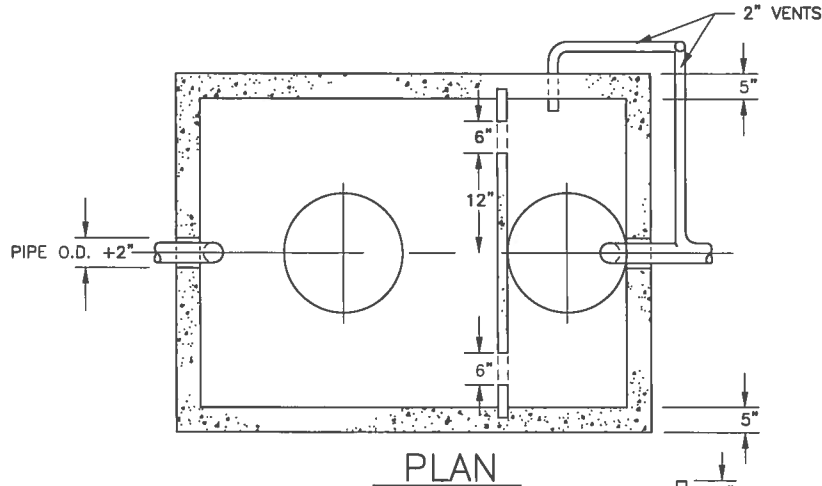

STANDARD ACCEPTED TANK SIZES (GALLONS)	
320	
500	
800	
1000	
1500	
2000	
2500	
3000	
LARGER BY SPECIAL DESIGN APPROVED BY AURORA WATER ENGINEERING	

1. ALL PIPE AND FITTINGS ARE TO BE SCHEDULE 40 PVC OR DUCTILE IRON. MINIMUM 4" DIAMETER.
2. SMALL COMPARTMENT HAS 1/3 TOTAL CAPACITY.
3. TANK AND LID TO BE TRAFFIC RATED (Hs-20 LOADING)
4. MANHOLE RING & COVER SHALL BE NEENAH R-1706, OR APPROVED EQUAL.
5. NO BOLT DOWN COVERS ALLOWED WITHOUT WRITTEN AUTHORIZATION FROM AURORA WATER ENGINEERING.  
SEE APPENDIX C FOR ADDITIONAL WASTEWATER CONTROL REGULATIONS
6. ALL JOINTS TO BE SEALED WITH RAMNEK.

DRAFT STANDARDS UTIL-STD-304

*Kevin Wegener* 2-6-12  
 CITY ENGINEER DATE  
*Chris J. Ste...* 2/8/12  
 AURORA WATER DATE

**RECOMMENDED  
SAND & OIL INTERCEPTOR  
TYPE 'A' COMMERCIAL**

**304**

# STANDARD

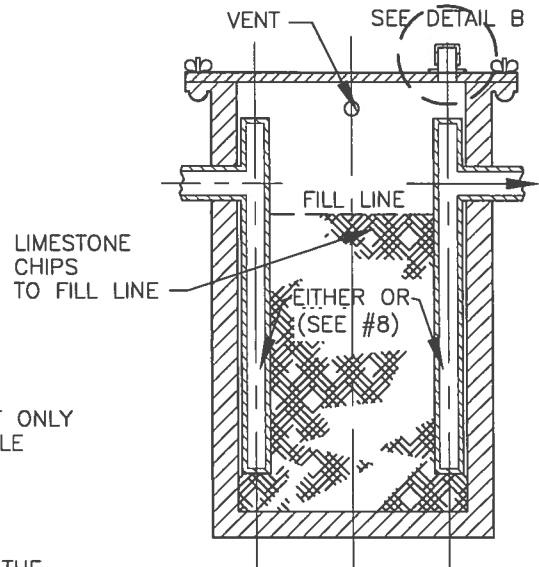
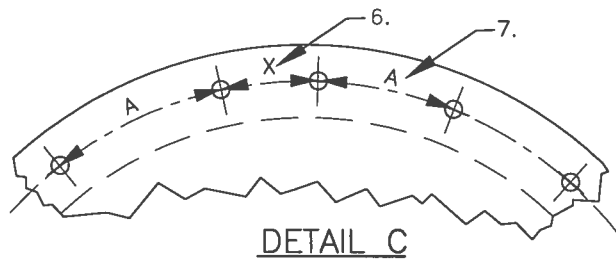
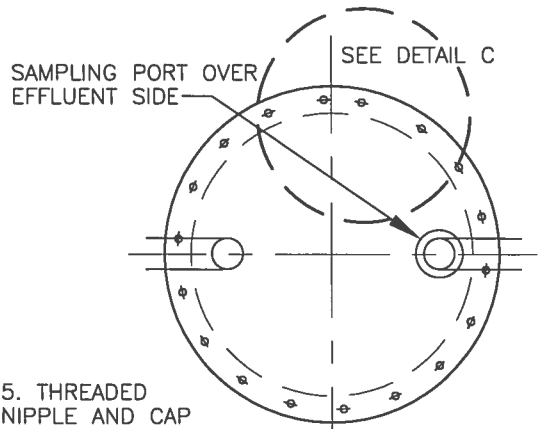
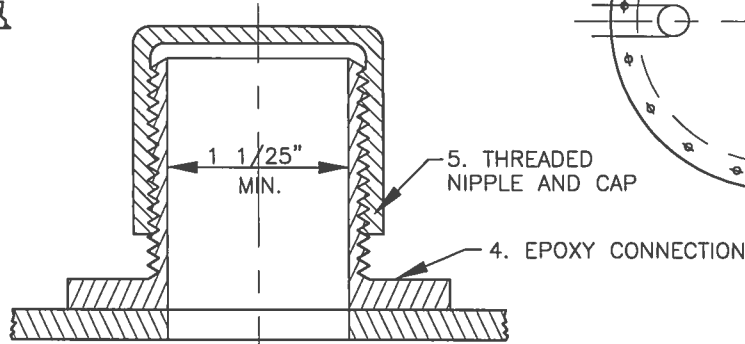
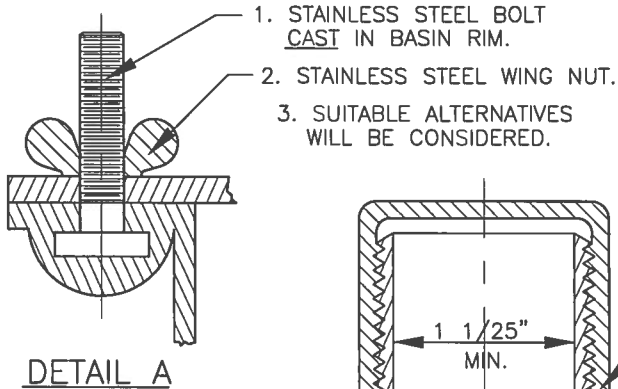

6. INTERVAL "X" PROVIDES A KEY SO THAT COVER WILL FIT ONLY WHEN SAMPLING PORT IS IN CORRECT POSITION. SUITABLE ALTERNATIVES WILL BE CONSIDERED.
7. ALL OTHER INTERVALS ARE "A".
8. MOST MANUFACTURERS WILL PLACE THE RISER TO SUIT THE NEEDS OF THE CUSTOMER. THE RISER MUST BE IN ONE LOCATION OR THE OTHER - NOT BOTH.
9. ALL UNITS MUST BE INSTALLED SO THEY ARE EASILY ACCESSIBLE FOR MAINTENANCE AND TESTING.
10. WHERE A UNIT IS TO BE LOCATED UNDERGROUND A CONCRETE VAULT WITH HATCH ACCESS MUST BE PROVIDED AND SAMPLING PORT MUST BE EXTENDED TO A POINT NO LESS THAN 6" AND NO MORE THAN 12" BELOW THE LEVEL OF THE FINISHED FLOOR OR GROUND.
11. MATERIALS - SPECIFIC MATERIALS MUST BE SELECTED FOR SPECIFIC APPLICATIONS.  
HIGH DENSITY POLYETHYLENE AND POLYPROPYLENE MATERIALS ARE RECOMMENDED IN MOST CASES  
CONCRETE UNITS LINED WITH "ACID RESISTANT" MATERIAL WILL NOT BE APPROVED.
12. ACID NEUTRALIZATION TANKS AND INSTALLATIONS THERE OF MUST BE INSPECTED AND APPROVED BY AURORA WATER ENGINEERING.
13. SEE APPENDIX C FOR ADDITIONAL WASTEWATER CONTROL REGULATIONS.

DRAFT STANDARDS UTIL - STD 305

1/23/12  
*Kevin Helgeson* 2-6-12  
 CITY ENGINEER DATE  
*Chris J. Ste...* 2/8/12  
 AURORA WATER DATE

**RECOMMENDED  
ACID NEUTRALIZATION  
UNIT**

**305**

# STANDARD

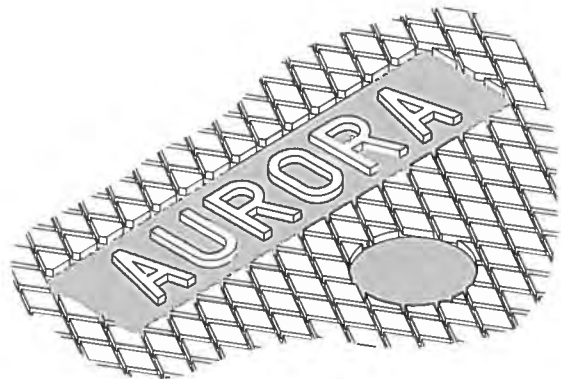
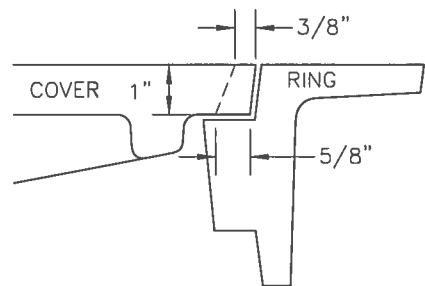
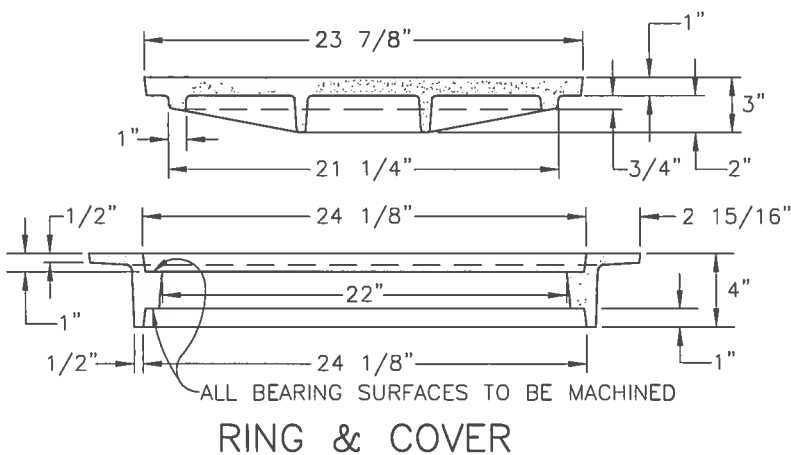
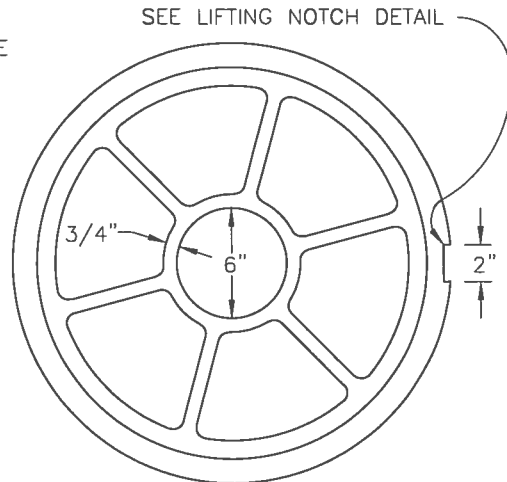
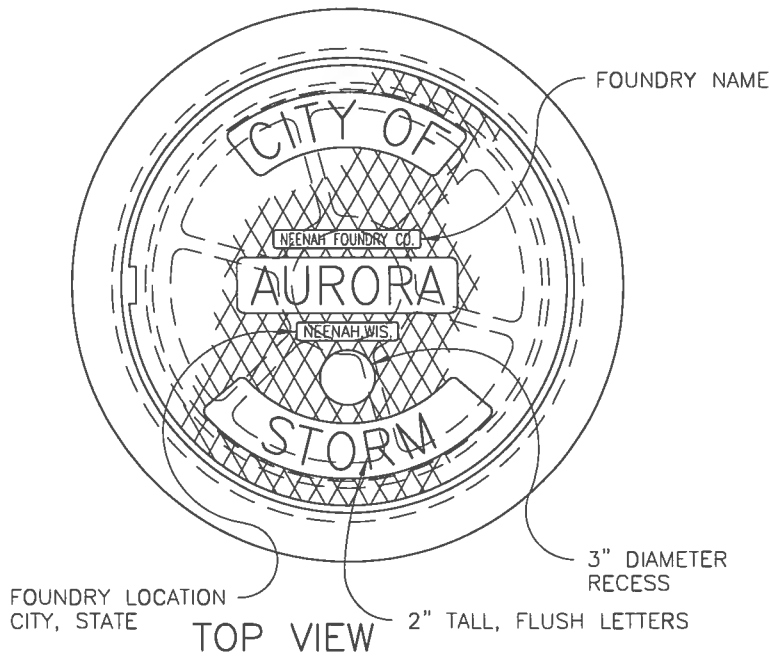

TYPE "C" DESIGN: 1" X 1" SCORED 1/32"± DEEP

**NOTES:**

1. A.S.T.M. DESIGNATION A-48-83 CLASS 35B (UNPAINTED).
2. ALL BEARING SURFACES TO BE MACHINED.
3. LETTERING ON COVER AS REQUIRED (STORM).
4. TOTAL MINIMUM WEIGHT APPROXIMATELY 272 LBS.
5. AURORA STANDARD-NEENAH R-1706-1S, OR EQUAL.
6. LIFTING NOTCH SHALL NOT EXTEND PAST INSIDE FACE OF RING SEAT.
7. MINIMUM FRAME WEIGHT-114 LBS; MINIMUM LID WEIGHT-158 LBS.

DRAFT STANDARDS UTIL-STD 400-1

1/23/12  
*Kenn Wegener* 2-6-12  
 CITY ENGINEER DATE

*Chris 28th* 2/8/12  
 AURORA WATER DATE

**24" TYPE R INLET  
RING & COVER**

1 of 9  
**400**

# STANDARD

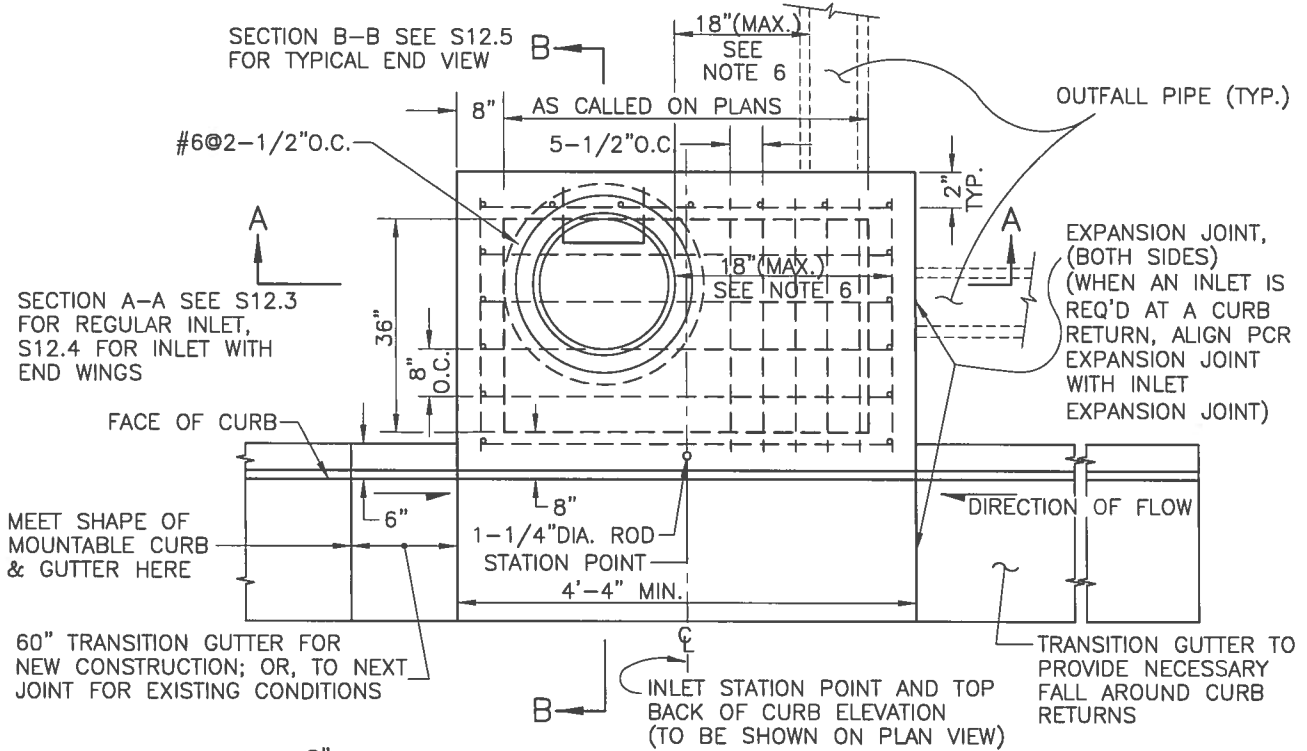

INLET RING & COVER TO CONFORM TO DETAIL 400-1

NOTE: CHANNEL AND ALL OTHER EXPOSED STEEL SHALL BE GALVANIZED (AASHTO M111). CHANNEL SHALL BE EXTENDED 5" INTO THE WALL ON EACH SIDE.

### BENDING DIAGRAM

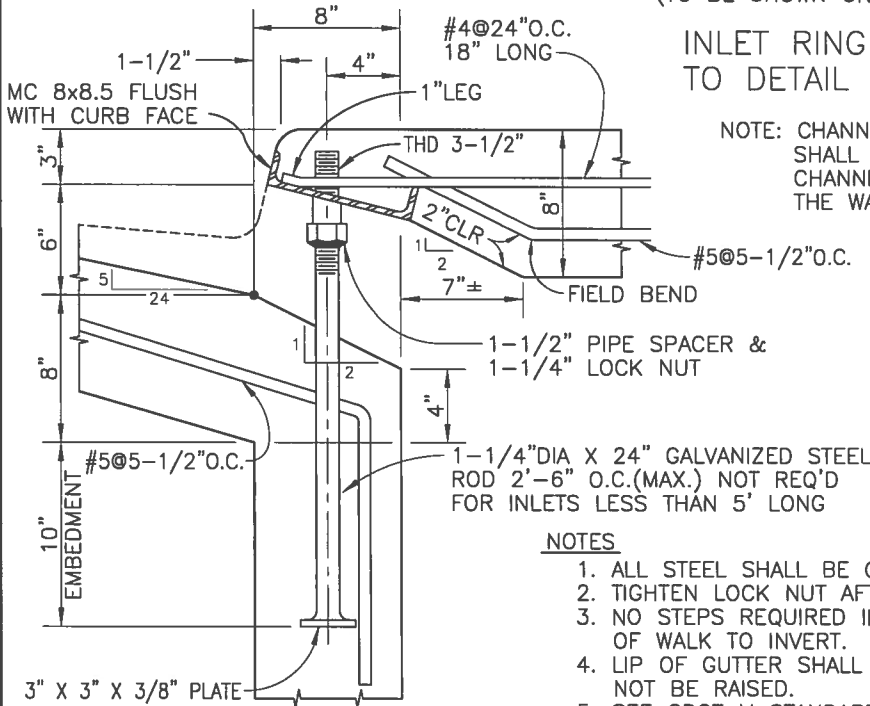
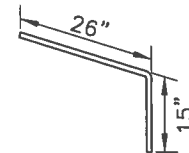

### CURB FACE ASSEMBLY

#### NOTES

1. ALL STEEL SHALL BE CAST IN PLACE.
2. TIGHTEN LOCK NUT AFTER TOP SLAB CURES.
3. NO STEPS REQUIRED IN INLETS LESS THAN 36" DEEP, TOP OF WALK TO INVERT.
4. LIP OF GUTTER SHALL NOT BE DIPPED, TOP OF BOX SHALL NOT BE RAISED.
5. SEE CDOT M STANDARDS FOR ALL INFORMATION NOT SHOWN ON THIS DRAWING.
6. EDGE OF ACCESS OPENING SHALL BE LOCATED NO MORE THAN 18" FROM THE INSIDE FACE OF THE OUTFALL PIPE.
7. FOR ON GRADE INLETS, THE DECK TOP SHALL MATCH THE STREET GRADE.
8. INLETS OVER 10 FEET IN LENGTH REQUIRE TWO ACCESS OPENINGS.

DRAFT STANDARDS VJL-STD\400-2

*Kevin Weyner*  
 CITY ENGINEER      DATE 2-6-12

*Chris Ste*  
 AURORA WATER      DATE 2/8/12

**CURB OPENING INLET  
TYPE "R" MODIFIED**

2 of 9

400

# STANDARD

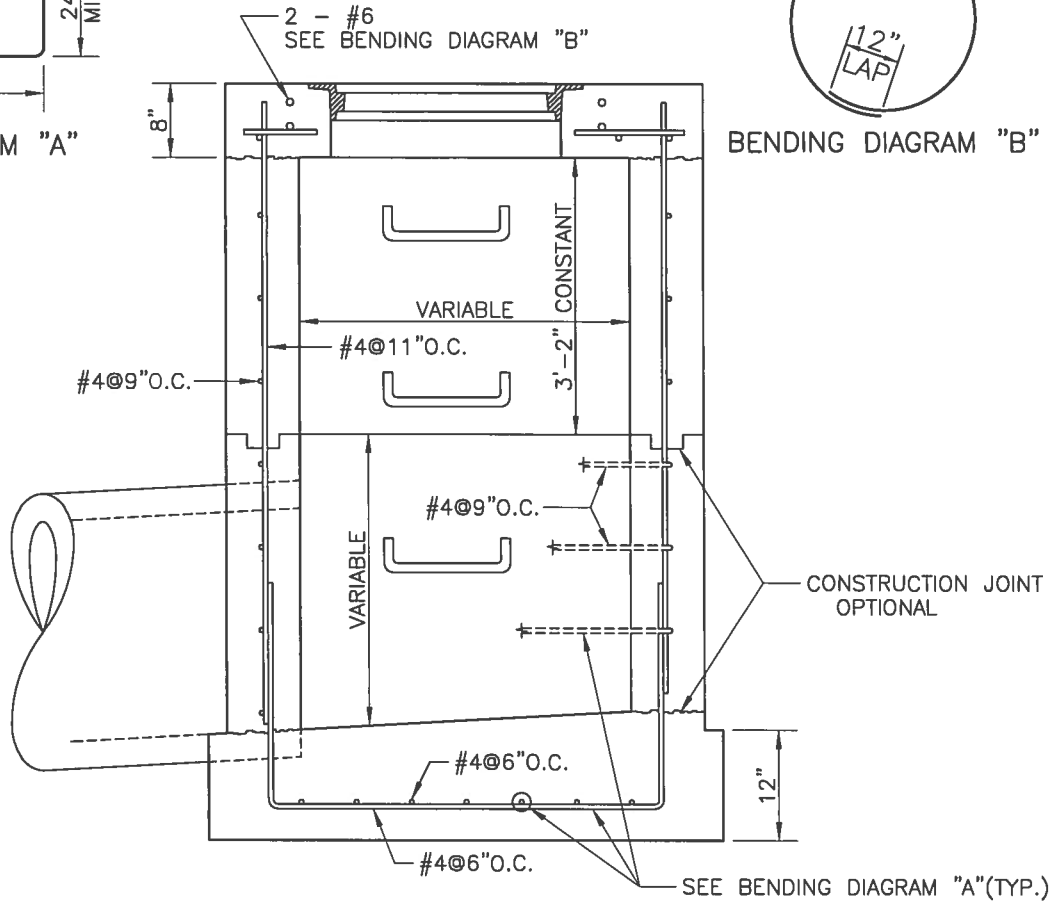
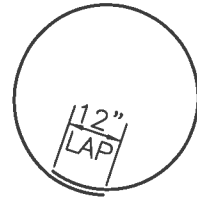
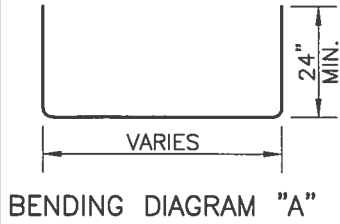

**SECTION A-A  
REGULAR INLET  
NOT TO SCALE**

NOTE:  
ALL CONSTRUCTION JOINTS  
SHALL HAVE A 2" X 4" KEYWAY.

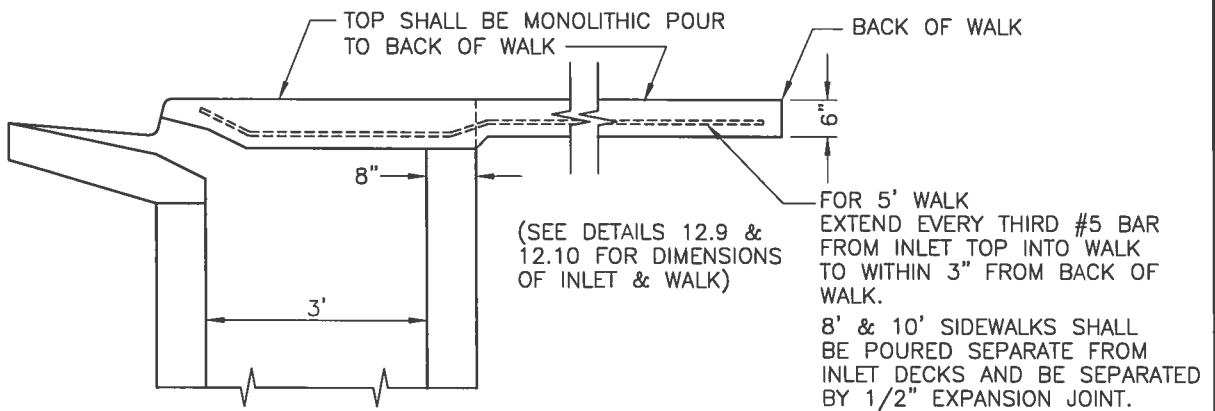

DRAFT STANDARD UTL-STD\400-3

*Kevin Wegener* 7-6-12  
CITY ENGINEER DATE

*Chris Str* 2/8/12  
AURORA WATER DATE

**CURB OPENING INLET  
TYPE "R" MODIFIED**

3 of 9

**400**

# STANDARD

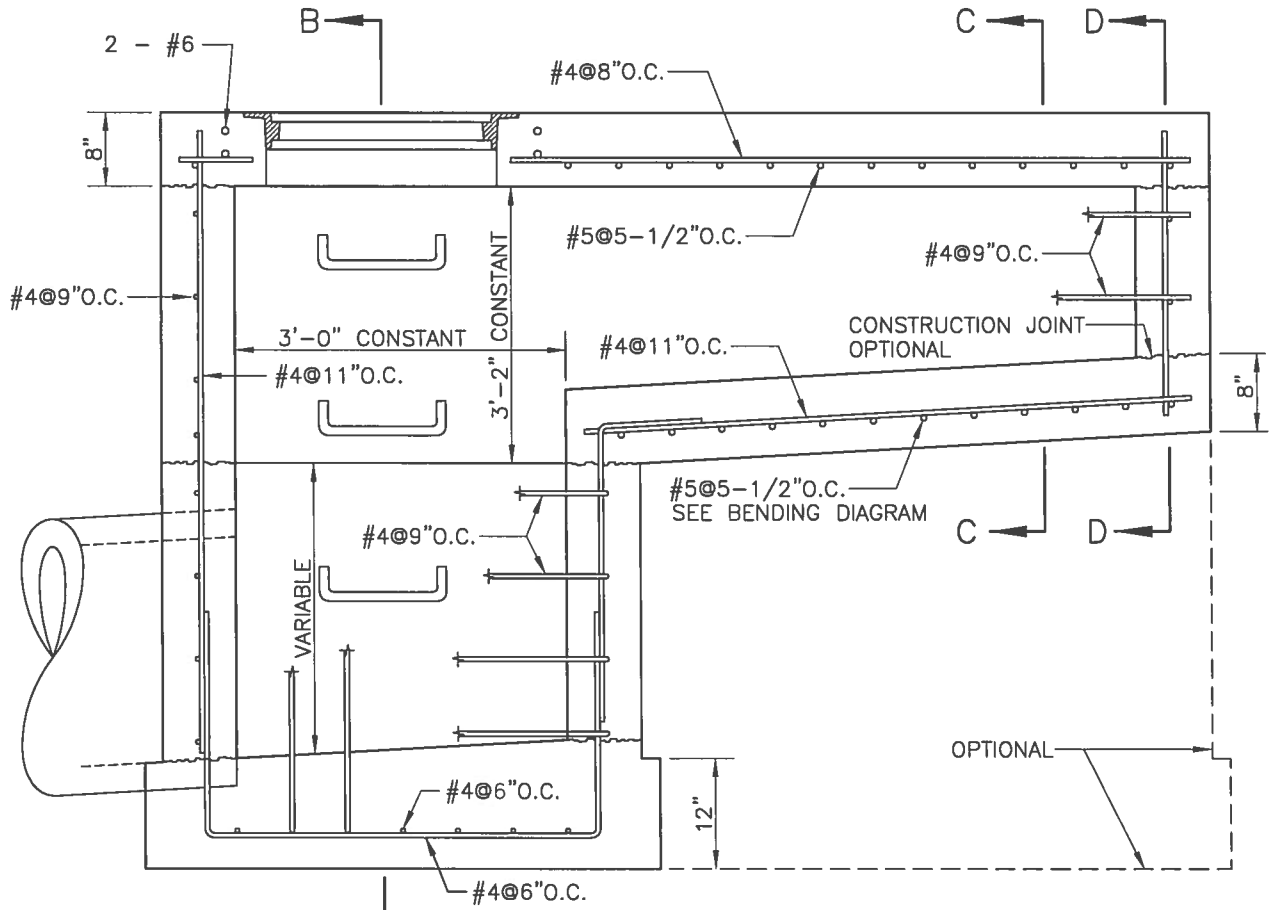

SECTION A-A

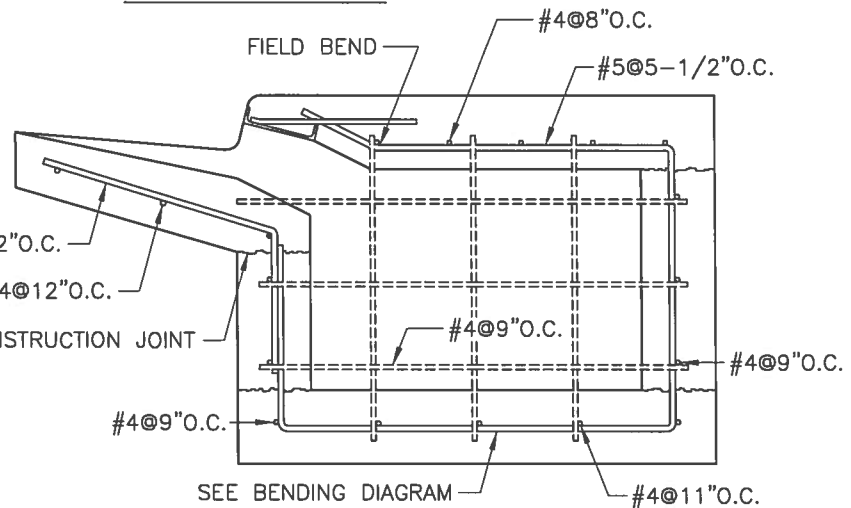

SECTION C-C & D-D  
(DOTTED BARS ARE IN SECTION D-D)

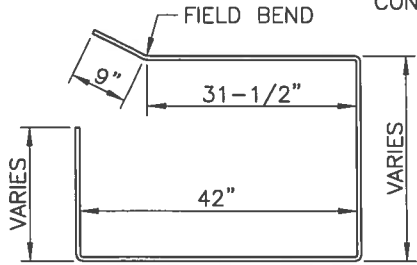

BENDING DIAGRAM

DRAFT STANDARDS\UTL-STD\400-4

#2/12  
 Kevin Wegener 2-6-12  
 CITY ENGINEER DATE  
 Chris Str 2/8/12  
 AURORA WATER DATE

CURB OPENING INLET  
TYPE "R" MODIFIED

4 of 9  
400

# STANDARD

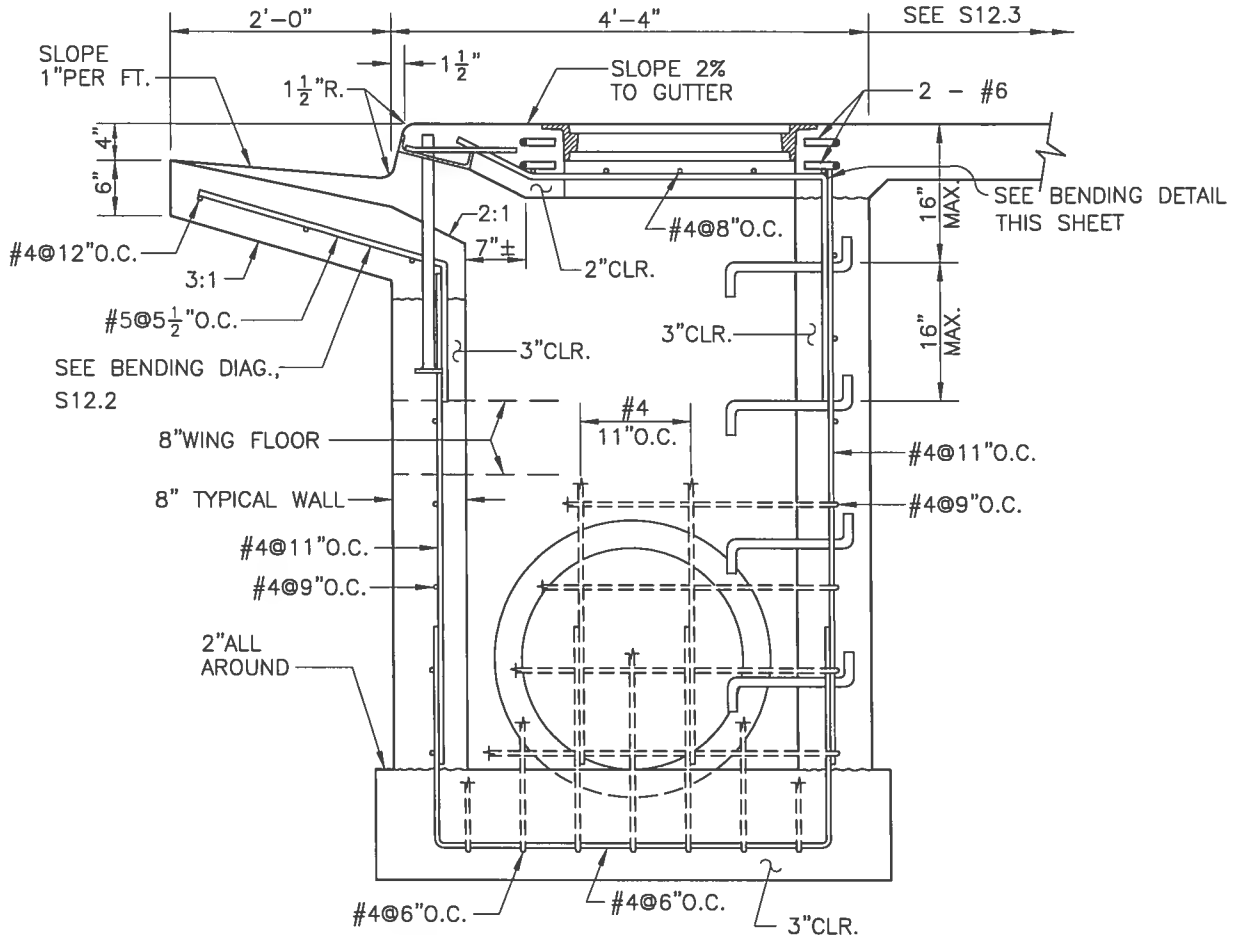

SECTION B-B  
TYPICAL END VIEW

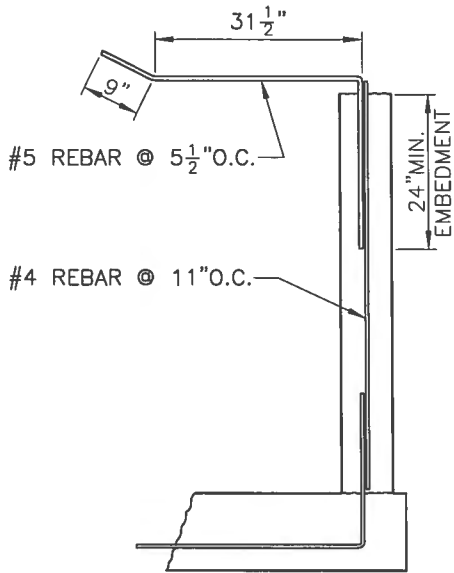

BENDING DETAIL

INLET RING AND COVER TO CONFORM TO  
DETAIL 400-1

STEPS SHALL BE AS SPECIFIED IN  
DETAILS 105 AND 106 OF CITY OF  
AURORA PUBLIC UTILITY IMPROVEMENTS  
RULES AND REGULATIONS REGARDING  
STANDARDS AND SPECIFICATIONS: WATER,  
SANITARY, STORM SEWER.

ALL #4 REBAR SHALL BE GRADE 40.

ALL #5 AND LARGER REBAR SHALL BE  
GRADE 60.

DRAFT STANDARDS UTIL-STD\400-5

11/23/12  
*Kevin Wever* 2-6-12  
 CITY ENGINEER DATE  
*Chris J. Str...* 2/8/12  
 AURORA WATER DATE

**CURB OPENING INLET  
TYPE "R" MODIFIED**

5 of 9

**400**

# STANDARD

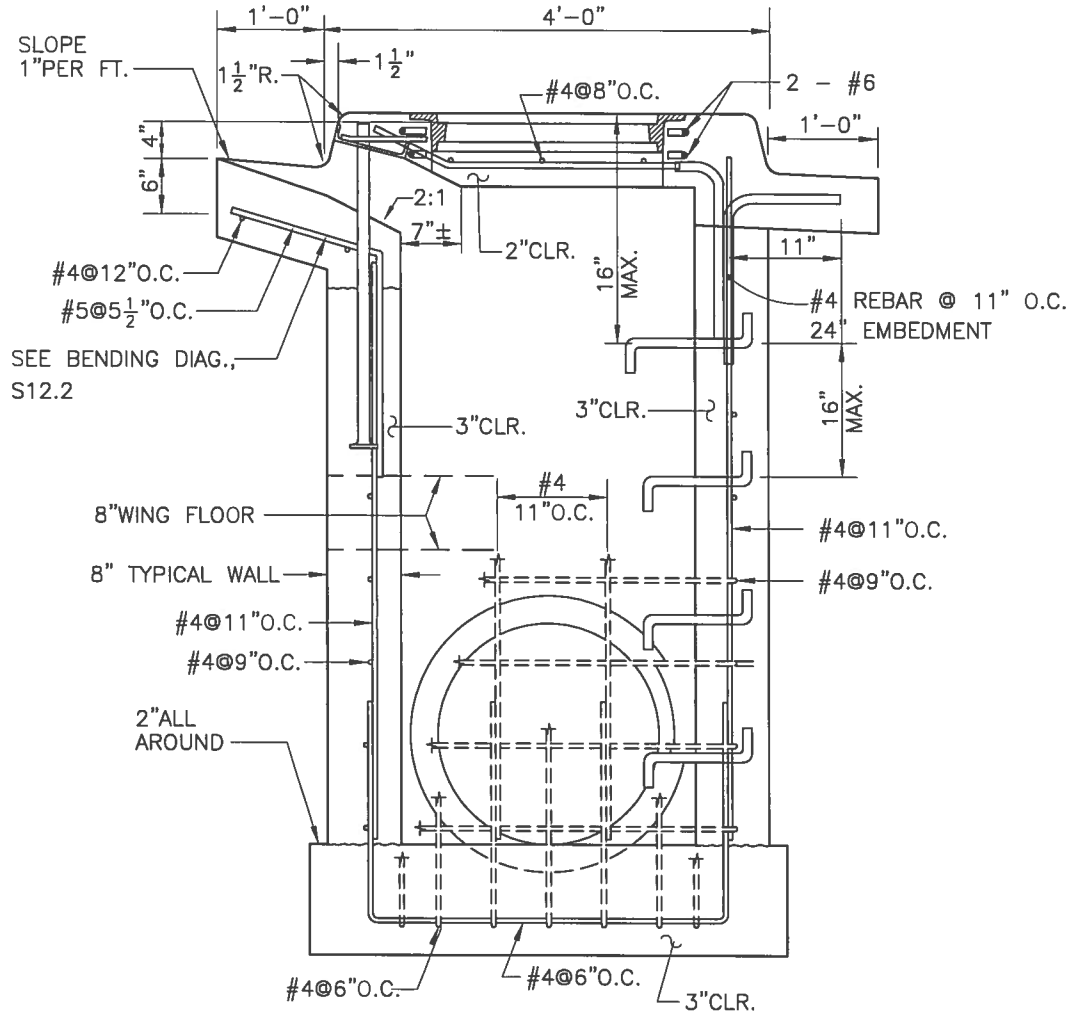

## TYPICAL END VIEW

REFER TO DETAIL 400-5  
FOR REINFORCING INFORMATION  
AND NOTES

DRAFT STANDARDS \UTL-STD\400-6

<p>2/6/12  <i>Kevin Wegener</i>                  CITY ENGINEER                  DATE</p>	<p>2-6-12                  DATE</p>
<p><i>Chris J. Str</i>                  AURORA WATER                  DATE</p>	<p>2/6/12                  DATE</p>

**CURB OPENING INLET  
TYPE "R" MODIFIED**

6 of 9

**400**



# STANDARD

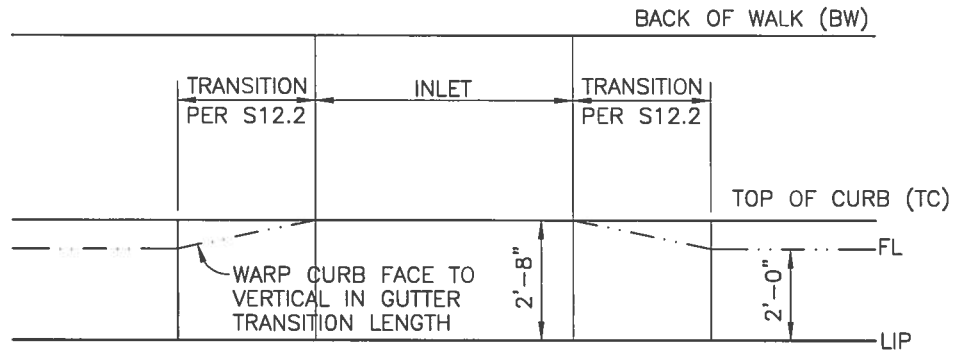

## PLAN

TRANSITION MOUNTABLE CURB & GUTTER TO CURB OPENING INLET

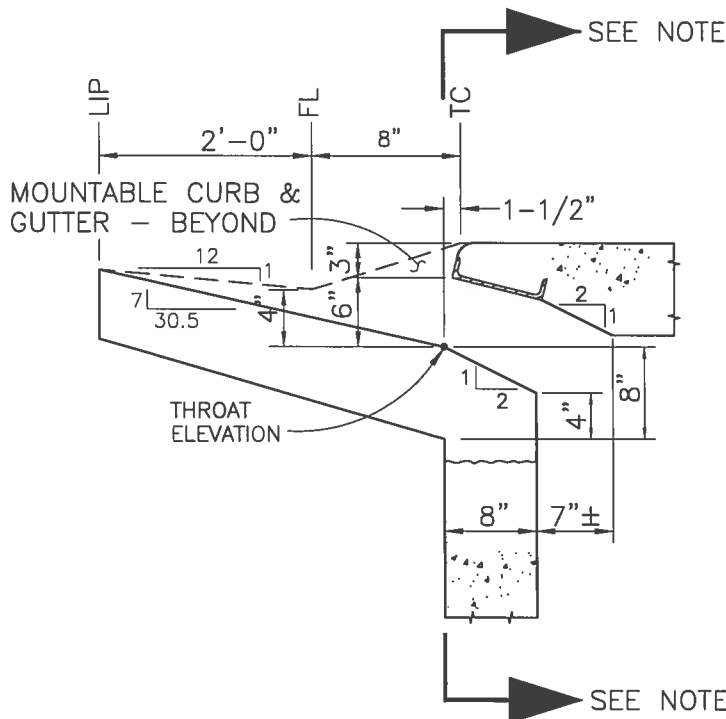

NOTE:  
ALL CONSTRUCTION THIS POINT BACK SHALL CONFORM TO S 400, 1 THRU 6 OF 11.

THROAT CONFIGURATION DETAIL  
CURB OPENING INLET WITH  
MOUNTABLE CURB & GUTTER

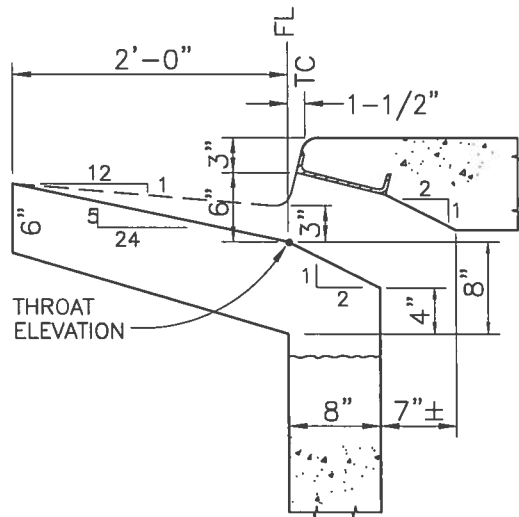

NOTE:  
REFER TO S 400, 1 THRU 6 OF 11 FOR COMPLETE CONSTRUCTION DETAILS.

THROAT CONFIGURATION DETAIL  
CURB OPENING INLET WITH  
VERTICAL CURB & GUTTER

DRAFT STANDARDS (UTL-STD) 400-7

*KS/12*  
Kevin Wegener 2-6-12  
CITY ENGINEER DATE  
Chris J. Str 2/6/12  
AURORA WATER DATE

**CURB OPENING INLET**  
**TYPE R MODIFIED**

7 of 9  
**400**

# STANDARD

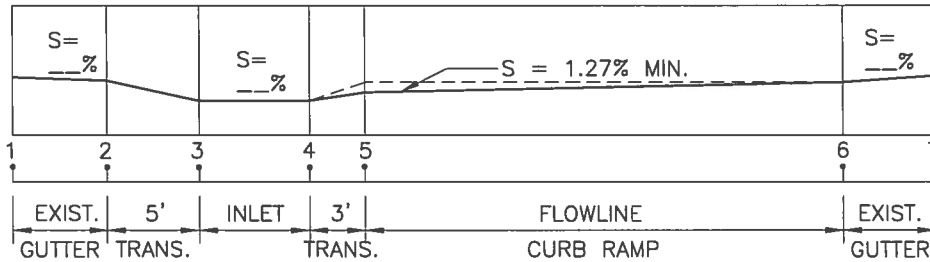
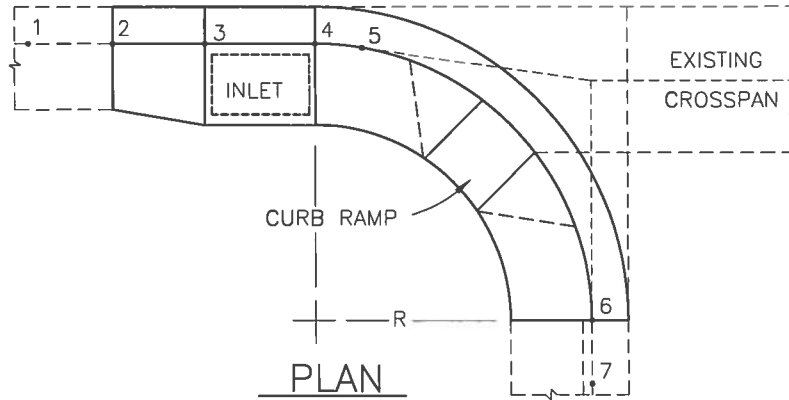

PROFILE

## DETAIL FOR MINIMUM SLOPE OF FLOWLINE ALONG CURB

FROM - TO	SLOPE DESCRIPTION
1 - 2	EXISTING OR CORRECTED SLOPE OF THE FLOWLINE
2 - 3	VERTICAL TRANSITION OF THE FLOWLINE
3 - 4	THE SLOPE OF THE FLOWLINE SHALL BE PARALLEL WITH THE STREET
4 - 5	TRANSITION OF THE SLOPE UP TO THE INTERSECTION WITH 1.27% SLOPE
5 - 6	MINIMUM SLOPE OF 1.27% ALONG CURB FLOWLINE
6 - 7	EXISTING OR CORRECTED SLOPE OF THE FLOWLINE

NOTE: FOR RETROFITTING WHERE REPLACING PREVIOUS INLET WITH NEW INLET

DRAFT STANDARDS UTIL-STD-400-8

*KW*  
*11/23/12*  
*Karin Weyener* 2-6-12  
 CITY ENGINEER DATE  
*Chris Zguta* 2/8/12  
 AURORA WATER DATE

**SPECIAL RETROFIT**  
**CURB OPENING INLET**  
**TYPE R MODIFIED**

8 of 9

400

# STANDARD

INLET DECK IS SHOWN WITHOUT CURB OPENING

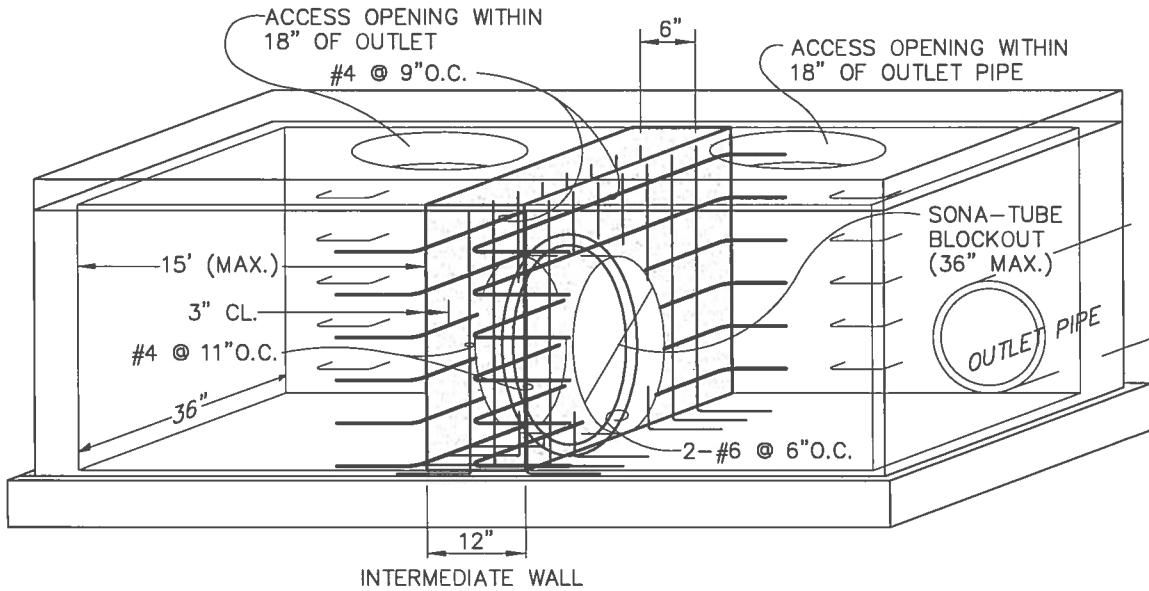

## NOTES

1. PROVIDE A 1 1/2" DEEP CONTROL JOINT THROUGH THE INLET DECK AT EACH INTERMEDIATE WALL PER S7.3 OF THE "ROADWAY DESIGN & CONSTRUCTION SPECIFICATIONS". THE JOINT SHALL EXTEND FROM THE BACK OF THE DECK TO THE FACE OF THE GUTTER PAN.
2. INLET DECK REINFORCEMENT STEEL SHALL BE CONTINUOUS WITH SPLICE LENGTHS OF NO LESS THAN 18". INTERMEDIATE WALL STEEL SHALL TIE INTO THE OUTSIDE WALLS AND FLOOR PER STANDARD DETAILS.
3. ALL INTERMEDIATE WALL CONSTRUCTION SHALL CONFORM TO STANDARD CONSTRUCTION SPECIFICATION AS SHOWN IN STANDARD DETAILS #400, 1 THRU 7 UNLESS OTHERWISE NOTED.

DRAFT STANDARDS UTIL - STD 400-9

2/6/12 <i>Kevin Weyner</i> CITY ENGINEER DATE	2-6-12 DATE
<i>Chris J. St.</i> AURORA WATER DATE	2/6/12 DATE

**TYPE 'R' INLET**  
(GREATER THAN 15' IN LENGTH)

9 of 9

**400**

STANDARD

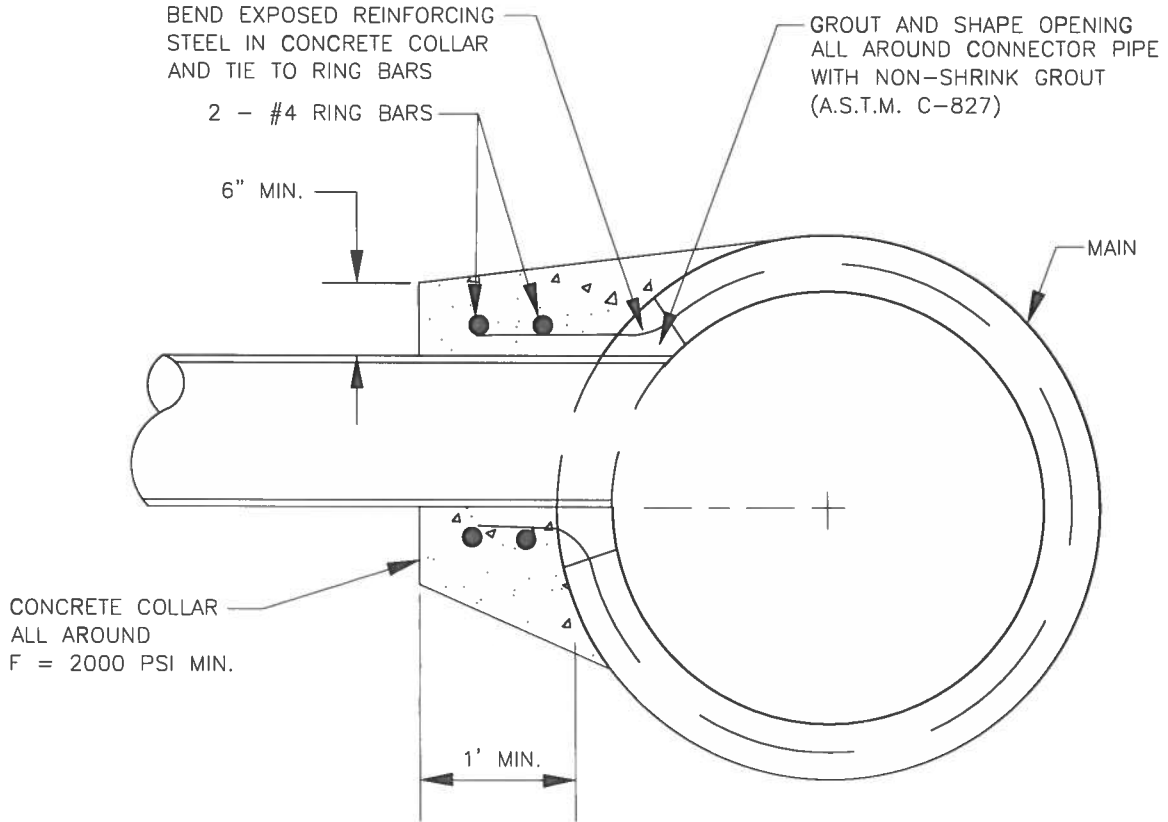

NOTE:

1. END OF PIPE SHALL NOT EXTEND PAST INSIDE WALL OF STORM SEWER PIPE.
2. THIS CONNECTION IS PERMISSABLE WHEN THE INSIDE DIAMETER OF THE CONNECTING PIPE IS LESS THAN ONE-HALF THE INSIDE DIAMETER OF THE MAIN. OTHERWISE, A MANHOLE IS REQUIRED PER DETAIL 102 AT THE POINT OF CONNECTION.
3. THE C.O.A. UTILITIES DEPT. RESERVES THE RIGHT TO REQUIRE A MANHOLE AT THE POINT OF CONNECTION WHEN DEEMED NECESSARY.

DRAFT STANDARD UTIL-STDN 401

1/25/12  
*Kevin Weyman* 2-6-12  
 CITY ENGINEER DATE  
*Chris J. Lott* 2/8/12  
 AURORA WATER DATE

INLET CONNECTION INTO  
 STORM SEWER MAIN

401

# STANDARD

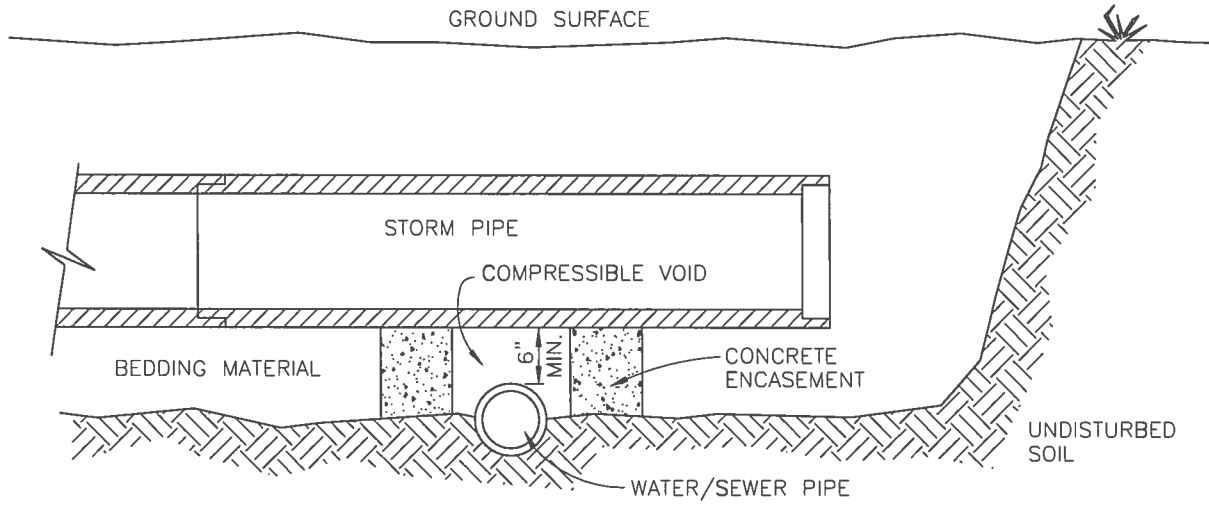

SECTION A-A  
NOT TO SCALE

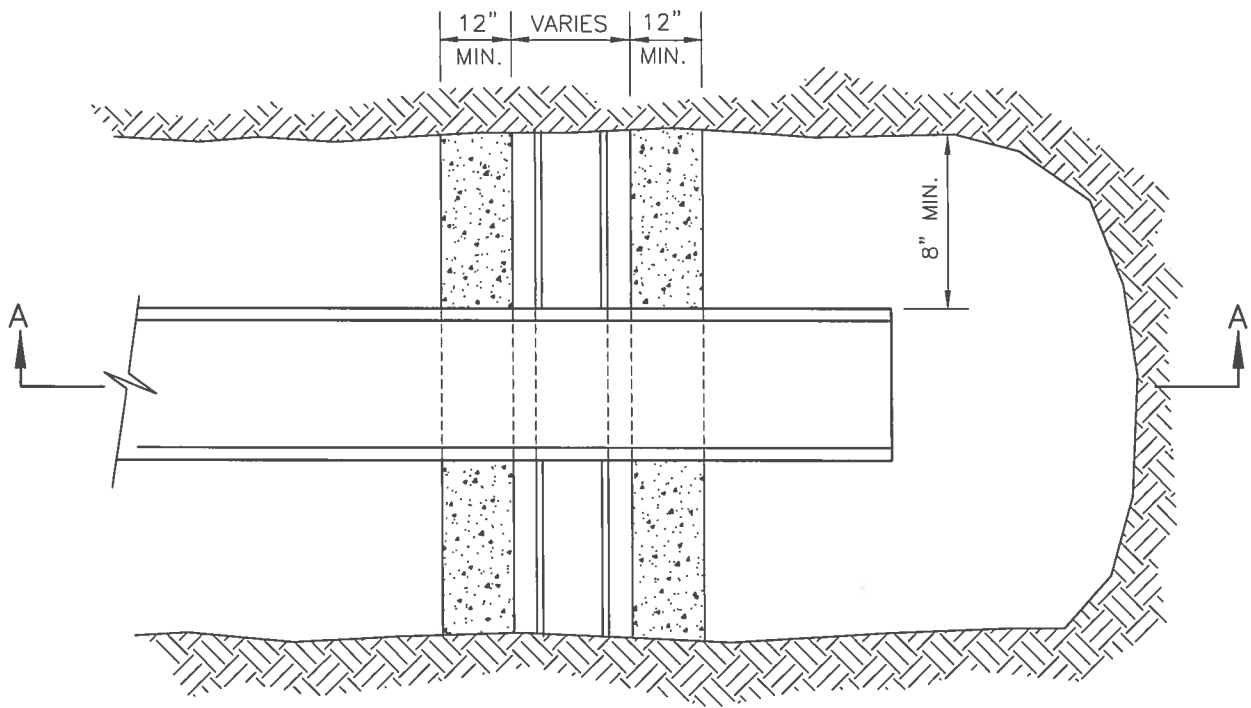

PLAN VIEW  
NOT TO SCALE

DRAFT STANDARDS \UTL-STD\402

*1/23/12*  
*Kevin Wegener* 2-6-12  
CITY ENGINEER DATE  
*Chris Zelt* 2/8/12  
AURORA WATER DATE

STORM SEWER DETAIL  
WATER OR SEWER  
CROSSING

402

# STANDARD

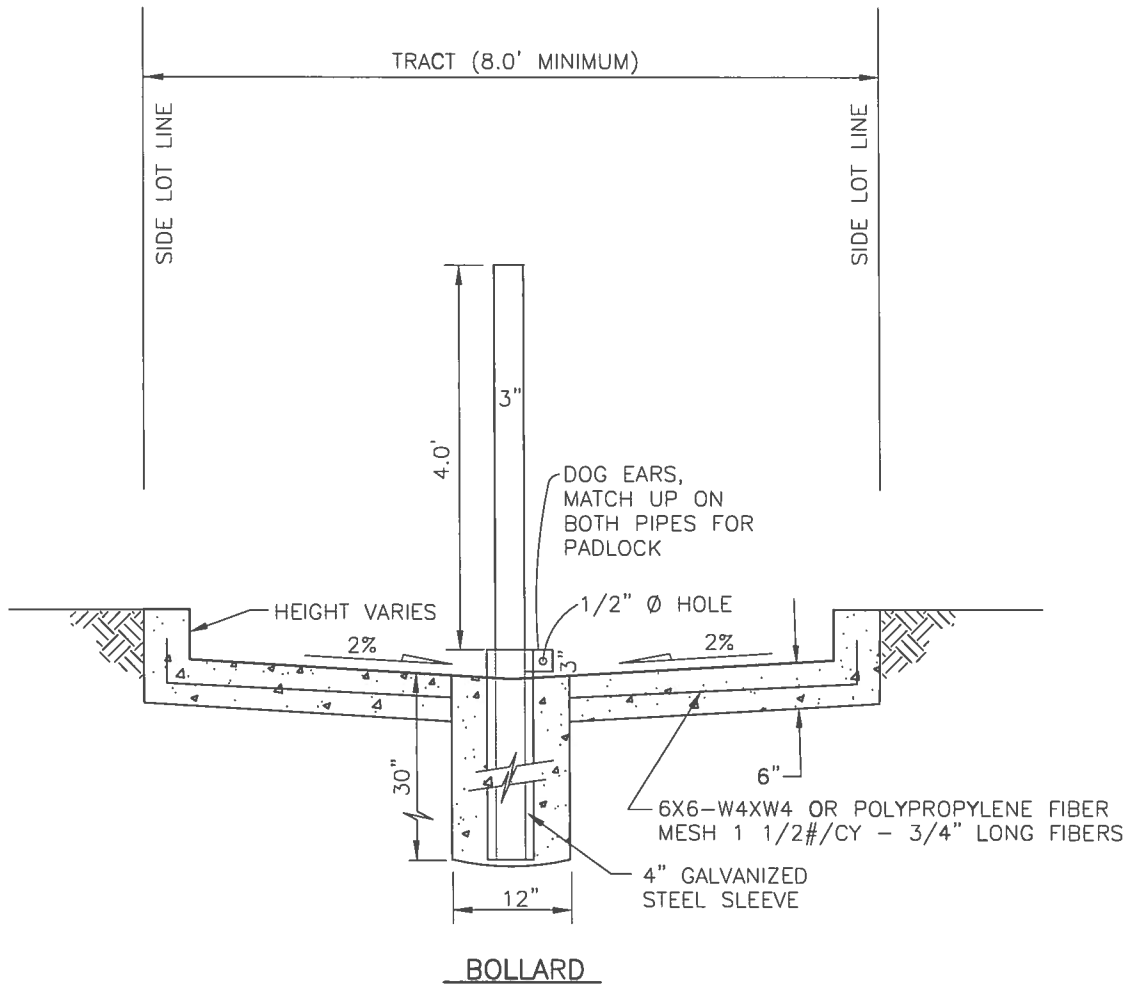

1. AT NO TIME SHALL THE DISTANCE BETWEEN BOLLARDS BE GREATER THAN 5'.
2. ALL BOLLARDS, EXCEPT FOR REMOVABLE POST, SHALL BE FILLED WITH CONCRETE.
3. ALL BOLLARDS SHALL BE GALVANIZED STEEL.
4. BOLLARDS ARE TO BE SET 5' TO 7' BACK OF SIDEWALK.
5. CHANNEL WIDTH = TRACT WIDTH (UNLESS OTHERWISE APPROVED.)

DRAFT STANDARDS UTIL - STD 403

*1/23/12*  
*Karin Wegener* 2-6-12  
 CITY ENGINEER DATE  
*Copy 2 PA* 2/6/12  
 AURORA WATER DATE

**TYPICAL CONCRETE  
DRAINAGE PAN**

**403**

STANDARD

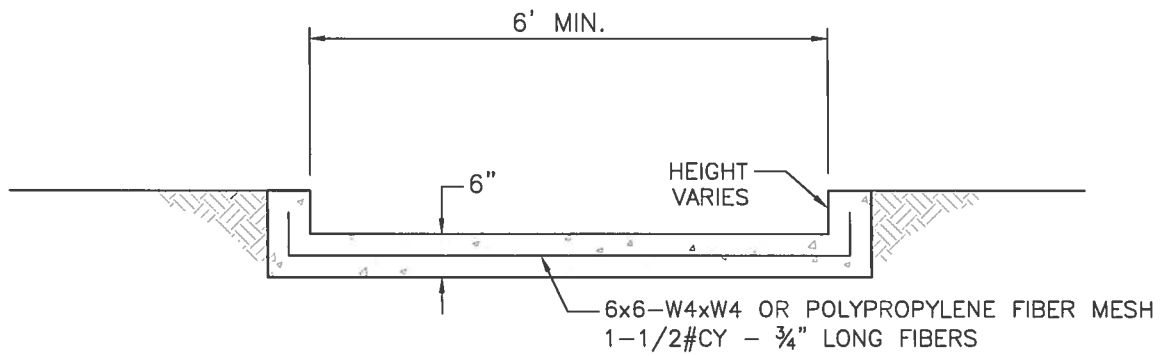

A) 0.4% MINIMUM LONGITUDINAL SLOPE

DRAFT STANDARDS \UTIL-STD\404

*1/23/12*  
*Kevin Wegner* 2-6-12  
CITY ENGINEER DATE  
*[Signature]* 2/8/12  
AURORA WATER DATE

LOW FLOW CHANNEL

404

**THIS PAGE IS INTENTIONALLY BLANK**



## APPENDIX B – APPROVED MATERIALS LIST

### 100 SERIES – GENERAL

<b>101 Manholes and Appurtenances</b>	<b>Page 4</b>
101.1 Precast Manhole Bases and Vaults	
101.2 Standard Rings and Covers	
101.3 Watertight Rings and Covers	
101.4 Lockable Manhole Lids	
101.5 Adjustable Slope Manhole Rings	
<b>102 Gaskets and Seals</b>	<b>Page 4</b>
102.1 Pipe Penetration Gaskets	
102.2 Preformed Plastic Gaskets	
<b>103 Linings and Coatings</b>	<b>Page 4</b>
103.1 Manhole Linings	
103.2 Rubberized Spray-on Undercoating	
<b>104 Grout</b>	<b>Page 5</b>
104.1 Premixed Nonmetallic, Non-shrink Grout	
104.2 Job Mixed Grout	
<b>105 Casing Spacers and Seals</b>	<b>Page 5</b>
105.1 Casing Spacers for Water Applications	
105.2 Casing Spacers for Wastewater Applications	
105.3 Casing seals	
<b>106 Miscellaneous</b>	<b>Page 5</b>
106.1 Foam Insulation	

## **200 SERIES – WATER SYSTEM**

<b>201 Pipe and Fittings</b>	<b>Page 6</b>
201.1 Class 250 Ductile Iron Pipe	
201.2 C900 and C905 PVC	
201.3 Lock Joint Pipe	
<b>202 Valves</b>	<b>Page 6</b>
202.1 Gate Valves	
202.2 Valve Boxes	
202.3 Butterfly Valves	
202.4 21 Inch Extended Operators	
202.5 Air Relief Valves	
202.6 Pressure Reducing Valves	
202.7 Check Valves	
<b>203 Joints</b>	<b>Page 7</b>
203.1 Joint Restraint Harnesses for Bell and Spigot PVC	
203.2 Joint Restraint Harnesses for MJ PVC	
203.3 Joint Restraint Harnesses for DIP	
203.4 Restrained Joints PVC	
203.5 Restrained Joints DIP	
203.6 Mechanical Joint for Steel Pipe	
<b>204 Water Services</b>	<b>Page 8</b>
204.1 Tapping Saddles	
204.2 Corporation Stops	
204.3 Curb Stops – ¾” and 1”	
204.4 Curb Stops – 1 1/2”	
204.5 Curb Stops – 2”	
204.6 Curb Stop Boxes – ¾” and 1”	
204.7 Curb Stop Boxes – 1 1/2” and 2”	
204.8 Service Line Couplings – Compression	
204.9 Meter Setters – ¾” and 1”	
204.10 Meter Setters – 1 1/2” and 2”	

**205 Corrosion Protection**

**Page 9**

- 205.1 Post Mounted Test Stations
- 205.2 Spray Primer
- 205.3 Weld Caps
- 205.4 Heat Shrink Sleeves
- 205.5 Steel Pipe Coatings
- 205.6 Polyethylene tubing
- 205.7 Polyvinyl Chloride Tape

**206 Other**

**Page 9**

- 206.1 Fire Hydrants
- 206.2 Foster Adapters
- 206.3 Swivel Adapters

**300 SERIES – SANITARY SEWER SYSTEM**

**301 Pipe**

**Page 11**

- 301.1 DIP
- 301.2 PVC

**PROCEDURE FOR PRODUCT APPROVAL**

## **100 SERIES – GENERAL**

### **101 MANHOLES AND APPURTENANCES**

#### **101.1 Precast Manhole Bases and Vaults**

- AMCOR

#### **101.2 Standard Rings and Covers**

- Neenah, R-1706 for built-up construction
- Neenah, R-1706 1S for slab construction

#### **101.3 Watertight Rings and Covers**

- Neenah, R-6461-GH for slab construction
- Neenah R-6464-F for built-up construction

#### **101.4 Lockable Manhole Lids**

- Neenah, R-1926-B with Type J-T Handle Bar Lock
- East Jordan 2045 with Type 5T Handle Bar Lock

#### **101.5 Adjustable Slope Manhole Rings**

- East Jordan Iron Works – PCSI

### **102 GASKETS AND SEALS**

#### **102.1 Pipe Penetration Gaskets**

- Kor-N-Seal
- Press Seal PS-10
- A-Lok
- Interpact Lock Joint

#### **102.2 Preformed Plastic Gasket**

- Mar Mac – MacWrap
- Rub-R-Nek
- Kent Seal, Butyl Rubber Sealant
- General Sealants GS #79, #44, or #4
- Conseal CS202

### **103 LININGS AND COATINGS**

#### **103.1 Manhole Linings**

- Fosroc Epoxy Liner HBS 100
- Raven 405
- Tnemec Elasto-Shield Series 262
- CIM 1000
- Sewer Shield 101

### **103.2 Rubberized Spray-on Undercoating.**

- NAPA
- Mac's Rubberized Undercoating
- Tite-Seal Rubberized Undercoating

## **104 GROUT**

### **104.1 Pre-mixed, Nonmetallic, Non-shrink Grout**

- Master Builders; "Embeco Mortar"
- Sonneborn; "Ferrolith G-D.S. Redi-Mixed"

### **104.2 Job-mixed grout**

- Master Builders; "Embeco Aggregate"
- Sonneborn; "Ferrolith G-D.S"

## **105 CASING SPACERS AND SEALS**

### **105.1 Casing Spacers for Water Applications**

- Uniflange Casing Spacers
- Raci Casing Spacers of North America
- Cascade, CCS
- PSI, Model S

### **105.2 Casing Spacers for Wastewater Applications**

- Raci Casing Spacers of North America
- Cascade, CCS
- PSI, Model S or the Adjusta-Spacer

### **105.3 Casing Seals**

- Cascade, CCES
- Canusa Seal Kit CSK
- PSI, model C, W

## **106 MISCELLANEOUS**

### **106.1 Foam Insulation**

- Dow Styrofoam - 100 high load insulation board
- Amoco - Amofam RCY
- Owens Corning - Formular 400 or 404

## **200 SERIES - WATER SYSTEM**

### **201 PIPE AND FITTINGS**

#### **201.1 Class 250 Ductile Iron**

- American
- Griffin
- Pacific States Cast Iron Pipe Company
- SIP Industries

#### **201.2 C900 and C905 P.V.C.**

- Certainteed
- Diamond
- J-M Manufacturing Company
- PW Eagle
- Uponor
- Vinyl Tech

#### **201.3 Lock Joint Pipe**

- American Ball Joint Pipe

### **202 VALVES**

#### **202.1 Gate Valves**

- AVK
- AFC 250 series
- Mueller A-2360 Series
- Metroseal 250 series
- Waterous
- Clow
- M & H

#### **202.2 Valve Boxes (Class 35)**

- Tyler series 6860 with a #6 base and drop lid
- Tyler series 6850 with drop lid
- East Jordan Iron Works 8550 and 8560 series with drop lid

#### **202.3 Butterfly Valves**

- Pratt – Groundhog
- Clow/M&H – Series 45000
- Mueller – Linesal III or XP

#### **202.4 21-inch Extended Operators**

- Limitorque
- MDT
- Valmatic
- EIM
- DeZurick

#### **202.5 Air Relief Valves**

- APC
- Valmatic

#### **202.6 Pressure Reduction Valves**

- Cla-Val 90G-01KC

#### **202.7 Check Valves**

- Cla-Val 81-G02KC

### **203 JOINTS**

#### **203.1 Joint Restraint Harnesses – for Bell and Spigot PVC**

- EBAA – Series 1500
- Star Pipe “PVC Grip” – Series 1100
- Uni-Flange – Series 1600

#### **203.2 Joint Restraint Harnesses– for MJ PVC**

- EBAA Series 15PF00TD
- Star Pipe “PVC Grip” - Series 3500
- Uni-Flange - Series 1500

#### **203.3 Joint Restraint Harnesses– for Ductile Iron**

- Uni-Flange – Series 1400
- Star Pipe “Star Grip” - Series 3000
- EBAA Iron Mega-lug Series 1100

#### **203.4 Restrained Joints – PVC**

- Megalug Restraining System
- Ford Uni-Flange Buster Series 1300 or 1500
- MJ Field-Loks 1390-C series

#### **203.5 Restrained Joints – DIP**

- CertainTeed - Certa-Lok
- Mechanical Joint
- MJ Field-Loks

#### **203.6 Mechanical Joints for Steel Pipes**

- Dresser Style 38

## **204 WATER SERVICES**

### **204.1 Tapping Saddles**

- Power Seal – 202B Series for DIP or PVC
- Mueller – BR2B Series

### **204.2 Corporation Stops**

- Mueller 300
- Ford B44
- A.Y. McDonald

### **204.3 Curb Stops – 3/4 " and 1"**

- Ford - B44
- A.Y. McDonald; 6100
- Mueller 300

### **204.4 Curb Stops - 1 1/2"**

- Ford; B22 - 666M
- Y. McDonald; 6104
- Mueller 300

### **204.5 Curb Stops - 2"**

- Ford; B22 - 777M
- Y. McDonald; 6104
- Mueller 300

### **204.6 Curb Stop Boxes - 3/4 " and 1"**

- Mueller H-10300
- Ford EM -50-56
- A.Y. McDonald 5614

### **204.7 Curb Stop Boxes - 1 1/2" and 2"**

- Mueller H-10304
- Ford EM2-50-57
- A.Y. McDonald 5615

### **204.8 Service Line Couplings (Compression Only – with Grip Tite rings)**

- Ford
- Mueller
- A.Y. McDonald

### **204.9 Meter Setters 3/4 " and 1" (with integral outlet spring check valve)**

- Ford
- A.Y. McDonald



#### **204.10 Meter Setters - 1 1/2" and 2"**

- Ford
- A.Y. McDonald
- Mueller

### **205 CORROSION PROTECTION**

#### **205.1 Post Mounted Test Stations**

- Testox 700 Series (1 1/4" Threaded), Gerome Manufacturing Company

#### **205.2 Spray Primer**

- Royston Roybond 747

#### **205.3 Weld Caps**

- Royston Handy Cap
- Tapecoat H35 Gray
- Canusa melt stick
- Canusa CRP Patch

#### **205.4 Heat Shrink Sleeves**

- Canusa

#### **205.5 Steel Pipe Coatings**

- Protec II – Futura Coatings
- Durashield 210 – Lifelast, Inc.

#### **205.6 Polyethylene Tubing**

- Manufactured from Dupont Alathon Resin

#### **205.7 Polyvinyl Chloride Tape**

- Polyken #900
- Scotchwrap #50

### **206 OTHER**

#### **206.1 Fire Hydrants (Safety Yellow per AWWA C502)**

- Mueller, Super Centurion
- Waterous Pacer, WB67-250
- Clow Medallion, 2546-5B
- AVK

#### **206.2 Foster Adapter**

- INFACT Corp

### **206.3 Swivel Adapters**

- Tyler
- Sigma
- Romac

## **300 SERIES – SANITARY SEWER**

### **301 PIPE**

#### **301.1 Ductile Iron**

- Griffin Pipe H<sub>2</sub>SewerSafe
- U.S. Pipe with Polybond Lining
- American Ductile Iron Polybond lined pipe, or Polybond Plus lining

#### **301.2 PVC**

- IPEX
- J-M Manufacturing Company

## PROCEDURE FOR PRODUCT APPROVAL

1. Contractors, suppliers and manufacturers desiring to submit products for approval and inclusion in these Standards shall submit materials detailed below to the Aurora Water Warehouse at 13645 E. Ellsworth Ave., Aurora CO. 80012. Contractors, suppliers and manufactures wishing to visit warehouse supervisor in person shall first request an appointment by calling (303) 326-8500.
2. The City will complete its review within 90 days. Contractors, suppliers and manufacturers desiring to appeal the decision of the review committee shall submit an appeal to the Manager of Aurora Water Engineering within 30 days after the final decision by the review committee.
3. Aurora Water shall review the appeal and render a decision within 30 days. The decision of the Director will be final.
4. Contractors, suppliers and manufacturers desiring to submit materials for approval and inclusion in these Standards shall submit the following minimum information:
  - a Manufacturer's standard drawings, schematics and diagrams:
    - i Description of the material or equipment for which the supplier or manufacturer desires to be considered.
    - ii Delete information not applicable to the submittal.
    - iii Supplement standard information to provide information specifically applicable to the material or equipment.
    - iv Detailed operation and maintenance and disassembly information for maintenance if applicable.
    - v Applicable standards, such as ASTM or Federal Specification numbers.
    - vi Manufacturer's name, type and model number of equipment.
    - vii Drawings, catalogs or parts thereof, manufacturer's specifications and data, instructions, performance characteristics and capacities, and other information specified or necessary.
    - viii Parts, devices, controls and accessories forming a part of equipment.
    - ix Descriptive literature for paint and coating systems.
    - x Description of where parts may be ordered and anticipated time for delivery of parts.

- b Manufacturer's warranties.
- c Format.
  - i Present in a clear and thorough manner.
  - ii Minimum sheet size: 8 1/2"x11".
  - iii Clearly mark each copy to identify pertinent products and models.
  - iv Individually annotate standard drawings which are furnished, cross out items that do not apply, describe exactly which parts of the drawing apply to the equipment being considered.
  - v Individually annotate catalog sheets to identify applicable items.
  - vi Clearly identify the Supplier and Manufacturer along with addresses, telephone number and person to contact for additional information.

**THIS PAGE IS INTENTIONALLY BLANK**

## **Appendix C**

### **Rules and Regulations Regarding Wastewater Control**

## Table of Contents

I.	General Information and Definitions .....	4
A.	Authority .....	4
B.	Effective Date .....	4
C.	Purpose.....	4
D.	Amendments .....	4
E.	Severability .....	4
F.	Definitions .....	4
II.	General Requirements .....	7
A.	Authority .....	7
B.	Commercial and Industrial Discharge Permits.....	7
1.	Commercial Wastewater Discharge Permit.....	7
2.	Industrial Wastewater Discharge permits:.....	8
3.	Duration and Reissuance .....	8
4.	Transferability .....	8
5.	Violation .....	8
C.	Review of Plans .....	8
D.	City Notifications .....	9
E.	Discharge Limitations on Wastewater .....	9
F.	Storm Sewer and Storm Drainage System Connections .....	10
G.	Abandonment of Wastewater Pre-treatment Devices .....	10
H.	Notification of Violations .....	10
III.	Grease Interceptors.....	11
A.	Applicability .....	11
B.	Materials and Structures.....	11
C.	Sizing.....	12
Method 1: 2006 UPC Formula.....		12
Method 2: Drainage Fixture Unit Calculation .....		13
Method 3: for Schools (Public and Private) .....		13
D.	Maintenance and Inspections.....	14
E.	Kitchen Best Management Practices (BMP) .....	14
1.	BMPs for Food Preparation Establishments .....	14
2.	Additional BMPs for Kitchens with food waste grinders .....	15
IV.	In-Line Grease Traps.....	15
A.	Applicability .....	15
B.	Sizing.....	15
C.	Materials and Structures.....	15
D.	Maintenance and Inspections.....	16
V.	Flow Equalization Units.....	16



- A. Applicability ..... 16
- B. Materials and Structures ..... 17
  - 1. Tank ..... 17
  - 2. Bypass ..... 17
  - 3. Pump ..... 17
  - 4. Timer and Seal ..... 17
- C. Maintenance and Inspections ..... 18
- VI. Acid Neutralization ..... 18
  - A. Applicability ..... 18
  - B. Materials and Structures ..... 18
    - 1. Neutralization Media ..... 18
    - 2. Other Chemical Wastewater Pre-treatment Methods ..... 18
  - C. Sizing ..... 19
  - D. Maintenance and Inspections ..... 19
- VII. Sand and Oil Interceptors ..... 19
  - A. Materials and Structures ..... 20
  - B. Location ..... 20
  - C. Sizing ..... 20
    - 1. Trough Drains ..... 20
    - 2. Vehicle Wash Drains ..... 20
  - D. Maintenance and Inspections ..... 21
- VIII. Trailer Courts and Mobile Home Parks ..... 21
- IX. Elevator Pits ..... 22
- X. Venting ..... 23
  - A. Vents not required ..... 23
  - B. Materials ..... 23
  - C. Size of Vents ..... 23
  - D. Vent Pipe Grades and Connections ..... 24
  - E. Vent Termination ..... 24
- XI. Swimming Pools ..... 25
  - A. Discharge to the Sanitary Sewer ..... 25
  - B. Discharge to the Storm Sewer ..... 26
- XII Metro Discharge Limitations ..... 27
- XIII City of Aurora Discharge Limitations ..... 32

# RULES AND REGULATIONS GOVERNING WASTEWATER CONTROL

---

## I. General Information and Definitions

### A. Authority

These Rules and Regulations are issued by the Director of Aurora Water and the City of Aurora, Colorado in accordance with, and are supplemental to Chapter 138 Article VI of the City of Aurora Municipal Code.

### B. Effective Date

The Wastewater Rules and Regulations are effective on and after January 1, 2012 and supersede all former Rules and Regulations governing wastewater control.

Amendments

### C. Purpose

These rules and regulations set forth uniform requirements for direct and indirect contributors to the wastewater collection and treatment system of the City and enables the City to comply with all requirements of the Metro Wastewater Reclamation District, applicable state laws and the general pre-treatment regulations issued pursuant to the Clean Water Act of 1977.

### D. Amendments

These Rules and Regulations may be altered from time to time, and such alterations, changes, additions, or amendments shall be binding, and in full force effective as of the date of the filing and publication.

### E. Severability

In the event any provision of these Rules and Regulations or circumstances is held invalid, such invalidity shall not affect any other provision or application.

### F. Definitions

In addition to the definitions set forth in Chapter 138, Article VI, of the City of Aurora Municipal Code entitled "Wastewater Control" and as used in these Rules and Regulations; unless the context clearly indicates otherwise, the present words and expressions shall be defined as follows:

**Acid Neutralization Unit** - a vessel made in various sizes and filled to a specified level with an approved acid-neutralizing agent through which acidic liquid wastes can be passed for acid neutralization.

**Best Management Practices or BMPs** - schedules of activities, prohibitions of practices, maintenance procedures, and other management practices to reduce pollutants.

**Commercial User** - any non-domestic source discharging Pollutants into a Publicly Owned Treatment Works (POTW). Industrial Users fall under the commercial use category.

**Drainage Fixture Unit** - a rating in terms of gallons per minute (GPM) representing the maximum amount of water which can drain from a fixture or piece of equipment in one minute. The value of one drainage fixture unit (DFU) is equal to 7.5 GPM.

**Flow Equalization Unit** - a structure or structures with equipment or attachments for the purpose of delaying, detaining, equalizing or otherwise controlling the flow or discharge of wastewater from a premise through a building sewer into a public sewer.

**FOG** - Fats, oils and grease

**Food Preparation Establishment** - a commercial business or institution where food is prepared and intended for individual portion service and includes the site at which the individual portions are provided, whether consumption occurs on or off the premises. Additionally includes all food manufacturing and packaging facilities.

**Grease Interceptor** - typically a two compartment pre-cast concrete tank, interceptors are normally located outside of the building. The second compartment shall have 1/3 total capacity of the tank.

**“In line” Grease Trap** - a prefabricated unit for trapping of fats, oil, grease and food solids. Typically installed inside of the building, flush with the finish grade and located outside of the food prep area.

**Metro, District or Metro District** - means the Metro Wastewater Reclamation District located at 6450 York Street, Denver, Colorado 80229. Wherever approval of or correspondence with the District is referred to, it shall mean the District Manager of the District unless otherwise specified.

**POTW or Publicly Owned Treatment Works** - means a treatment works which is owned in this by the Metro District or Aurora Water. This definition includes any devices or systems used in the collection, storage, treatment, recycling, and reclamation of sewage and any sewers conveying wastewater to the Metro District or Aurora Water treatment plant. For the purposes of these Rules and Regulations, POTW shall also include any sewers conveying wastewaters to the POTW from persons outside the District or the City of Aurora who are users of the District or Aurora Water POTW.

**POTW Treatment Plant** - means the portion of the POTW designed to provide treatment to wastewater.

**Pre-treatment Device** - means an apparatus or method used to treat or remove pollutants from the wastewater stream such as grease interceptors, sand/oil interceptors, acid neutralization tanks, flow equalization units, etc.

**Pre-treatment Requirement or Requirement** - means any substantive or procedural requirement related to pre-treatment, other than a Pre-treatment Standard imposed on an Industrial User directly permitted by the Metro District.

**Private Sanitary Sewer Service Line** - the building sewer from the foundation to the publically maintained sewer main, including the tapping saddle or tee on the main.

**Production Units** - Units of measurement of a product or industry.

**Sampling** - A periodic collection of wastewater as it flows through a public or private sewer conveyance system.

**Sand and Oil Interceptors** – typically a two compartment pre-cast concrete tank, interceptors are normally located outside of the building. The second compartment shall have 1/3 total capacity of the tank.

**Significant Industrial User** - Significant Industrial User means:

- (a) any Commercial/Industrial User subject to Categorical Pre-treatment Standards under 40 CFR §403.6 and 40 CFR Chapter I, Subchapter N;
- (b) any Commercial/Industrial User designated as such by the Metro District on the basis that the Commercial/Industrial User has a reasonable potential for adversely affecting District operations or for violating any Pre-treatment Standard or Requirement;
- (c) any Commercial/Industrial User discharging an average of 25,000 gallons per day or more of process wastewater to the sanitary sewer system (excluding sanitary, non-contact cooling, and boiler blowdown wastewater); and
- (d) any Commercial/Industrial User discharging a process waste stream which makes up five percent (5%) or more of the average dry weather hydraulic or organic capacity of the Metro District's treatment plant.

Upon a finding a Commercial/Industrial User meeting the criteria in paragraph (a) above never discharges more than 100 gallons per day (gpd) of total categorical wastewater (excluding sanitary, non-contact cooling and boiler blowdown wastewater, unless specifically included in the Pre-treatment Standards) the Metro District may determine the Commercial/Industrial User a Non-significant Categorical Commercial/Industrial User if the following conditions are met:

1. the Commercial/Industrial User, prior to the Metro District's finding, has consistently complied with all applicable categorical pre-treatment standards and requirements;

2. the Commercial/Industrial User annually submits the certification statement required in 403.12(q) together with any additional information necessary to support the certification statement; and
3. the Commercial/Industrial User never discharges any untreated concentrated wastewater. Upon a finding a Commercial/Industrial User meeting the criteria in paragraphs (b), (c), or (d) above has no reasonable potential for adversely affecting the Metro District's operation or for violating any Pre-treatment Standard or Requirement, the District may at any time, on its own initiative or in response to a petition received from a Municipality or Commercial/Industrial User, determine such Commercial/Industrial User is not a Significant Industrial User.

**Testing** - The analysis of wastewater.

**Wastewater Control Ordinance** - Operating regulations for the control of the use of the Aurora Municipal Wastewater Collection System, Treatment System, and Storm Drainage System known as Chapter 138, Article VI of the City of Aurora Municipal Code.

**Wastewater Pre-treatment Facilities** - Structures, devices or equipment, such as Grease and Sand/Oil Interceptors or Flow Equalization Units for the purpose of neutralizing or removing deleterious wastes from wastewater generated from a premise prior to its discharge into a public sewer.

## **II. General Requirements**

### **A. Authority**

Notwithstanding the issue of any permit, the City of Aurora reserves the full power and authority to determine all matters in connection with the control and use of its Wastewater Collection and Treatment Systems. Furthermore the Director shall have the authority to suspend, modify or revoke, with cause any such permit in accordance with Chapter 138 of the City of Aurora Municipal Code.

### **B. Commercial and Industrial Discharge Permits**

#### **1. Commercial Wastewater Discharge Permit**

All commercial and industrial users contributing to or proposing to connect to, or change the nature or amount of discharge to the POTW shall provide to the City a Commercial Wastewater Discharge Permit Applications and Questionnaire before connecting to or discharging o the POTW.

## **2. Industrial Wastewater Discharge permits:**

Significant Industrial Users are required to obtain an Industrial Wastewater Discharge Permit with Metro in accordance with Article VI, Division 1, Chapter 138-291 of the City of Aurora Code.

## **3. Duration and Reissuance**

Commercial wastewater discharge permits may be issued for a specified term or an indeterminate period of time. Industrial wastewater discharge permits shall be issued for a specified term not to exceed five years, and may be issued for a period less than a year or may be stated to expire on a specific date. Each user shall apply for permit reissuance at least 180 days prior to the expiration of the user's current commercial or industrial wastewater discharge permit.

## **4. Transferability**

Wastewater discharge permits are issued to a specific user for a specific operation. A wastewater discharge permit shall not be reassigned or transferred or sold to a new owner, new user, different premises, or a new or changed operation without prior notification to and approval by the appropriate issuing authority. A copy of the existing permit must be provided to the prospective transferee prior to such transfer.

## **5. Violation**

It shall be unlawful for any user to violate or fail to comply with any condition of a wastewater discharge permit.

(Code 1979, § 39-105(a); Ord. No. 2000-26, § 1, 4-24-2000; Ord. No. 2005-74, § 1, 10-10-2005)

## **C. Review of Plans**

Location of pre-treatment facilities is reviewed with the Site Plan submittal to the Planning Department, and the Civil Plan submittal. Sizing of pre-treatment facilities is reviewed with the Building Plan submittal. If either of these submittals is not required, it is the responsibility of the generator and his/her contractor to contact Aurora Water Engineering for approval of the facility.

Aurora Water Engineering may request additional plans and information which may be needed to determine the impact on the wastewater collection system of the proposed waste(s) and the size of the wastewater pre-treatment facilities which may be required.

In the event it becomes necessary for the Director of Aurora Water to require an existing business or industrial user to install suitable wastewater pre-treatment and/or flow equalization units, a written explanation for the requirement shall be furnished to the owner or the authorized agent thereof. Such a requirement may arise when it becomes apparent waste discharged from the business or industry is in violation of the City Code and/or may cause harm to the public sewer system, persons entering the sewer system to perform maintenance, the treatment process, the POTW, and/or the environment. The request shall be based on one of the following determinations:

- a) **Direct sampling.** Direct sampling shall be used wherever possible. A sample taken at a control structure shall be analyzed as prescribed by Chapter 138 of the Wastewater Control Ordinance.
- b) **Comparisons.** When direct sampling is not possible, comparison with another similar process, the composition and/or volume of the wastewater being known to be of a similar nature to of the business or industry in question, shall be used.

**Best Judgment.** Best judgment shall be made where it is not possible to sample and where a similar process to which a comparison does not exist. Best judgment shall be based on reasonable knowledge of the processes involved, the nature of the wastewaters produced by such processes and the amount of water consumption.

## **D. City Notifications**

The owners of any establishment requiring a wastewater pre-treatment facility shall notify Aurora Water Engineering as follows:

- A. Prior to the construction of a new business or facility requiring a wastewater pre-treatment device
- B. Upon change or transfer in ownership of a business requiring a wastewater pre-treatment device
- C. Upon a significant change in process and operations, including change in the menu of a food establishment resulting in a substantial increase the use and discharge to the wastewater collection system of fats, oil and grease, which otherwise changes the quantity, quality and/or content of wastewater discharges.
- D. Upon any change in the type or size of such facility which would dictate a deviation from the plumbing plans.
- E. Upon installation of the new wastewater pre-treatment facility prior to the water test of the plumbing system for onsite review and approval of the facility.
- F. Upon the decommissioning or abandonment of an existing pre-treatment device.

## **E. Discharge Limitations on Wastewater**

Wastewater shall not contain or exhibit the characteristics as set forth in Section 6 of the Metro Wastewater Reclamation District Rules and Regulations or as set forth in Article VI, Division 1, Chapter 138-263 of the City of Aurora Code. In the event where multiple

discharge limitations exist for the same contaminant, the most stringent limitation shall apply.

Notwithstanding the provisions of this Section, the Director of Aurora Water may, on a case by case basis, require more stringent limitations in a wastewater discharge permit, issued to a particular user, to prevent interruptions of service, increased maintenance for the City, or any other interference with the operation of the system.

## **F. Storm Sewer and Storm Drainage System Connections**

No direct physical connection from any storm drainage pipe or system shall be allowed into the wastewater collection system.

## **G. Abandonment of Wastewater Pre-treatment Devices**

1. In the event the use of a building changes where no wastewater pre-treatment of wastes is needed or required, the abandoned devices shall be pumped and cleaned of accumulated material and:

Disconnected from service; removed from the ground and hauled away for proper disposal or:

Disconnected from service, filled with sand or other approved material and bypassed.

2. As an abandoned wastewater pre-treatment device may constitute a danger to those in the area and/or the public sewer system, improper abandonment shall be considered a violation of Chapter 138 of Aurora Municipal Code and will be grounds for issuance of a Notice of Violation or Summons and Complaint by Aurora Water.

3. Proper abandonment shall be considered the responsibility of the present owner(s) or tenant(s).

4. All wastewater pre-treatment unit abandonment activities must be approved and inspected by Aurora Water Engineering Division.

## **H. Notification of Violations**

1. Failure to maintain any wastewater pre-treatment facility in efficient working condition shall constitute a violation of the Wastewater Control Ordinance Chapter 138.

2. Any unauthorized alteration or damage to any wastewater pre-treatment facility or method shall constitute a violation of the Wastewater Control Ordinance Chapter 138.

3. When a violation to the Wastewater Control Ordinance, these Rules and Regulations, Wastewater Discharge Permit or any applicable Code or Rules and Regulations is determined to exist, the Director of Aurora Water or his/her authorized agent shall issue to the responsible person a notice of violation. This notice shall contain at least the following:



- A. The name of the person cited for the violation.
- B. Location of the violation.
- C. Details of the violation.
- D. Corrective action to be taken by the cited person.
- E. Time limit for the corrective action to be taken.
- F. Penalty for non-compliance.
- G. Statement on alternative immediate action available to the City in accordance with Chapter 138 of the Wastewater Control Ordinance.

4. Should the violation still exist after the time limit on the notice to comply has elapsed, the Director of Aurora Water or the authorized representative may invoke legal actions as provided for in Wastewater Control ordinance Chapter 138.

### **III. Typical Grease Interceptors**

All interceptors shall be installed in accordance with Detail #303, Appendix A; Standards and Specifications Regarding Water, Sanitary Sewer and Storm Drainage Infrastructure, latest revision.

#### **A. Applicability**

1. Grease Interceptors shall be required for all food preparation establishments (cafes, fast food outlets, pizza outlets, delicatessens, sandwich shops, coffee shops), animal slaughter houses, soap factories, tallow/fat rendering establishments, hide curing establishments, schools, nursing homes; and others establishments capable of discharging fats, oil and grease into the City of Aurora Sanitary Sewer Collection System.

2. Grease interceptors required by these rules and regulations shall be installed unless the city determines the installation of a grease interceptor would not be feasible due to space constraints. The facility bears the burden of demonstrating the installation of a grease interceptor is not feasible and the variance will not lead to violations of these rules and regulations. Any food preparation establishment granted a variance from a grease interceptor requirement shall implement best management practices per these rules and regulations such that an equivalent level of treatment is achieved.

3. Grease interceptors will not be required for private residences or dwellings.

#### **B. Materials and Structures**

1. All interceptors shall be located outside, on private property whenever possible within thirty (30) feet of the facility served. The location of a food establishment above the first floor of its respective building shall not be considered sufficient reason to eliminate the requirement for a grease interceptor.

2. All interceptors shall be pre-cast concrete and have two compartments, the smallest which shall have at least 1/3 the capacity of the entire interceptor.

### C. Sizing

It is the responsibility of the generator and his/her contractors and consultants to ensure the wastewater discharge from their facility is in compliance with the City's discharge limitations. For the purpose of plan review, a general assessment of grease interceptor design will be performed using the following formulas:

#### Method 1: 2006 UPC Formula

Meals per Peak Hour	Waste Flow Rate	Retention Time	Storage Factor	Capacity (gal)	Interceptor Size (gal)
(1)	(2)	(3)	(4)	(5)	

(1) X (2) X (3) X (4) = (5) →

#### Step 1 – Meals per Peak Hour = Seating Capacity X Meal Factor

##### Meal Factors

Fast Food (45 min).....	1.33
Restaurant (60 min).....	1.00
Leisure Dining (90 min).....	0.67
Dinner Club (120 min).....	0.50

#### Step 2 – Waste Flow Rate:

With Dishwasher.....	6 gallon flow
Without Dishwasher.....	5 gallon flow
Single Service Kitchen.....	2 gallon flow
Food Waste Disposer.....	1 gallon flow

#### Step 3 – Retention Time

Commercial kitchen waste/dishwasher.....	2.5 hours
Single service kitchen.....	1.5 hours

#### Step 4 – Storage Factor

Commercial kitchen – 8 hour operation.....	1
Commercial kitchen – 16 hour operation.....	2
Commercial kitchen – 24 hour operation.....	3
Single service kitchen.....	1.5

#### Step 5 – Capacity

Multiply values from Steps 1-4. The result is the minimum approximate grease interceptor size for this application.

**Method 2: Drainage Fixture Unit Calculation**

Where food is prepared, but as a general rule not consumed on the premises, or where seating capacity or number of meals served cannot adequately be determined, the following rule shall apply:

The following table establishes the drainage fixture unit values for various pieces of kitchen equipment, which may require connection to a grease interceptor. One drainage fixture unit shall equal 7.5 GPM. The total number of drainage fixture units shall be multiplied by 7.5 GPM to determine maximum rate of flow (GPM) possible into the grease interceptor. The volumetric capacity of the unit shall be five times the maximum rate of flow.

**Fixture Unit Values**

Type of Fixture	Fixture Unit Value
Clothes Washer.....	3
Combination Sink and Tray with Food Waste Grinder.....	4
Combination Sink and Tray with one 1 ½ Inch Trap .....	2
Combination Sink and Tray with Separate 1 ½ Inch Traps.....	3
Pot or Scullery Sink.....	4
Prep Sink.....	2
Service Sink (Standard Trap).....	3
Service Sink (P Trap).....	2
All Other Fixtures:	
1 ¼ Inch or less Trap Size.....	1
1 ½ Inch Trap Size.....	2
2 Inch Trap Size.....	3
2 ½ Inch Trap Size.....	4
3 Inch Trap Size.....	5
4 Inch Trap Size.....	6

Example: A total of 21 fixture units are to be discharged to a grease interceptor. 21 F.U. x 7.5GPM x 5 minute retention = 787.5 gallons.

**Method 3: for Schools (Public and Private)**

The sizing of grease interceptors for school kitchens shall be as follows:

Number of students x .6 (average daily participation) x 2.5 gallons per meal served equals volumetric capacity of grease interceptor. Example: 650 students x .6 ADP = 390 meals. 390 meals x 2.5 gallons/meal = 975 gallons.

School wastewater pre-treatment units shall be in accordance with the City of Aurora Standards.

## **D. Maintenance and Inspections**

1. Periodic operations and maintenance inspections are performed by Aurora Water to ensure compliance with the Wastewater Control Ordinance, these Rules and Regulations, and Wastewater Discharge Permits. It shall be the responsibility of those engaged in the operation of a business (commercial or industrial) activity to maintain their associated wastewater pre-treatment facilities in efficient functioning order.
2. Grease Interceptors shall be pumped and cleaned of their accumulated matter quarterly or as often as necessary to ensure maximum efficiency and to prevent non-compliance with applicable discharge limitations.
3. A grease interceptor is deemed to require service when settled solids and FOG exceed 25% of the liquid capacity of either compartment of the tank.
4. Aurora Water may require a business to maintain a specific grease interceptor pumping and cleaning interval based on observed problems or non-compliance related to grease production, accumulation and wastewater discharges.
5. Grease interceptor pumping, cleaning and hauling service companies hired to perform work for food preparation establishments in the City of Aurora must be properly accredited and licensed according to Colorado state law.
6. Maintenance and pumping records must be kept onsite for a minimum of three (3) years. Aurora Water reserves the right to require a business to routinely submit maintenance and pumping records to the City.
7. Partial cleaning of grease interceptors is not allowed.
8. Biological, enzymatic, chemical treatments of wastewater flows are not allowed.
9. Access to wastewater pre-treatment facilities shall remain unobstructed at all times. The removal of large objects such as boxes, crates, cans, etc. or the need for a ladder to inspect a wastewater pre-treatment facility shall constitute a violation of Wastewater Control Ordinance Section 138-292 (d)

## **E. Kitchen Best Management Practices (BMP)**

Kitchen BMPs benefit food preparation establishments by preventing grease discharges and keeping interceptor maintenance costs low.

### **1. BMPs for Food Preparation Establishments**

All food preparation establishments are required to follow kitchen best management practices (BMP), including, but not limited to the following:

- A. Regularly train all employees on fats, oil and grease control and management
- B. Prevent grease from entering drainage fixture units
- C. Excess food waste and grease must be scraped off plates prior to washing
- D. Food waste must be disposed of in the garbage
- E. Drain screens must be installed on all drainage fixture units
- F. Cooking grease (yellow grease) must be collected and recycled

**2. Additional BMPs for Kitchens with food waste grinders**

- Drains associated with food waste grinders must be plumbed to the Grease Interceptor. A solids interceptor shall separate the discharge upstream of the grease interceptor where food waste grinders are installed.

**IV. In-Line Grease Traps**

All grease traps shall be installed in accordance with the manufacturer’s and City specifications.

**A. Applicability**

In-line grease traps shall be allowed by the Aurora Water Department only where it is determined by the Department to be impractical to install a larger grease interceptor. Installation of in-line grease traps in lieu of grease interceptors requires written approval by Aurora Water Department.

**B. Sizing**

Grease traps shall have the grease retention capacity indicated below:

Total Flow Through Rating (gpm)	Grease Retention Capacity (pounds)
1-20	40
25	50
35	70
50	100

**C. Materials and Structures**

- 1. Each in-line grease trap shall be constructed of durable materials satisfactory with the Aurora Water Department, and shall have a full gas-tight cover, which can be easily and readily removed.
- 2. Water-jacketed grease traps shall not be approved or installed.
- 3. Each in-line grease trap shall have an approved water seal of not less than two (2) inches in depth or the diameter of its outlet, whichever is greater.

## **D. Maintenance and Inspections**

1. Periodic operations and maintenance inspections shall be performed by Aurora Water to ensure compliance with the Wastewater Control Ordinance, these Rules and Regulations, and Wastewater Discharge Permits. It shall be the responsibility of those engaged in the operation of a business (commercial or industrial) activity to maintain their associated wastewater pre-treatment facilities in efficient functioning order.
2. In-line grease traps shall be cleaned of their accumulated matter as often as necessary to ensure maximum efficiency and to prevent non-compliance with applicable discharge limitations.
3. An in-line grease trap is shall require service when settled solids and FOG exceed 25% of the liquid capacity of the tank.
4. Aurora Water may require a business to maintain a specific in-line grease trap cleaning interval based on observed problems or non-compliance related to grease production, accumulation and wastewater discharges.
5. Maintenance records must be kept onsite for a minimum of three (3) years. Aurora Water reserves the right to require a business to routinely submit maintenance records to the City.
6. Grease trap cleaning and hauling service companies hired to perform work for food service establishments in the City of Aurora must be properly accredited and licensed according to Colorado state law.
7. Partial cleaning of in-line grease traps is not allowed.
8. Biological, enzymatic, chemical treatments of wastewater flows are not allowed.
9. Access to wastewater pre-treatment facilities shall remain unobstructed at all times. The removal of large objects such as boxes, crates, cans, etc. or the need for a ladder to inspect a wastewater pre-treatment facility shall constitute a violation of Wastewater Control Ordinance Section 138-292 (d).

## **V. Flow Equalization Units**

All flow equalizer units shall be installed in accordance with the standard drawings of the City of Aurora.

### **A. Applicability**

1. These rules and regulations shall apply to all types of car or truck washing facilities, and other users of the collection system capable of discharging large volumes of wastewater. Plans for these facilities and operation shall be submitted to the Aurora Water Department for approval of the type and size of the wastewater pre-treatment facility which may be required and to determine the need for a wastewater holding tank.
2. Businesses washing five (5) cars or less per day shall not be required to install wastewater holding tanks. They shall, however, be required to install an approved sand/oil interceptor.

## **B. Materials and Structures**

### **1. Tank**

The need for a storage tank (holding tank) shall be based on actual or anticipated flows in the wastewater collection system at the point of connection and downstream so as to avoid sewer line surcharge. In the event such a tank is required, it shall have the following characteristics:

The storage tank shall have the capacity to hold one day's (24 hours) output of wastewater. It shall be the responsibility of the owner to ensure the adequacy of the storage tank.

### **2. Bypass**

Under no circumstances shall by-pass connection be installed between the washing operation and the sanitary sewer.

### **3. Pump**

A submersible sump pump with the capacity to drain the storage tank during a 5 to 6 hour period and, approved by the building division shall be installed. The maximum flow of the pump shall not exceed 225 GPM.

The submersible pump shall be controlled by a timing device which shall allow the pump to operate during the period of midnight to 6 am. Consequently, no more than 81,000 gallons of wastewater may be discharged during this 6 hour period. Manual controls shall not be allowed and the control panel shall be locked at all times. The City reserves the right to place a lead seal on the timer box door.

### **4. Timer and Seal**

Any time a seal must be broken in order to perform emergency repairs on the timer, and after the repairs have been completed, the seal shall be replaced by Aurora Water Department.

It shall be unlawful to remove a seal on the timer control box in order to change the hour at which the pump is to operate. Penalties shall be in accordance with Section 138 of the City Code.

## C. Maintenance and Inspections

1. Periodic operations and maintenance inspections shall be performed by Aurora Water to ensure compliance with the Wastewater Control Ordinance, these Rules and Regulations, and Wastewater Discharge Permits. It shall be the responsibility of those engaged in the operation of a business (commercial or industrial) activity to maintain their associated wastewater pre-treatment facilities in efficient functioning order.
2. All flow equalization devices (holding tanks) and other wastewater pre-treatment facilities not specifically mentioned here must be inspected annually (1 year) by their respective owners. Maintenance and inspection records must be retained on site for a minimum of three (3) years.
3. Partial cleaning is not allowed.
4. Access to wastewater pre-treatment facilities shall remain unobstructed at all times. The removal of large objects such as boxes, crates, cans, etc. or the need for a ladder to inspect a wastewater pre-treatment facility shall constitute a violation of Wastewater Control Ordinance Section 138-292 (d)

## VI. Acid Neutralization

All acid neutralization tanks shall be installed in accordance with Detail #305, Appendix A; Standards and Specifications Regarding Water, Sanitary Sewer and Storm Drainage Infrastructure, latest revision.

### A. Applicability

Those individuals engaged in activities where acids are used, or stored shall be required to install and maintain acid neutralization wastewater pre-treatment units. Only those drains which may receive acids intentionally or accidentally shall be connected to the neutralization unit.

### B. Materials and Structures

Acid neutralization units shall be made of vitrified clay, high-density polyethylene, polypropylene or other material specified by a manufacturer for a specific application and approved by the Director of Aurora Water.

Concrete units lined with “acid resistant materials” shall not be approved.

#### 1. Neutralization Media

Limestone chips or lumps are used in most acid wastewater pre-treatment units. These chips or lumps shall not be less than 1 inch or greater than 3 inches in any dimension.

#### 2. Other Chemical Wastewater Pre-treatment Methods



Other chemical wastewater pre-treatment methods exist and may be approved by the City of Aurora upon demonstration they are safe, conform to all applicable standards, and produce an effluent which is acceptable to the City of Aurora. These methods will be reviewed on a case-by-case basis and require written approval by Aurora Water prior to being installed or implemented.

### **C. Sizing**

Sizing of any acid neutralization unit shall be reviewed by Aurora Water and shall be as follows:

The number of sinks x 3.75 gallons per sink = Volumetric capacity of the unit (nearest size up).

In case a sink has more than one compartment, each compartment shall be considered a separate sink.

The smallest acid neutralization tank allowed shall be a five (5) gallon capacity unit.

### **D. Maintenance and Inspections**

1. Periodic operations and maintenance inspections shall be performed by Aurora Water to ensure compliance with the Wastewater Control Ordinance, these Rules and Regulations, and Wastewater Discharge Permits. It shall be the responsibility of those engaged in the operation of a business (commercial or industrial) activity to maintain their associated wastewater pre-treatment facilities in efficient functioning order.
2. Acid Neutralization units shall be inspected by their owners at least quarterly (3 months) to ensure the neutralization media is at its prescribed level. Maintenance and inspection records must be retained on site for a minimum of three (3) years.
3. Partial cleaning is not allowed.
4. Access to wastewater pre-treatment facilities shall remain unobstructed at all times. The removal of large objects such as boxes, crates, cans, etc. or the need for a ladder to inspect a wastewater pre-treatment facility shall constitute a violation of Wastewater Control Ordinance Section 138-292 (d).

## **VII. Typical Sand and Oil Interceptors**

All interceptors shall be installed in accordance with Detail #304, Appendix A; Standards and Specifications Regarding Water, Sanitary Sewer and Storm Drainage Infrastructure, latest revision.

#### Applicability

1. These rules and regulations shall apply to automotive/recreational service stations, truck or car wash facilities, vehicle maintenance facilities, mechanical repair shops, garden nurseries, warehouses, parking garages, machine shops, and other facilities where sand, oil, and/or hazardous wastes could enter the public sewer system.
2. Users with an elevator pit must either install a sand/oil interceptor or implement one of the other options outlined in Section IX of these Rules and Regulations.

### **A. Materials and Structures**

1. All sand and oil interceptors shall be two compartment, pre-cast concrete tanks. The smallest compartment shall have 1/3 the capacity of the entire interceptor.

### **B. Location**

All sand and oil interceptors shall be located outside, on private property, within thirty (30) feet and not less than five (5) feet from the facility served, unless otherwise approved by the Director of Aurora Water, and shall be accessible at all times for maintenance and inspection.

### **C. Sizing**

No combination sand and oil interceptor smaller than 750-gallon capacity shall be installed at a single bay facility.

The sizing shall be reviewed by the Aurora Water Department and shall be as follows:

Three (3) inch diameter flow drains are rated at six (6) drainage fixture units (DFU)

Four (4) inch diameter flow drains are rated at eight (8) DFU

Sizing formula shall be as follows:

DFU connected X 7.5 GPM X 5 minutes = Interceptor Size.

#### **1. Trough Drains**

Where trough drains are used, each bay, or compartment, or area equaling the square foot surface of a standard service station bay which is served by a trough drain shall be rated at six (6) DFU per bay.

#### **2. Vehicle Wash Drains**

Vehicle wash drains will be rated at eight (8) DFU each regardless of size.

## **D. Maintenance and Inspections**

1. Periodic operations and maintenance inspections shall be performed by Aurora Water to ensure compliance with the Wastewater Control Ordinance, these Rules and Regulations, and Wastewater Discharge Permits. It shall be the responsibility of those engaged in the operation of a business (commercial or industrial) activity to maintain their associated wastewater pre-treatment facilities in efficient functioning order.
2. Sand/oil interceptors shall be pumped and cleaned of their accumulated matter as often as necessary to ensure maximum efficiency and to prevent non-compliance with applicable discharge limitations.
3. A sand/oil interceptor is shall require service when settled solids and floating oil exceed 25% of the liquid capacity of either compartment of the tank
4. Aurora Water may require a business to maintain a specific sand/oil interceptor pumping and cleaning interval based on observed problems or non-compliance related to sand/oil production, accumulation and wastewater discharges.
5. Interceptor pumping, cleaning and hauling service companies hired to perform work for businesses in the City of Aurora must be properly accredited and licensed according to Colorado state law.
6. Maintenance and pumping records must be kept onsite for a minimum of three (3) years. Aurora Water reserves the right to require a business to routinely submit maintenance and pumping records to the City.
7. Partial cleaning of sand/oil interceptors is not allowed.
8. Biological, enzymatic, chemical treatments of wastewater flows are not.
9. Access to wastewater pre-treatment devices shall remain unobstructed at all times. The removal of large objects such as boxes, crates, cans, etc. or the need for a ladder to inspect a wastewater pre-treatment facility shall constitute a violation of Wastewater Control Ordinance Section 138-292 (d)

## **VIII. Trailer Courts and Mobile Home Parks**

1. All lot sanitary sewer drain inlets shall be extended not more than four (4) inches above ground. Mobile home lot drain inlets and extensions to grade shall be of material approved for underground use within a building.
2. All material used for sewer connections between a mobile home and the sanitary sewer inlet shall be rigid, corrosion resistant, non-absorbent, and durable. The inner surface shall be smooth.

3. Provisions shall be made for plugging or capping the lot sanitary sewer inlet when a mobile home does not occupy the lot.
4. Connections from the sanitary sewer drain outlet to the sanitary sewer lot drain inlet shall be water and airtight. When a mobile home lot is vacant, the drain on the lot shall be capped, so as to be water and airtight.

## **IX. Elevator Pits**

New users with elevator pits shall not have drains in those elevator pits connected directly to the sanitary sewer. Sump pumps may be installed in elevator pits. The requirement for a sump pump to be installed is to be determined by the building engineer, architect, or equivalent and/or as required by the local building authority.

In the event it is determined a sump pump shall be installed, there are three options to manage the discharge of accumulated wastewater from the sump:

1. If a sand/oil interceptor is already required in the facility (e.g., a parking garage, maintenance garage, or warehouse where floor drains are present), then the sump pump outlet may be plumbed through the sand/oil interceptor. A sand/oil interceptor may not be installed for the sole purpose of draining the elevator pit, because not enough wastewater will pass through the sand/oil interceptor to allow it to function as designed.
2. If a sump pump is to be plumbed to the sanitary sewer and a sand/oil interceptor is not required based on other infrastructure, an oil detector shall be installed which will shut-off the flow of wastewater and sound an alarm in the event oil is detected in the wastewater. In the event the oil detector shuts off wastewater flow and the alarm sounds, the wastewater in the elevator pit shall be handled as discussed below.
3. If the sump pump is not to be plumbed directly to the sanitary sewer, it may be plumbed to a holding reservoir. The size and structure of the holding reservoir is to be determined by the building engineer, architect, or equivalent and/or as required by the local building authority. Wastewater in the holding reservoir shall be handled as discussed below.
4. Wastewater may be continuously discharged to the sanitary sewer via a sump pump if the required oil detector described above is installed and maintained in working order. Below are approved options for handling wastewater in elevator pits where the oil detector alarm has been activated, wastewater accumulated at the bottom of a sump where there is no pump and no discharge, or wastewater in a holding reservoir:
  5. If the wastewater is to be discharged to the sanitary sewer, oil on the top of the water must be skimmed off or absorbed using oil absorbent pads or equivalent

and disposed of by an appropriate waste hauler. Following removal of the oil, if the wastewater is in an elevator pit, the remaining wastewater may be discharged to the sanitary sewer via the sump pump. If the wastewater is in a holding reservoir or at the bottom of a sump where there is no pump and no discharge, the wastewater may then be discharged to the sanitary sewer via appropriate means (i.e. hose, bucket transport, etc.).

6. Wastewater in either the elevator pit or holding reservoir may be containerized and hauled off-site by an appropriate waste hauler.
7. If the volume of wastewater accumulating in the bottom of a sump where there is no pump and no discharge or in a holding reservoir is limited and does not require discharge to the sanitary sewer or off-site disposal, the wastewater may be allowed to evaporate.

## **X. Venting**

Where the venting of an interceptor is connected to Building vent piping, the authority of the Aurora Water Department will stop just prior to this connection and vent piping shall be constructed per Aurora Building Division requirements

### **A. Vents not required**

Where permitted by the Aurora Water Department, vent piping may be omitted on an interceptor when such interceptor acts as a primary settling tank and discharges through a horizontal indirect waste pipe into a secondary interceptor. The second interceptor shall be properly trapped and vented.

### **B. Materials**

1. Vent pipe shall be cast iron, galvanized steel, galvanized wrought iron, lead, copper or brass. Where combustible construction is allowed, ABS and PVC vent pipe will be approved.
2. No galvanized wrought iron or galvanized steel pipe shall be used underground, but shall be kept at least six (6) inches above the ground.
3. Vent fittings shall be cast iron, galvanized steel, galvanized malleable iron, lead, copper, brass, ABS, PVC, except no galvanized iron or galvanized steel fitting shall be used underground but shall be kept at least six (6) inches above the ground.
4. Changes in direction of vent piping shall be made by the appropriate use of approved fittings and no such pipe shall be strained or bent. Burred ends shall be reamed to the full bore of the pipe.

### **C. Size of Vents**

The size of vent piping shall be determined from its length and the total number of fixture units connected thereto, as set forth below.

A vent may exceed 1/3 of the maximum horizontal length as limited by Table 3 only if the vent is increased one pipe size for its entire length.

#### **D. Vent Pipe Grades and Connections**

1. All vent and branch vent pipes shall be free from drops or sags and each such vent shall be level or shall be so graded and connected as to drip back by gravity to the drain pipe it serves.
2. Where vents connect to a horizontal drainpipe, each vent pipe shall be taken off the centerline of such pipe ahead of the trap being served.
3. Unless prohibited by structural conditions, each vent shall rise vertically to a point not less than six (6) inches above the flood level rim of the fixture served before offsetting horizontally, and whenever two or more vent pipes converge, each such vent pipe shall rise to a point at least six (6) inches in height above the flood level rim of the plumbing fixture its served before being connected to any other vent. When horizontal vents are less than (6) inches above flood level rim of the fixture, the horizontal portion shall be installed with approved drainage material.
4. All vent pipes shall extend undiminished in size above the roof, or shall be reconnected with a soil or waste vent of proper size. Weather heads will not be allowed.

#### **E. Vent Termination**

1. Each vent pipe or stack shall extend through its flashing and shall terminate vertically not less than ten (10) inches above the roof nor less than one (1) foot from any vertical surface.
2. Each vent shall terminate not less than ten (10) feet from or at least three (3) feet above any window, door, opening, air intake, or vent shaft, nor less than three (3) feet in any direction from any lot line; alley and street excepted.
3. Vent pipes shall be extended separately or combined of full required size, not less than ten (10) inches above the roof or firewall.
4. Vent pipes for outdoor installations shall extend at least ten (10) feet above the surrounding ground and shall be securely supported.
5. Joints around vent pipes shall be made watertight by the use of approved flashing or flashing material.

#### **Venting for Grease and Combination Sand and Oil Interceptors**

Pipe Size	Max. Drainage Fixture Units	Max. Lengths
1 ½"	1	45
1 ½"	8 (1)	60
2" (Min exterior vent size)	24	120
2 ½"	48	160
3" (2)	84	212
4"	256	300
5"	600	390
6"	1380	510

Note: (1) Except six-unit traps

(2) Minimum pipe diameter of inlet and outlet of Type A, B, and C grease interceptors, Type A and B combination Sand and Oil Interceptors.

Note: The diameter of an individual vent shall not be less than 1 ¼" nor less than one-half of the diameter of the drain to which it is connected.

## XI. Swimming Pools

These rules and regulations shall apply to discharges from swimming pools and all those private individuals, commercial and industrial firms. Swimming pool discharges are not allowed to enter the public sanitary sewer system unless approved by the Director of Aurora Water per Wastewater Control Ordinance Section 138-263 (c).

Any persons discharging swimming pool water to the storm or sanitary sewer system must first notify the Aurora Water Department by calling 303-326-8645.

Discharges of swimming pool water from pools other than residential pools may be subject to discharge permitting requirements of the state of Colorado. More information may be obtained from Water Quality Control Division of the Colorado Department of Public Health and the Environment (CDPHE) – 303-692-2000.

Aurora Water accepts no responsibility for damage resulting from the discharging of any swimming pool water. Any variation from this procedure will be considered a direct violation of Chapter 138 of Aurora Municipal Code and will be grounds for issuance of a Notice of Violation or Summons and Complaint by Aurora Water.

### A. Discharge to the Sanitary Sewer

1. Discharges of swimming pool water to the sanitary sewer system may require pre-authorization from the Metro Wastewater Reclamation District - 303-286-3000.
2. Backwash filter wastewater discharge shall be connected only to the sanitary sewer.
3. Wastewater pre-treatment prior to discharge may be required.

4. Draining pools to the sanitary sewer shall be accomplished only between the hours of 12 midnight and 6 am, or at a time established by the Director of Aurora Water.
5. The drain from the pool shall be permanently controlled to discharge no more than 0.5 cubic feet per second or 225 gpm.

## **B. Discharge to the Storm Sewer**

1. Swimming pool discharges shall not have a physical connection to the storm drain system.
2. All discharges of swimming pool water to the storm drain system must be de-chlorinated and filtered.
3. No swimming pool water shall be discharged where it will empty into a public right of way at a rate exceeding 225 gpm, or at any rate which endangers property of other owners.
4. No pool wastewater shall be discharged into the public right of way during freezing weather.
5. Pool water may be discharge to a vegetated area of the owner's property as long as neighboring properties are not adversely impacted, the discharge is diverted away from building foundations, and it does not cause erosion or nuisance conditions.



## **XII Metro Wastewater Reclamation District Discharge Limitations – Excerpt from Section 6, Rules and regulations Governing the Operation, Use and Services of the System**

### **6.13 GENERAL REQUIREMENTS REGARDING DELETERIOUS WASTES**

None of the following described Sewage, water, substances, materials or waste shall be discharged into the Metro District's System or the Sewer System of any Municipality by any Industrial User. These Requirements and prohibitions may be imposed directly on process wastewaters prior to dilution by domestic and other wastewaters discharged by the Industrial Users. Site-specific limitations and/or Best Management Practices may be developed and imposed on Industrial Users to ensure compliance with these *Rules and Regulations*.

1. Sewage of such a nature and delivered at such a rate as to impair the hydraulic capacity of the System, normal and reasonable wear and usage excepted.
2. Sewage of such a quantity, quality, or other nature as to impair the strength or the durability of the sewer structures, equipment or treatment works, either by chemical or by mechanical action.
3. Sewage having a flash point lower than 187°F, as determined by the test methods specified in 40 CFR §261.21.
4. Any radioactive substance, the discharge of which, does not comply with Section RH 4.35 of the Colorado *Rules and Regulations pertaining to Radiation Control* (Volume 6 of the Code of Colorado Regulations, 6 CCR 1007-1, Part 4, et seq.).
5. Any garbage other than that received directly into the Sewer System of a Municipality from domestic and commercial garbage grinders in dwellings, restaurants, hotels, stores, and institutions, by which such garbage has been shredded to such a degree so all particles will be carried freely under flow conditions normally prevailing in public sewers with no particle greater than one-half (1/2) inch in any dimension.
6. Any night soil or septic tank pumpage, except by permit in writing from the Metro District at such points and under such conditions as the District may stipulate in each permit.
7. Sludge or other material from sewage or industrial waste treatment plants or from water treatment plants, except such sludge or other material, the discharge of which to the System shall be governed by the provisions of this Agreement herein set forth or as otherwise authorized by the Metro District.
8. Water which has been used for cooling or heat transfer purposes without recirculation, discharged from any system of condensation, air conditioning, refrigeration, or similar use.
9. Water accumulated in excavations or accumulated as the result of grading, water taken from the ground by well points, or any other drainage associated with construction.

10. Any water or wastes containing grease or oil and other substances which will solidify or become discernibly viscous at temperatures between 32°F and 150°F except by permit in writing from the Metro District at such points and under such conditions as the District may stipulate in each permit.

11. Any wastes containing a corrosive, noxious, or malodorous material or substance which, either singly or by reaction with other wastes, is capable of causing damage to the System or to any part thereof, of creating a public nuisance, or a hazard, or of preventing entry into the sewers for maintenance and repair.

12. Any wastes containing concentrated dye wastes or other wastes which are either highly colored or could become highly colored by reacting with any other wastes, except by permission of the Metro District.

13. Any wastes which are unusual in composition; i.e., contain an extremely large amount of suspended solids or BOD; are high in dissolved solids such as sodium chloride, calcium chloride, or sodium sulfate; contain substances conducive to creating tastes or odors in drinking water supplies; otherwise make such waters unpalatable even after conventional water purification treatment; or are in any other way extremely unusual unless the Metro District determines such such wastes may be admitted to the System or shall be modified or treated before being so admitted.

14. Any substance which may cause the Metro District's effluent or any other product of the District such as residues, sludges or scums, to be unsuitable for reclamation and reuse or to interfere with the reclamation process. In no case, shall a substance discharged to the System cause the District to be in non-compliance with sludge use or disposal criteria, guidelines or regulations developed under Section 405 of the Federal Water Pollution Control Act; any criteria, guidelines, or regulations affecting sludge use or disposal developed pursuant to the Solid Waste Disposal Act, the Clean Air Act, the Toxic Substances Control Act, or State criteria applicable to the sludge management method being used.

15. Any substance which may cause the District to violate its National Pollutant Discharge Elimination System (NPDES) Permit or the receiving water quality standards.

16. Except for existing combined sewer facilities, any stormwater, directly or indirectly, from surface drains, ditches, or streams, storm or combined sewers, roof, areaway, sumps and sump pumps, or foundation drains, or from any other means, including subsurface drainage or groundwater.

17. Any water or wastes potentially contaminated with (1) transmissible spongiform encephalopathy agents from diseases such as chronic wasting disease, bovine spongiform encephalopathy, scrapie, Creutzfeldt-Jakob disease, (2) foot-and-mouth disease agents, or (3) anthrax, except by permission of the Metro District.

#### **6.14 PROHIBITED DISCHARGES**

None of the following described Sewage, water, substances, materials, or wastes shall be discharged into the Metro District's System or into the Sewer System of any Municipality, by any Industrial User. These Requirements and prohibitions may be imposed directly on process wastewaters prior to dilution by domestic and other wastewaters discharged by the Industrial Users. Site-specific limitations and/or Best Management Practices may be developed and imposed on Industrial Users to ensure compliance with these *Rules and Regulations*.

1. Any liquids, solids or gases which by reason of their nature or quantity are, or may be, sufficient either alone or by interaction with other substances to cause fire or explosion or be injurious in any other way to the Metro District's System, the Sewer System of a Municipality or any of its Connectors, or to the operation of the District. At no time shall any reading on an explosion hazard meter, at the point of discharge into the District's System or the Sewer System of a Municipality or any of its Connectors (or at any point in the Systems), or at any monitoring location designated by the District in a Wastewater Discharge Permit, be more than ten percent (10%) of the Lower Explosive Limit (LEL) of the meter. Prohibited materials include, but are not limited to, gasoline, kerosene, naphtha, benzene, toluene, xylene, ethers, alcohols, ketones, aldehydes, peroxides, chlorates, perchlorates, bromates, carbides, hydrides, and sulfides
2. Any solid or viscous material which could cause an obstruction to flow in the sewers or in any way could interfere with the treatment process, including as examples of such materials but without limiting the generality of the foregoing, significant proportions of ashes, wax, paraffin, cinders, sand, mud, straw, shavings, metal, glass, rags, lint, feathers, tars, plastics, wood and sawdust, paunch manure, hair and fleshings, entrails, lime slurries, beer and distillery slops, grain processing wastes, grinding compounds, acetylene generation sludge, chemical residues, acid residues, food processing bulk solids, snow, ice, and all other solid objects, material, refuse, and debris not normally contained in sanitary sewage.
3. Any wastewater having a pH less than 5.0 for discharges from Industrial Users into the Metro District's System or the Sewer System of a Municipality or that of any of its Connectors, or less than 6.0 or greater than 9.0 for other discharges into the District's System, or wastewater having any other corrosive property capable of causing damage or hazard to any part of the District's System or the Sewer System of a Municipality or any of its Connectors, or to personnel.
4. Any wastewater having a temperature which will inhibit biological activity at the District's treatment plant, but in no case wastewater containing heat in such amounts the temperature at the introduction into the District's treatment plant exceeds 40°C (104°F).
5. Any pollutants, including oxygen demanding pollutants (BOD, etc.) released at a flow rate and/or pollutant concentration which cause Pass Through or Interference. In no case shall a slug load have a flow rate or contain concentrations or qualities of pollutants that exceed for any time period longer than fifteen (15) minutes more than five (5) times the average twenty-four (24) hour concentration, quantities, or flow during normal operation.
6. Any water or wastes containing a toxic substance in sufficient quantity, either singly or by interaction with other substances, to injure or interfere with any sewage treatment process, to constitute a hazard to humans or to animals, or to create any hazard or toxic effect in the waters which receive the treated or untreated sewage.
7. Petroleum oil, non-biodegradable cutting oil, or products of mineral oil origin, each in amounts that will cause Interference or Pass Through.
8. Pollutants which result in the presence of toxic gases, vapors, or fumes within the system in a quantity that may cause acute worker health and safety problems.
9. Any trucked or hauled pollutants except at discharge points designated by the Metro District.
10. Any water or wastes containing Pollutant quantities or concentrations exceeding the limitations in Section 6.18 of these *Rules and Regulations* or the limitations in any applicable Categorical Standards.

11. Any wastewater discharges to the Metro District's System, except at locations approved by the Metro District.

12. Solids, sludges, filter backwash, or other Pollutants removed in the course of treatment or control of wastewaters (including, but not limited to, materials which have been removed by catch basins, grease traps, sand traps or pre-treatment systems/devices), or acquired from another person or location.

13. Wastewater which alone or in conjunction with other sources causes the Metro District's effluent to fail toxicity testing.

14. Detergents, surface-active agents or other substances which alone or in conjunction with other sources cause excessive foaming in the collection system or at the treatment plant.

#### **6.15 SPECIFIC DISCHARGE LIMITATIONS - MUNICIPALITIES**

No Municipality shall discharge to the System at any time or over any period of time wastewater containing any of the following materials and substances in excess of the limitations provided herein:

Limit mg/L

1. Cyanides (as HCN) 2
2. Oil and Grease (Hexane or approved solvent extractable) 75
3. Phenolic compounds (as Phenol) 10
4. Sulfides (as H<sub>2</sub>S) 10

#### **6.16 RESERVED**

#### **6.17 GENERAL DISCHARGE PROHIBITIONS**

No Industrial User shall contribute or cause to be contributed, directly or indirectly, any Pollutant or wastewater which will Pass Through or Interfere with the operation or performance of the Metro District. These general prohibitions apply to all Industrial Users of the System whether or not the Industrial User is subject to National Categorical Pre-treatment Standards or any other national, State, district, or local Pre-treatment Standards or Requirements: Industrial Users may not discharge any of the Sewage, water, substances, materials, or wastes listed in Sections 6.13 or 6.14 of these *Rules and Regulations*. These requirements and prohibitions may be imposed directly on process wastewaters prior to dilution by domestic and other wastewaters discharged by the Industrial Users. Site-specific limitations and/or Best Management Practices may be developed and imposed on Industrial Users to ensure compliance with these *Rules and Regulations*.

#### **6.18 SPECIFIC DISCHARGE LIMITATIONS - USERS**

**6.18.1 Metro District Limitations.** No Industrial User shall discharge into the System or into any Sewer System at any time or over any period of time, wastewater containing any of the following materials and substances in excess of the limitations provided herein. These limitations may also be imposed directly on process wastewaters prior to dilution by domestic and other wastewaters discharged by the Industrial User:

Limit mg/L

1. Arsenic 0.33

2. Cadmium 3.4
3. Chromium 3.6
4. Copper 6.1
5. Lead 2.2
6. Mercury 0.13
7. Molybdenum 0.43\*
8. Nickel 5.6
9. Selenium 0.66
10. Silver 2.9
11. Tetrachloroethene 1.5\*\*
12. Zinc 15.6

\* Notwithstanding this numeric limitation, effective January 1, 2007, discharge from cooling towers, boilers, closed-loop heat transfer systems and any other cooling/heating system treated with molybdenum-containing water treatment chemicals is prohibited entirely. Where necessary, the Metro District may require that these wastes be physically prevented from discharging into the sanitary sewer system.

\*\* Notwithstanding this numeric limitation, the discharge of dry-cleaning process wastes, including new and used tetrachloroethene (perchloroethylene), still bottom oil, and separator water, is prohibited entirely. Where necessary, the Metro District may require that these wastes be physically prevented from discharging into the sanitary Sewer System

**6.18.2 National Pre-treatment Standards and Requirements.** Once promulgated, Categorical Standards for a particular industrial subcategory, if more stringent, shall supersede all conflicting discharge limitations contained in this Section 6, as they apply to that industrial subcategory. All Industrial Users must comply with all applicable National Pre-treatment Standards and Requirements.

**6.18.3 State Requirements.** State requirements and limitations on discharges shall apply in any case where they are more stringent than federal requirements and limitations or those contained elsewhere in this Section 6.

**6.18.4 Dilution Prohibited.** Except where permitted by Categorical Standards, no Industrial User may increase the use of process water or, in any way, attempt to dilute a discharge as a partial or complete substitute for adequate treatment to attain compliance with the limitations contained in National Categorical Pre-treatment Standards or any other specific discharge limitations contained in this Section 6. The Metro District may set or require a Municipality to set mass limitations or alternate concentration-based limitations for those Industrial Users which are using improper dilution to meet these limitations.

## **XIII City of Aurora Code Discharge Limitations – Excerpt from Section 138-263 Use of Public Sewers**

Sec. 138-263. Use of public sewers.

(a) *Rules and regulations.* It shall be the responsibility of the director of water to formulate rules and regulations governing the discharge of wastewater to the POTW consistent with this article.

(b) *Discharge of drainage and unpolluted waters.* It shall be unlawful for any person to discharge or cause to be discharged, any stormwater, surface water, groundwater, roof runoff, subsurface drainage, uncontaminated cooling water or unpolluted industrial process waters into any sanitary sewer. Stormwater and all other unpolluted drainage shall be discharged to such drains which are specifically designated as storm drains or to a natural outlet approved by the director of water. Industrial cooling water or unpolluted process waters may be discharged, on approval of the director, to a storm sewer or natural outlet.

(c) *Swimming pools.* Persons operating swimming pools which are connected directly or indirectly to the public sewer system shall drain those pools only in accordance with the drainage schedule established by the director of water. Such persons shall also notify the director of water at least 24 hours before draining their pools.

(d) *General discharge prohibitions.*

(1) No person shall contribute or cause to be contributed, directly or indirectly, any pollutant or wastewater which interferes with the operation or performance of the POTW.

(2) No person shall contribute the following substances to the POTW:

a. Any liquids, solids or gases which by reason of their nature or quantity are or may be sufficient, either alone or by interaction with other substances, to cause fire or explosion or be injurious in any other way to the POTW or to the operation of the POTW. Prohibited materials include but are not limited to gasoline, kerosene, naphtha, benzene, toluene, xylene, ethers, alcohols, ketones, aldehydes, peroxides, chlorates, perchlorates, bromates, carbides, hydrides and sulfides.

b. Solid or viscous substances which may cause obstruction to the flow in a sewer or other interference with the operation of the wastewater treatment facilities, such as but not limited to grease, garbage with particles greater than one-half inch in any dimension, animal entrails or tissues, paunch manure, bones, hair, hides or fleshings, whole blood, feathers, ashes, cinders, sand, spent lime, stone or marble dust, metal, glass, straw, shavings, grass clippings, rags, spent grains, spent hops, wastepaper, wood, plastics, tar, asphalt residues from refining or processing of fuel or lubricating oil, mud or glass grinding or polishing wastes.

c. Any wastewater containing toxic pollutants, hazardous wastes as defined by the Resource Conservation and Recovery Act, whether or not they are considered to be hazardous after entering the POTW, or poisonous substances in sufficient quantity, either singly or by interaction with other

pollutants, to injure or interfere with any wastewater treatment process, constitute a hazard to humans or animals, create a toxic effect in the receiving waters of the POTW, or exceed the limitation set forth in a categorical standard.

d. Sewage of such a nature and delivered at such a rate as to impair the hydraulic capacity of the system, or any part thereof; normal and reasonable wear and usage excepted.

e. Sewage of such a quantity, quality, or other nature as to impair the strength or the durability of the sewer structures, equipment or treatment works, either by chemical or by mechanical action.

f. Any night soil or septic tank pumpage, except by permit in writing from the director of water at such points and under such conditions as the director may stipulate in each permit.

g. Sludge or other material from sewage or industrial waste treatment plants or from water treatment plants, except when authorized by the director of water.

h. Water which has been used for cooling or heat transfer purposes without recirculation, discharged from any system of condensation, air conditioning, refrigeration, or similar use.

i. Water accumulated in excavations or accumulated as the result of grading, water taken from the ground by well points, or any other drainage associated with construction.

j. Any water or wastes containing grease or oil or other substances that will solidify or become discernibly viscous within a temperature range set forth in the rules and regulations promulgated by the director of water.

k. Any wastes that contain a corrosive, noxious, or malodorous material or substance which, either singly or by reaction with other wastes, are capable of causing damage to the system or to any part thereof, of creating a public nuisance or hazard, or of preventing entry into the sewers for maintenance and repair.

l. Any wastes which are unusual in composition, i.e., contain an extremely large amount of suspended solids or BOD; are high in dissolved solids such as sodium chloride, calcium chloride, or sodium sulfate; contain substances conducive to creating tastes or odors in drinking water supplies; otherwise make such waters unpalatable even after conventional water purification treatment; or are in any other way extremely unusual unless the director of water determines that such wastes may be admitted to the system or shall be modified or treated before being so admitted.

m. Any wastes that contain excessive, as determined by the director of water, dye waste or others that are either highly colored or could become highly colored by reacting with any other wastes.

n. Any substance which may cause the POTW's effluent or any other product of the POTW, such as residues, sludges or scums to be unsuitable for reclamation and reuse or to interfere with the reclamation processes. In no case shall a substance discharged to the POTW cause the POTW to be in noncompliance with sludge use or disposal criteria, guidelines or regulations developed pursuant to the Solid Waste Disposal Act, the Resource Conservation and Recovery Act, the Clean Air Act, the

Toxic Substances Control Act, the Marine Protection, Research and Sanctuary Act, or more stringent state or local criteria, guidelines, or regulations applicable to the sludge management method being used.

o. Any substance which will cause the POTW to violate its NPDES permit or the receiving water quality standards.

p. Any wastewater having a temperature which will inhibit biological activity in the POTW treatment plant resulting in interference, but in no case wastewater containing heat or capable of creating heat in such amounts that the temperature at the introduction into the POTW treatment plant exceeds 40 degrees Celsius (104 degrees Fahrenheit).

q. Any pollutants, including oxygen demanding pollutants (BOD), etc., released at a flow rate and/or pollutant concentration which will cause pass through or interference. In no case shall a slug discharge have a flow rate or contain concentrations or qualities of pollutants that exceed for any time period longer than 15 minutes more than five times the average 24-hour concentration, quantities, or flow during normal operation.

r. Any wastewater containing any radioactive wastes or isotopes of such half-life or concentration as may exceed limits established by the director of water in compliance with applicable metro district, state or federal regulations.

(3) The prohibitions in subsection (d)(2) of this section shall apply to all users of the POTW whether or not the user is subject to national categorical pre-treatment standards or any other national, state, or local pre-treatment standards or requirements.

(4) When the director of water determines that a user is contributing any of the enumerated substances in subsection (d)(2) of this section or others not enumerated to the POTW in such amounts as to interfere with the operation of the POTW, the director shall:

a. Advise the user of the impact of the contribution on the POTW; and

b. Develop effluent limitations for such user to correct the interference with the POTW.

(5) If any user violates this subsection, nothing in this subsection shall limit the authority of the director of water to seek enforcement of this subsection against the user pursuant to section 138-293.

(e) *National categorical pre-treatment standards.* Upon the promulgation of a national categorical pre-treatment standard for a particular industrial subcategory, if more stringent limitations than those imposed under this article for sources in particular subcategory are promulgated, the national standard shall immediately supersede the limitations imposed under this article. The director shall notify all affected users of the applicable reporting requirements under 40 CFR 403.12.

(f) *Specific pollutant discharge standards.* Specific pollutant discharge standards are to be set forth by the director of water in the rules and regulations governing pollutant discharge and wastewater control.



(g) *State requirements.* State requirements and limitations on discharges shall apply in any case where they are more stringent than federal requirements and limitations or those in this article.

(h) *City's right of revision.* The city reserves the right to establish more stringent limitations or requirements on discharges to the POTW if deemed necessary to comply with the objectives presented in section 138-258.

(i) *Excessive discharge.* No user shall ever increase the use of process water or, in any way, attempt to dilute a discharge as a partial or complete substitute for adequate treatment to achieve compliance with the limitations contained in the national categorical pre-treatment standards, or in any other pollutant specific limitation developed by the city or state.

(j) *Accidental discharges.* Each user shall provide protection from accidental discharge of prohibited materials or other substances regulated by this article. Facilities to prevent accidental discharge of prohibited materials shall be provided and maintained at the owner's or user's own cost and expense. Detailed plans showing facilities and operating procedures to provide this protection shall be submitted to the city for review and shall be approved by the city before construction of the facility. All existing users shall complete such a plan by July 1, 1983. No user who commences contribution to the POTW after the effective date of this division shall be permitted to introduce pollutants into the system until accidental discharge procedures have been approved by the city. Review and approval of such plans and operating procedures shall not relieve any user from the responsibility to modify the user's facility as necessary to meet the requirements of this article. In the case of any accidental or unusual discharge, the user shall immediately telephone and notify the city and the metro district of the incident. The notification shall include the location, type, concentration, and volume of discharge, and corrective actions.

(k) *Written notice.* Within five days following an accidental discharge, the user shall submit to the director a detailed written report describing the cause of the discharge and the measures to be taken by the user to prevent similar future occurrences. Such notification shall not relieve the user of any expense, loss, damage, or other liability which may be incurred as a result of damage to the POTW, fish kills, or any other damage to person or property nor shall such notification relieve the user of any fines, civil penalties, or other liability which may be imposed by this article or other applicable law.

(l) *Notice to employees.* A notice shall be permanently posted on the user's bulletin board or other prominent place advising employees whom to call if an accidental discharge occurs. Employers shall ensure that all employees, who may cause or suffer such an accidental discharge to occur, are advised of the emergency notification procedure.

(Code 1979, § 39-104; Ord. No. 2005-74, § 1, 10-10-2005)

**THIS PAGE IS INTENTIONALLY BLANK**

## **APPENDIX D: IRRIGATION SYSTEM STANDARDS AND INSPECTIONS**

- I. PLAN REVIEW AND INSPECTION PROCEDURES
- II. IRRIGATION PLAN CHECKLIST
- III. IRRIGATION EQUIPMENT
- IV. IRRIGATION EQUIPMENT EXAMPLE
- V. IRRIGATION PLAN CHART EXAMPLES
- VI. IRRIGATION ORDINANCE

## I. PLAN REVIEW AND INSPECTION PROCEDURES

The City of Aurora Ordinance No. 2004-75, Irrigation Standards Sec. 138-192 irrigation plan submittal for all multi-family, commercial and common open space development. Irrigation plan review is not required for single family detached homes, however single family detached homes will be required to comply with the approved irrigation materials outlined in the ordinance and be subject to permitting and inspection.

**Step 1:** Design the irrigation plan(s) based on the approved stamped landscaping plans. Follow the irrigation plans checklist (page 2 attached).

**Step 2:** Schedule a pre-submittal meeting with Water Conservation (303-739-7351). The pre-submittal meeting is recommended but not mandatory prior to plan submission.

**Step 3:** Submit the irrigation design(s) based on approved stamped landscaping plans to the Irrigation Plans Examiner located at 15151 East Alameda Parkway, Suite 3600. Be sure to include at least (1) one copy of the approved stamped landscaping plans with the irrigation plans. *All irrigation plans must be reviewed before issuance of the building permit.* Electronic copies of plans are encouraged (AutoCAD .DWG, .DWF, Adobe .PDF or Image file .JPG or .TIF format) but not required until final submittal.

There is a per sheet fee for the irrigation plans review (corresponding landscaping plans will not be assessed this fee, just the irrigation sheets.) Please make checks payable to "City of Aurora". Checks can be mailed to the above address. Check [www.aurorawater.org](http://www.aurorawater.org) for the current irrigation plans review fee.

Please allow approximately 2 months (depending on size) for irrigation plan review.

**Step 4:** Upon final approval of irrigation plans, submit final approved irrigation plans in electronic form (AutoCAD .DWG, Adobe .PDF or Image file .JPG or .TIF format) to the Irrigation Plans Examiner. The approved irrigation plans will be digitally stamped approved by the irrigation plans examiner and returned to the responsible party who submitted the plans.

**Step 5:** Submit the irrigation permit application to the Lawn Permit Technician located at E. Alameda Pkwy, Suite 3600, Aurora, CO 80012.

**Step 6:** After installation of the irrigation system, call 303-739-7351 to obtain a permit and schedule an inspection. A City of Aurora inspector will perform the inspection prior to issuance of the Certificate of Occupancy. *All irrigation systems must be inspected before issuance of the Certificate of Occupancy.*

Please direct any questions to: Water Conservation Division  
Phone: 303-739-7351

### Irrigation Construction Plan Review Schedules

Irrigation Construction Plans	Up to 5 Sheets	Up to 10 Sheets	11+ Sheets
1st Aurora review	10 days	15 days	20 days
Consultant revisions on 1st round	5 days	5 days	5 days
2nd Aurora review*	10 days	10 days	10 days
Consultant revisions on 2nd round	5 days	5 days	5 days
3rd Aurora review	5 days	5 days	5 days
<b>TOTAL weeks</b>	<b>7 weeks</b>	<b>8 weeks</b>	<b>9 weeks</b>

## II. IRRIGATION PLAN CHECKLIST

Include all of the following information in the irrigation design plans:

1. The City approved landscape plans must be included with the submitted irrigation design plan.
2. Plans must be 24"x36" and at a scale of 1"=40' or greater. The drawing must be the same scale as the corresponding approved landscape plans.
3. The Irrigation Design Plan shall accurately and clearly identify:
  - Property boundaries, existing and future right of way lines.
  - North arrow, title block with name of project, sheet name, company identification including address, phone number and name of person preparing plan and date.
  - Graphical and written scale - sheet size and scale to match the approved landscape plan(s).
  - Existing and proposed structures and paving.
  - Proposed grades or spot elevations in sloped or bermed areas.
  - Location, model and size of all components of the irrigation system along with typical detail sheet.
  - Static water pressure at the point of connection.
  - Each zone or station shall list the:
    - o Zone number.
    - o Design operating pressure.
    - o Flow rate.
    - o Application rate (inches per hour).
  - Location, number and size of water tap(s), meter(s) and backflow preventer(s).
  - Location and size of each hydrozone (low, moderate, high) showing:
    - o Square footage of turf areas.
    - o Square footage of planting bed areas.
    - o Site water requirements.
    - o Method of irrigation used for each hydrozone (sub-surface, drip, microspray, pop up, rotor).
  - Table C. Calculated Annual Irrigation Water Use located on page 9, number (9) in Ordinance No. 2004-75, Irrigation Standards Sec. 138-192. (See example below)
  - Any zone(s) using non-potable water.
  - Seasonal maintenance schedule.
4. Irrigation designs for sites with greater than 1 1/2" meters must also accurately and clearly include in addition to the above requirements:
  - Pressure loss worksheet.
  - Irrigation schedule showing total run times, zone run times, number of cycles, frequency of irrigation for each zone.

### EXAMPLE: TABLE C. CALCULATED ANNUAL IRRIGATION WATER USE

Area in Turf (SF)	Area in Turf X 28 in. X 0.623 = Gallons Applied	Area in Plant Beds (SF)	Area in Plant Beds X 15 in. X 0.623 = Gallons Applied
10,000 (SF)	174,440 (Gallons Applied)	5,000	46,725 (Gallons Applied)
<b>Total Annual Gallons Applied Turf +Plant Beds</b>		<u>221,165</u> <b>Total Annual Gallons</b>	

### III. IRRIGATION EQUIPMENT

Per Ordinance No. 2004-75, Irrigation Standards Sec. 138-192 (single-family detached and duplex) development does not require irrigation plans review, but does require adherence to equipment requirements and inspection after irrigation installation for all irrigation installations. The following sections from the ordinance describe what is required in terms of irrigation materials:

#### (8) Equipment Selection.

##### **(a) Spray Heads**

Pop-up spray heads for turf areas shall have a minimum pop-up height of four inches. A six-inch pop-up height shall be used adjacent to streets. The 12" pop-up height shall be used in ground cover and flowerbeds. Heads shall seal in the operating position at 10 PSI or less, and the water used in the flush mode shall not exceed .05 gpm. Heads shall have a ratcheting feature for adjusting the direction of spray. Pop-up spray heads shall have built in check valves and a pressure-regulating device (set at 30 psi) installed in the base of the stem, a check valve installed in the base of the body, and under slotted plastic nozzles, with matched precipitation rate nozzles.

##### **(b) Rotary Heads.**

Rotary heads shall be internally driven, have a closed-case rotor with wiper seals that is spring retracted. The pop-up stem surface diameter shall be less than 2 inches, and have a minimum pop-up height of 4-inches. All heads shall have check valves built into the bottom of the body. Small radius rotor heads shall be used for areas that range from 20 feet to 30 feet wide.

##### **(c) Automatic Rain Shut-off Devices.**

All systems shall be equipped with an automatic rain shut-off device.

##### **(d) Automatic Controllers.**

The following features shall be incorporated into the controller:

- Multiple programs/start times
- Water budgeting and/or spray and soak features
- Memory retention
- Battery backup
- Flexible day programming for any intervals

##### **(e) Drip Irrigation.**

Drip Irrigation is defined as subsurface low volume systems that apply water in gallons per hour (GPH) through either calibrated pressure compensating emitters, bubblers, micro-spray and/or micro-spray pop-ups directly to a plant's root system or to a planted area.

- Self-flushing, pressure-compensating subsurface drip irrigation is recommended in all planting beds that are mulched or in narrow turf strips where spray heads are not practical. All subsurface drip shall be installed in the soil, not on the surface.
- As with sprinkler irrigation, drip irrigation shall be zoned for varying plant needs, slopes, and exposures.

##### **(f) Backflow Prevention Devices.**

All Irrigation systems shall be equipped with an appropriate backflow prevention device.

The City of Aurora requires the irrigation system to be inspected prior to the issuance of the Certificate of Occupancy. The City will be inspecting the following:

- Installation of irrigation system per approved irrigation plans.
- Equipment types (controllers, rain shut-offs, heads, etc.)
- Proper installation of equipment. (Including proper head usage, spacing, types on ones, alignment depth, etc.)
- Spray coverage.
- Controller program watering schedule.

## IV. IRRIGATION EQUIPMENT EXAMPLE

Please note: The City of Aurora does not endorse or recommend one type of irrigation material over another and recommends that each potential applicant understands the city's requirements before choosing a product or contractor. This is not a complete list but an example of what materials meet the ordinance. Other materials will be considered if they meet the minimum requirements.

<u>Pop-Up Heads</u>			<u>Rain Sensors</u>		
<b>Manufacturer</b>	<b>Model</b>	<b>Description</b>	<b>Manufacturer</b>	<b>Model</b>	<b>Description</b>
HIT Prod Corp	900 Series-CKV-PRD	Spray Head (4" min law n 12" min. beds)	Hunter	Mini-Clik	Rain Sensor
Hunter	Institutional Spray Sprinkler	Spray Head (4" min law n 12" min. beds)	Hunter	Rain Clik	Rain Sensor
	With Check Valve		Rainbird	Rain Check	Rain Sensor
Hunter	MPR40-CV w/Check Valve	Spray Head (4" min law n 12" min. beds)	Rainbird	WRS Series	Rain Sensor
Irritrol	I-Pro-400(600 & 1200)-PR-CV	Spray Head (4" min law n 12" min. beds)	Toro	Law n Master Rain Sensor	Rain Sensor
Rainbird	1800-SAM-PRS	Spray Head (4" min law n 12" min. beds)			
Toro	570Z-PRX	Spray Head (4" min law n 12" min. beds)			
<u>Rotor Heads</u>					
<b>Manufacturer</b>	<b>Model</b>	<b>Description</b>			
Hunter	PGJ-04-V w/Check Valve				
Hunter	PGP-04-V w/Check Valve				
Hunter	I-10/I-20	-ADV; -36V; -ADS; -36S; -ARV; -3RV			
Rainbird	5004-SAM	-SAM			
Rainbird	5000 Plus	-SAM			
Rainbird	5500-SAM	-SAM			
Rainbird	7005				
Rainbird	8005				
Rainbird	3500-SAM	-SAM			
Weathermatic	T3				
Weathermatic	CT70				
<u>Controllers</u>			<u>Controllers (continued)</u>		
<b>Manufacturer</b>	<b>Model</b>	<b>Description</b>	<b>Manufacturer</b>	<b>Model</b>	<b>Description</b>
Champion	Water Champ	Irrigation Controller	Orbit	Control Center	Irrigation Controller
Hunter	ACC	Irrigation Controller	Rainbird	ESP-LX Plus	Irrigation Controller
Hunter	ICC	Irrigation Controller	Rainbird	ESP-MC	Irrigation Controller
Hunter	Pro-C	Irrigation Controller	Rainbird	IM	Irrigation Controller
Irritrol	Dial Series	Irrigation Controller	Rainmaster	Eagle	Irrigation Controller
			Rainmaster	Evolution DX2	Irrigation Controller
Irritrol	IBOC Series	Irrigation Controller	Rainmaster	Sentar II	Irrigation Controller
Irritrol	Junior Max	Irrigation Controller	Toro	DDC	Irrigation Controller
Irritrol	KwikDial Series	Irrigation Controller	Toro	Greenskeeper	Irrigation Controller
Irritrol	MC Plus Series	Irrigation Controller	Toro	Intelli-Sense	Irrigation Controller
Irritrol	Rain Dial Plus Series	Irrigation Controller	Toro	TurfPro	Irrigation Controller
Irritrol	Smart Dial	Irrigation Controller	Toro	Vision II	Irrigation Controller
Irritrol	Total Control Series	Irrigation Controller	Weathermatic	LMC	Irrigation Controller
Nelson	EZ Pro	Irrigation Controller	Weathermatic	Residential Controller	Irrigation Controller
Nelson	EZ Pro Turf Jr.	Irrigation Controller	Weathermatic	SL	Irrigation Controller
Netafim	Miracle DC	Irrigation Controller	Weathermatic	VAC	Irrigation Controller
Nelson	Smart Zone EZ	Irrigation Controller			



## V. IRRIGATION PLAN CHART EXAMPLES

<b>CONTROLLER CHART 'A'</b>									
<b>IF LARGER THAN 1 ½" METER INCLUDE BOLD COLUMNS</b>									
Zone No.	Plant Type	Zone Description	Prec. in/hr	Zone flow GPM	Peak rate per week	<b>Weekly zone run time hours</b>	<b>Daily zone run time minutes</b>	<b>Water usage gallons per week</b>	Design operating pressure psi
A1	ShrubsDrip		0.50	4	1.00	<b>2.00</b>	<b>40.00</b>	<b>480</b>	30.00
A2	ShrubsDrip		0.50	4	1.00	<b>2.00</b>	<b>40.00</b>	<b>480</b>	30.00
A3	Native Rotors		0.57	17	1.00	<b>1.75</b>	<b>35.09</b>	<b>1,768</b>	50.00
A4	Turf Pop-Up (15')		1.83	18	1.80	<b>0.98</b>	<b>19.67</b>	<b>1,091</b>	30.00
A5	Turf Pop-Up (8')		1.83	7	1.80	<b>0.98</b>	<b>19.67</b>	<b>436</b>	30.00
A6	Turf Pop-Up (15')		1.83	26	1.80	<b>0.98</b>	<b>19.67</b>	<b>1,527</b>	30.00
A7	Turf Pop-Up (10')		1.75	20	1.80	<b>1.03</b>	<b>20.57</b>	<b>1,255</b>	30.00
A8	Turf Pop-Up (12')		2.01	31	1.80	<b>0.90</b>	<b>17.91</b>	<b>1,689</b>	30.00
A9	Turf Pop-Up (8')		1.83	11	1.80	<b>0.98</b>	<b>19.67</b>	<b>654</b>	30.00
A10	Native Rotors I-20 (#6.0)		0.57	11	1.00	<b>1.75</b>	<b>35.09</b>	<b>1,179</b>	50.00
A11	Native Rotors I-20 (#3.0SR)		0.78	36	1.00	<b>0.93</b>	<b>18.69</b>	<b>1,996</b>	50.00
A12	ShrubsDrip		0.50	4	1.00	<b>2.00</b>	<b>40.00</b>	<b>480</b>	30.00
Total projected peak season water use per week (gallons)								<b>13,036</b>	
Total peak season hours per week - Controller 'A'						<b>16.65</b>			
Number of days/week						3			
Two (2) starts per day									

## SEASONAL WATER USE AND PEAK FLOW PROJECTION EXAMPLE

- Property Name: EXAMPLE
- Project Location: AURORA
- Seasonal Water Use and Peak Flow Projections-City of Aurora
- Prepared By: EXAMPLE
- Date: 30-Nov-05

Description	Irrigat Acres	Month	App Rat % (in/ Adj)	Monthl water (gallon)	Maximu Require Flow-
• Irrigated Turf		April	1.72 26	11,676	
• Bluegrass Sod		May	3.42 52	23,217	
		June	5.25 80	35,640	
	0.25	July	6.60 100	44,804	15
		August	5.75 87	39,034	
		September	3.45 52	23,420	
		October	1.71 26	11,608	
• Annual sub-total			27.9 /yr	189,40 /yr	
				0.58 acrefeet	
• Irrigated		April	0.90 25	48,877	
• Native Seed &		May	1.80 50	97,755	
		June	2.80 78	152,06	
	2	July	3.60 100	195,51	65
		August	3.10 86	168,35	
		September	1.90 53	103,18	
		October	0.90 25	48,877	
• Annual sub-total			15.0 /yr	814,62 /yr	
				2.50 acrefeet	
• Site Totals	2.25 irrigated acres			1,004,02 gals/yr	
				3.08 acrefeet/yr	
				80 GPM-peak	

• Projections are based on a three day per week, six hour per day peak season watering schedule. Peak season application for bluegrass is 1.8" per week. Peak season application for spray irrigated shrubs and native grass is 0.80" per week.

**IF LARGER THAN 1 ½" METER INCLUDE:**

*PRESSURE LOSS CHART EXAMPLE*

Property Name:	EXAMPLE							
Project Location:	AURORA							
Irrigation System Hydraulic Worksheet								
Prepared By:	example							
	Date 12.2.05							
Static Water Pressure:	75.00	From:						
		of:	City of Aurora					
<b>Hydraulic Grade:</b>								
(Measured from backflow to valve X10)							Flow-GPM	Loss/Gain
Svc Line:	20	LF	3"	K Copper	6.10	/ 100 FT	80.00	1.22
Water Meter:			3"				80.00	6.51
Svc Line:	30	LF	3"	K Copper	6.10	/ 100 FT	80.00	1.83
Backflow:			3"	Febco 825YA Series			80.00	12.50
Master Valve:							0.00	0.00
Pressure Required at Head:				Rainbird Series				30.00
Lateral Allowance:								3.50
Control Valve Allowance:								3.40
Mainline Allowance:								
@80GPM	25	LF	3"	CL200BE	0.52	/ 100 FT		0.13
@40GPM	1285	LF	2.5"	CL200BE	0.38	/ 100 FT		4.88
						/ 100 FT		0.00
Elevation								
Tap Elevation	5106		High/Low		5116			4.33
Total System requirements (PSI)								68.30
Available Pressure (PSI)								75.00

## VI. IRRIGATION ORDINANCE

### ORDINANCE NO. 2004-75

#### A BILL

#### FOR AN ORDINANCE AMENDING CHAPTER 138 OF THE CITY CODE OF THE CITY OF AURORA, COLORADO RELATING TO IRRIGATION STANDARDS

---

WHEREAS, pursuant to section 138-188 of the Aurora City Code the duty of the Director of Utilities is to promote and facilitate the maximum utilization of water and to discourage and prohibit the waste of water; and

WHEREAS, the following proposed irrigation standards promote efficient water use with regards to the most current industry standards for irrigation systems; and

WHEREAS, the implementation of these standards promotes water efficient outdoor water use with respect to the City's Conservation goals in the 2004 Water Management Plan; and

WHEREAS, these standards have been reviewed by local Green Industry professionals serving the City; and

WHEREAS, the purpose of these standards is to conserve water resources and promote the use of reclaimed water.

**NOW, THEREFORE, BE IT ORDAINED BY THE CITY COUNCIL OF THE CITY OF AURORA, COLORADO:**

Section 1. That section 138 of the city Code of Aurora, Colorado is hereby amended by adding a new section to be numbered 138-192, which shall read as follows:

#### **SEC. 138-192. IRRIGATION STANDARDS**

##### **A. PURPOSE.**

TO CONSERVE WATER RESOURCES AND PROMOTE THE USE OF RECLAIMED WATER SOURCES BY ESTABLISHING REQUIREMENTS FOR DESIGN, INSTALLATION AND MAINTENANCE OF AUTOMATIC IRRIGATION SYSTEMS.

##### **B. APPLICABILITY.**

THESE STANDARDS SHALL APPLY TO:

**(1) NEW DEVELOPMENT.**

ALL NEW DEVELOPMENT WHERE AUTOMATIC UNDERGROUND IRRIGATION OF LANDSCAPE AREAS IS REQUIRED PER CHAPTER 146, ARTICLE 14, (LANDSCAPING). INCLUDING ALL COMMON AREA LANDSCAPE TRACTS, TREE LAWNS, PRIVATE COMMON OPEN SPACE AND PRIVATE PARKS.

**(A) INDIVIDUAL RESIDENTIAL LOTS.**

THE INDIVIDUAL LOTS OF SINGLE-FAMILY DETACHED HOMES, TWO-FAMILY HOMES, AND SINGLE-FAMILY ATTACHED DUPLEX HOMES SHALL BE REQUIRED TO COMPLY ONLY WITH EQUIPMENT REQUIREMENTS AND THE FINAL CONSTRUCTION OBSERVATION REQUIREMENTS OF THIS SECTION.

**(2) REPLACEMENT OF EXISTING IRRIGATION SYSTEMS.**

EXISTING IRRIGATION SYSTEMS BEING REPLACED, MODIFIED OR EXPANDED PURSUANT TO CHAPTER 146.

EXISTING IRRIGATION SYSTEMS THAT ARE OPERATING IN AN EFFICIENT MANNER AND ARE NOT FOUND TO BE WASTING WATER AS FOUND IN SEC. 138-190 OF THE CITY OF AURORA CODE ARE EXEMPT FROM THESE STANDARDS WHEN PERFORMING ROUTINE MAINTENANCE, COMPONENT UP-GRADES, AND REPAIRS.

**C. LANDSCAPE PLANS.**

ALL LANDSCAPE PLANS REQUIRED BY CHAPTER 146 ZONING CODE, ARTICLE 14 LANDSCAPING SHALL CARRY A NOTATION REQUIRING COMPLIANCE WITH THESE STANDARDS.

**D. IRRIGATION DESIGN PLAN.**

PRIOR TO THE INSTALLATION OF THE IRRIGATION SYSTEM THE UTILITIES DEPARTMENT SHALL APPROVE A DESIGN PLAN PREPARED BY A DESIGNER THAT COMPLIES WITH THE SYSTEM REQUIREMENTS SPECIFIED IN THIS SECTION. AN ELECTRONIC DWG FILE IN AUTOCAD IS PREFERABLE. THE IRRIGATION DESIGN PLAN SHALL ACCURATELY AND CLEARLY IDENTIFY:

- PROPERTY BOUNDARIES
- LOCATIONS, MODEL AND SIZE OF ALL COMPONENTS OF THE IRRIGATION SYSTEM
- STATIC WATER PRESSURE AT THE POINT OF CONNECTION

- FLOW RATE, ZONE NUMBER, APPLICATION RATE (INCHES PER HOUR), AND DESIGN OPERATING PRESSURE FOR EACH ZONE OR STATION ON THE CONTROLLER
- BACKFLOW PREVENTER
- THE SQUARE FOOTAGE OF TURF AND PLANTING BEDS ON THE PLANS
- SITE WATER REQUIREMENTS

IRRIGATION DESIGNS FOR SITES WITH GREATER THAN 1 ½-INCH METERS MUST ALSO ACCURATELY AND CLEARLY IDENTIFY:

- PRESSURE LOSS WORKSHEET
- CALCULATION OF WATER USAGE IN GALLONS FOR THE YEAR
- IRRIGATION SCHEDULE

SUBMITTAL OF IRRIGATION PLANS SHALL BE CONCURRENT WITH THE SUBMITTAL OF CIVIL PLANS OR IF NO CIVIL PLANS ARE REQUIRED WITH APPLICATION FOR A BUILDING PERMIT.

THE DESIGN OF IRRIGATION SYSTEMS SHALL BE BASED ON APPROVED LANDSCAPE PLANS. AMENDMENTS TO LANDSCAPE PLANS SHALL REQUIRE AMENDMENTS TO THE IRRIGATION PLAN(S).

#### **E. DESIGNER QUALIFICATIONS.**

THE IRRIGATION DESIGNER SHALL BE A CERTIFIED IRRIGATION DESIGNER (COMMERCIAL) AS REGULATED BY THE IRRIGATION ASSOCIATION, OR A PERSON WITH A MINIMUM OF FIVE YEARS OF DEMONSTRATED EXPERIENCE DESIGNING IRRIGATION SYSTEMS. THE DESIGNER SHALL UPON REQUEST PRODUCE EVIDENCE OF THEIR EXPERIENCE THAT MAY INCLUDE REFERENCES, LETTERS OF RECOMMENDATION, PORTFOLIO OF WORK, PHOTOGRAPHS, AND EMPLOYMENT RECORDS. BY DEMONSTRATED EXPERIENCE PERSONS SHALL SUBSTANTIATE HAVING DESIGNED A MINIMUM OF THREE PROJECTS OF COMPARABLE SIZE AND COMPLEXITY.

#### **F. SYSTEM REQUIREMENTS.**

##### **(1) FLOW REQUIREMENT.**

THE SYSTEM SHALL BE DESIGNED SO IT IS CAPABLE OF PROVIDING SUFFICIENT WATER FOR ADEQUATE PLANT GROWTH DURING PERIODS OF PEAK DEMAND WHEN EVAPO-TRANSPIRATION (ET) IS HIGHEST. PEAK DEMAND SHALL BE BASED ON 1.8 INCHES PER WEEK FOR TURF AND 1.0 INCH PER WEEK FOR PLANTING BEDS. WATER REQUIREMENTS FOR EACH SITE MUST BE DETERMINED PRIOR TO DESIGNING THE SYSTEM IN ORDER TO SIZE THE SYSTEM FOR ADEQUATE CAPACITY.

**(2) RUN TIMES.**

WATERING SHALL OCCUR IN ACCORDANCE WITH THE AURORA UTILITIES WATER MANAGEMENT PLAN APPROVED BY CITY COUNCIL.

**(3) PRESSURE CONTROL.**

IN ORDER TO CONTROL PRESSURE AND PROTECT THE SYSTEM FROM DAMAGE, PRESSURE-REDUCING VALVES AND/OR MASTER VALVES SHALL BE LOCATED IMMEDIATELY DOWNSTREAM OF THE BACKFLOW PREVENTER IF STATIC PRESSURE IS 15 PSI ABOVE THE SYSTEM DESIGN PRESSURE. SYSTEM DESIGN PRESSURE IS THE REQUIRED OPERATING PRESSURE AT THE HEAD PLUS TOTAL SYSTEM PRESSURE LOSSES, INCLUDING TAP, SERVICE AND METER.

PRESSURE AT ALL HEADS SHALL BE WITHIN 10 PERCENT OF THE SYSTEM DESIGN OPERATING PRESSURE. (EXAMPLE: A HEAD DESIGNED FOR 30.0 PSI SHALL OPERATE WITHIN THE 27.0 TO 33.0 PSI RANGE.) THIS SHALL BE ACCOMPLISHED BY USING PRESSURE-REDUCING VALVES (NOT FLOW CONTROL VALVES OR FLOW RESTRICTION DEVICES) INSTALLED UNDER OR IN THE BASE/STEM OF THE HEAD. A COMBINATION PRESSURE-REDUCING & CONTROL VALVE CAN BE USED TO CONTROL THE PRESSURE WITHIN A ZONE.

**(4) SPRINKLER HEAD LAYOUT.**

HEAD SPACING SHALL NOT EXCEED 50 PERCENT OF THE DIAMETER OF EACH HEAD'S EFFECTIVE COVERAGE. PART CIRCLE HEADS MUST BE USED AROUND THE ENTIRE TURF/BED PERIMETER TO AVOID OVERTHROW ONTO BUILDINGS, ASPHALT, CONCRETE, ETC., AND WALKS WITH PLANTING ON ONE SIDE ONLY. WALKS OF FIVE FEET OR LESS WITH PLANTING ON EACH SIDE MAY BE SPRAYED OVER.

RADIUS REDUCTION AT THE HEAD SHALL NOT EXCEED 25 PERCENT OF THE DESIGNED MAXIMUM ARC AS INDICATED IN MANUFACTURERS' CATALOG AND ON THE PLANS. IF THERE ARE COVERAGE PROBLEMS IN UNIQUE AREAS, USE PART CIRCLE "BACKUP HEADS" WHERE THERE IS NOT ENOUGH SPACE FOR ANOTHER ROW OF FULL CIRCLE HEADS.

**(A) SLOPES IN EXCESS OF A 3-TO-1 RATIO.**

HEADS PLACED AT THE BOTTOM OF A SLOPE NEED TO BE VALVED SEPARATELY. MID-POINT ON THE SLOPE SHALL NEED A MODERATE AMOUNT OF WATER AND THEREFORE THESE HEADS SHALL ALSO HAVE THEIR OWN ZONE. HEADS PLACED ON THE TOP OF THE SLOPE MUST BE VALVED SEPARATELY, AS THEY SHALL WATER FOR THE LONGEST PERIOD OF TIME BECAUSE THIS SECTION WILL HAVE NO

RUN-OFF FROM ABOVE AND IS EXPOSED TO MORE SUN AND WIND.

LATERAL LINES AND HEADS ON SLOPES SHALL BE INSTALLED ALONG THE CONTOUR RATHER THAN UP AND DOWN THE SLOPES.

(B) NARROW STRIPS, PARKING LOT ISLANDS, TREE LAWNS, AND MEDIANS.

IF THE AREA IS LESS THAN 15 FEET WIDE USE POP-UP SPRAY HEADS WITH A NOZZLE RADIUS THAT WILL NOT EXCEED THE WIDTH OF THE STRIP. THE INSTALLATION OF SUBSURFACE DRIP IRRIGATION SYSTEMS IN THESE AREAS IS ENCOURAGED.

(C) ZONE CONTROL.

IRRIGATED AREAS SHALL BE DIVIDED INTO ZONES THAT HAVE THE SAME WATER REQUIREMENTS.

THE DESIGNER SHALL IDENTIFY ALL DEPRESSIONS, DRAINAGE WAYS, AND STORM WATER DETENTION, RETENTION, AND WATER QUALITY PONDS, AND ZONE THEM SEPARATELY FROM ADJACENT HIGHER AREAS. HEADS AND VALVES SHALL BE INSTALLED ADJACENT TO AND OUTSIDE OF THESE LOW AREAS.

ALL HEADS WITHIN A ZONE MUST HAVE MATCHED APPLICATION RATES. HEADS THAT HAVE DIFFERENT APPLICATION RATES SHALL BE ZONED SEPARATELY. PARKING LOT MEDIANS AND ISLANDS THAT ARE SURROUNDED BY PAVEMENT SHALL BE LOCATED IN SEPARATE ZONES FROM OTHER LANDSCAPE AREAS.

## **(5) HYDRAULICS.**

(A) PRESSURE LOSS TABLE.

A PRESSURE LOSS TABLE SHALL BE INCLUDED ON THE IRRIGATION PLAN. THE TABLE SHALL INCLUDE INFORMATION FOR ZONES WITH THE HIGHEST FLOW RATE THAT ARE LOCATED THE GREATEST DISTANCE FROM THE SOURCE. USE 70 PERCENT OF THE MAXIMUM SAFE WATER FLOW WHEN CALCULATING PRESSURE LOSSES FOR ALL



IRRIGATION SYSTEMS. THE TABLE SHALL INCLUDE THE FOLLOWING INFORMATION:

- VALVE NUMBER AND FLOW RATE
- AVAILABLE STATIC WATER PRESSURE
- LOSS OR GAIN DUE TO ELEVATION
- DETAILED LIST OF VARIOUS COMPONENT PRESSURE LOSSES & VELOCITIES
- THE OPERATING PRESSURE REQUIREMENTS
- PROJECT LOCATION AND DATE
- WATER SERVICE & METER

THE FOLLOWING TABLE SHALL BE USE WHEN CALCULATING PRESSURE LOSSES FOR METERS AND COPPER PIPE:

Average Flow & Pressure Losses for Displacement Type Meters & "K" Copper Pipe

Size in.	Maximum <u>Capacity</u> Flow Criteria		70% of Max		K Copper (C=130) <u>Service Line Loss</u>	
	GPM	PSI loss	GPM	PSI	PSI/100'	PSI/50'
¾"	30	7.3	21	5.11	59.7	29.9
1"	50	6.7	35	4.69	41.2	20.6
1-1/2"	100	7.3	70	5.11	21.5	10.7
2"	160	8.6	112	6.02	13.2	6.6
3"	300	9.3	210	6.51	6.1	3.1

(B) TAP SIZING.

REQUIRED MINIMUM METER SIZE IS BASED ON THE TOTAL IRRIGATED TURF AREA AS PROVIDED IN TABLE A AND TABLE B.

TABLE A. REQUIRED MINIMUM METER SIZE.

TURF AREA IN SQUARE FEET	METER SIZE
UP TO 35,000	¾"
UP TO 60,000	1"
UP TO 120,000	1.5"
UP TO 190,000	2"
UP TO 360,000	3"

SHRUB BEDS ARE NOT INCLUDED IN THE ABOVE SIZING CALCULATIONS BECAUSE THEY ARE USUALLY IRRIGATED BY LOW VOLUME SUBSURFACE DRIP SYSTEMS. IF THE SHRUB BED AREA IS MORE THAN 15% OF THE TURF AREA, A LARGER TAP MAY BE NECESSARY.

TABLE B. REQUIRED MINIMUM METER SIZE FOR LARGE OPEN SPACES WITH ROTOR HEADS & WATER USE @ 20".

TURF AREA SQUARE FEET	METER SIZE
UP TO 140,000	1.5"
UP TO 220,000	2"
UP TO 440,000	3"

**(C) BACKFLOW PREVENTER & SPECIALTY VALVES.**

MAXIMUM VELOCITY FOR WATER FLOW THROUGH BACKFLOW PREVENTERS SHALL NOT EXCEED 7.5 FPS.

WHEN USING PRESSURE-REDUCING VALVES, THE SIZING OF THE BACKFLOW PREVENTER AND SPECIALTY VALVE SHALL BE BASED ON THE DEVICES FLOW CAPACITY AT THE REDUCED PRESSURE LEVEL.

**(6) SIZING.**

MAINLINE VELOCITIES SHALL NOT EXCEED 5 FPS. LATERAL LINE VELOCITIES SHALL NOT EXCEED 6 FPS.

**(7) PRESSURE DIFFERENCE.**

PRESSURE DIFFERENCE BETWEEN ANY TWO HEADS IN THE ZONE SHALL NOT EXCEED 10 PERCENT OF THE HIGHEST PRESSURE WITHIN THE ZONE.

**(8) EQUIPMENT SELECTION.**

**(A) SPRAY HEADS.**

POP-UP SPRAY HEADS FOR TURF AREAS SHALL HAVE A MINIMUM POP-UP HEIGHT OF FOUR INCHES. A SIX-INCH POP-UP HEIGHT SHALL BE USED ADJACENT TO STREETS. THE 12" POP-UP HEIGHT SHALL BE USED IN GROUND COVER AND FLOWERBEDS. HEADS SHALL SEAL IN THE OPERATING POSITION AT 10 PSI OR LESS, AND THE WATER USED IN THE FLUSH MODE SHALL NOT EXCEED .05 GPM. HEADS SHALL

HAVE A RATCHETING FEATURE FOR ADJUSTING THE DIRECTION OF SPRAY.

POP-UP SPRAY HEADS SHALL HAVE BUILT IN CHECK VALVES AND A PRESSURE-REGULATING DEVICE (SET AT 30 PSI) INSTALLED IN THE BASE OF THE STEM, A CHECK VALVE INSTALLED IN THE BASE OF THE BODY, AND UNDER SLOTTED PLASTIC NOZZLES, WITH MATCHED PRECIPITATION RATE NOZZLES.

(B) ROTARY HEADS.

ROTARY HEADS SHALL BE INTERNALLY DRIVEN, HAVE A CLOSED-CASE ROTOR WITH WIPER SEALS THAT IS SPRING RETRACTED. THE POP-UP STEM SURFACE DIAMETER SHALL BE LESS THAN 2 INCHES, AND HAVE A MINIMUM POP-UP HEIGHT OF 4-INCHES. ALL HEADS SHALL HAVE CHECK VALVES BUILT INTO THE BOTTOM OF THE BODY. SMALL RADIUS ROTOR HEADS SHALL BE USED FOR AREAS THAT RANGE FROM 20 FEET TO 30 FEET WIDE.

(C) AUTOMATIC RAIN SHUT-OFF DEVICES.

ALL SYSTEMS SHALL BE EQUIPPED WITH AN AUTOMATIC RAIN SHUT-OFF DEVICE.

(D) AUTOMATIC CONTROLLERS.

THE FOLLOWING FEATURES SHALL BE INCORPORATED INTO THE CONTROLLER:

- MULTIPLE PROGRAMS/START TIMES
- WATER BUDGETING AND/OR SPRAY AND SOAK FEATURES
- MEMORY RETENTION
- BATTERY BACKUP
- FLEXIBLE DAY PROGRAMMING FOR ANY INTERVALS

(E) DRIP IRRIGATION.

DRIP IRRIGATION IS DEFINED AS SUBSURFACE LOW VOLUME SYSTEMS THAT APPLY WATER IN GALLONS PER HOUR (GPH) THROUGH EITHER CALIBRATED PRESSURE COMPENSATING EMITTERS, BUBBLERS, MICO-SPRAYS, AND/OR MICRO-SPRAY POP-UPS DIRECTLY TO A PLANT'S ROOT SYSTEM OR TO A PLANTED AREA.

SELF-FLUSHING, PRESSURE-COMPENSATING SUBSURFACE DRIP IRRIGATION IS RECOMMENDED IN ALL PLANTING BEDS THAT ARE MULCHED OR IN NARROW TURF STRIPS WHERE SPRAY HEADS ARE NOT PRACTICAL. ALL SUBSURFACE DRIP SHALL BE INSTALLED IN THE SOIL, NOT ON THE SURFACE.

AS WITH SPRINKLER IRRIGATION, DRIP IRRIGATION SHALL BE ZONED FOR VARYING PLANT NEEDS, SLOPES, AND EXPOSURES.

(F) BACKFLOW PREVENTION DEVICES.

ALL IRRIGATION SYSTEMS SHALL BE EQUIPED WITH AN APPROPRIATE BACKFLOW PREVENTION DEVICE.

**(9) PERFORMANCE STANDARDS FOR WATER USES.**

EACH UNDERGROUND AUTOMATIC IRRIGATION SYSTEM SHALL BE DESIGNED TO DELIVER A MAXIMUM BUDGET OF 28-INCHES (17.46 GALLONS) OF WATER PER SQUARE FOOT OF TURF AND 15 INCHES (9.35 GALLONS) OF WATER PER SQUARE FOOT OF PLANT BED PER GROWING SEASON. NATURAL PRECIPITATION IS NOT INCLUDED IN THIS TOTAL.

TOTAL GALLONS BUDGETED PER ONE THOUSAND SQUARE FEET OF TURF FOR ONE GROWING SEASON MAY BE CALCULATED AS:

$$1000 \text{ X } 28'' \text{ X } 0.623 \text{ GAL/INCH} = 17,444 \text{ GALLONS PER GROWING SEASON.}$$

TOTAL GALLONS BUDGETED PER ONE THOUSAND SQUARE FEET OF PLANT BED PER GROWING SEASON MAY BE CALCULATED AS:

$$1,000 \text{ X } 15'' \text{ X } 0.623 \text{ GAL/INCH} = 9,345 \text{ GALLONS PER GROWING SEASON.}$$

TABLE C SHOWS THE ANNUAL BUDGETED WATER IN GALLONS FOR ALL TURF AREAS AND PLANT BEDS. THE COMPLETED TABLE SHALL BE SHOWN ON THE IRRIGATION PLAN.

TABLE C. CALCULATED ANNUAL IRRIGATION WATER USE

AREA IN TURF (SF)	AREA IN TURF X 28 IN. X 0.623 = GALLONS APPLIED	AREA IN PLANT BEDS (SF)	AREA IN PLANT BEDS X 15 IN. X 0.623 = GALLONS APPLIED

TOTAL ANNUAL GALLONS APPLIED TURF + PLANT BEDS	_____ TOTAL ANNUAL GALLONS
---	----------------------------

**(10) IRRIGATION SCHEDULE.**

AN ANNUAL IRRIGATION PROGRAM WITH MONTHLY IRRIGATION SCHEDULES SHALL BE SHOWN ON THE IRRIGATION PLANS. THE IRRIGATION SCHEDULE SHALL SHOW THE FOLLOWING INFORMATION:

- RUNTIME
- NUMBER OF CYCLES PER DAY
- FREQUENCY OF IRRIGATION FOR EACH ZONE.

THE IRRIGATION SYSTEM OPERATOR SHALL MONITOR AND ADJUST AUTOMATIC SPRINKLERS BASED ON THE CURRENT MONTH AND AVAILABLE MOISTURE. INFORMATION ON EFFICIENT WATERING SHALL BE AVAILABLE FROM THE UTILITIES DEPARTMENT OFFICE OF WATER CONSERVATION.

**(11) FINAL CONSTRUCTION OBSERVATION.**

ALL FEES FOR IRRIGATION METERS MUST BE PAID IN FULL AT TIME OF SYSTEM CONSTRUCTION.

PRIOR TO ISSUANCE OF A PERMANENT CERTIFICATE OF OCCUPANCY THE IRRIGATION SYSTEM MUST BE INSPECTED BY THE UTILITIES DEPARTMENT.

PRIOR TO INSPECTION, THE SITE MUST BE FREE OF CONSTRUCTION DEBRIS SO THAT COMPONENTS OF THE SYSTEM CAN BE OBSERVED. CONTACT INFORMATION FOR THE IRRIGATION SYSTEM INSTALLER MUST ALSO BE PROVIDED. OPERATING MANUALS AND A RECOMMENDED WATERING SCHEDULE MUST BE AVAILABLE.

**(12) MAINTENANCE AND OPERATION REQUIREMENTS.**

A SEASONAL MAINTENANCE SCHEDULE BEGINNING ON APRIL 1 THROUGH OCTOBER 1 SHALL BE SHOWN ON THE IRRIGATION PLAN TO ESTABLISH PROCEDURES FOR OPTIMUM IRRIGATION EFFICIENCY AND PREVENTIVE MAINTENANCE PRACTICES THAT WILL CONSERVE WATER RESOURCES. THE MAINTENANCE SCHEDULE SHOULD INCLUDE THE FOLLOWING ITEMS:

- CHECK HEADS FOR COVERAGE & LEAKAGE
- REPROGRAM CONTROLLERS MONTHLY OR MORE OFTEN IF NECESSARY ACCORDING TO THE SEASONAL NEEDS
- VERIFY THAT THE WATER SUPPLY AND PRESSURE ARE AS STATED IN THE DESIGN
- INSPECT THE BACKFLOW PREVENTION DEVICE TO DETERMINE IF IT IS WORKING CORRECTLY
- PERIODICALLY VERIFY THAT SENSORS IN THE IRRIGATION SYSTEM ARE WORKING PROPERLY

**(13) LANDSCAPE IRRIGATION AUDITS.**

IT IS RECOMMENDED THAT THE OPERATORS OF ALL IRRIGATION SYSTEMS EXCEPT AS PROVIDED IN SECTION B, APPLICABILITY, SHALL PERFORM A LANDSCAPE IRRIGATION AUDIT EVERY 5 YEARS.

AUDITS MAY BE REQUIRED WHENEVER IT IS DETERMINED BY THE DIRECTOR OF UTILITIES OR HIS/HER DESIGNEE THAT ANY OF THE FOLLOWING CONDITIONS APPLY:

- VIOLATIONS FOR WASTING WATER.
- REPORTED OR SUSPECTED NON-COMPLIANCE WITH THESE STANDARDS.

**G. REQUIREMENTS FOR RECLAIMED DOMESTIC WASTEWATER.**

ALL IRRIGATION SYSTEMS INSTALLED ON A SITE MUST CONNECT TO THE RECLAIMED WATER SYSTEM WHERE RECLAIMED DOMESTIC WASTEWATER IS AVAILABLE MEETING THE REQUIREMENTS OF THE COLORADO DEPARTMENT OF HEALTH AND ENVIRONMENT (CDPHE), “RECLAIMED DOMESTIC WASTEWATER CONTROL REGULATIONS” AND THE FOLLOWING GUIDELINES.

**(1) DESIGN REQUIREMENTS.**

DESIGN REQUIREMENTS FOR IRRIGATION SYSTEMS THAT WILL CONNECT TO RECLAIMED DOMESTIC WASTEWATER SHALL MEET THE FOLLOWING CRITERIA:

**(A) SITE WATER CONTAINMENT**

RECLAIMED DOMESTIC WASTEWATER SHALL BE CONFINED TO THE AUTHORIZED USE AREA, STRICTLY MINIMIZING RUNOFF AND/OR PONDING OF THE WATER. ZONE SLOPES AND MICROCLIMATES TO STRICTLY MINIMIZE RUNOFF

AND/OR PONDING OF RECLAIMED DOMESTIC WASTEWATER. DIRECT AND WINDBLOWN IRRIGATION WATER SPRAY SHALL BE CONFINED TO THE SITE. PRECAUTIONS SHALL BE TAKEN TO ENSURE THAT RECLAIMED DOMESTIC WASTEWATER WILL NOT BE SPRAYED ON ANY FACILITY OR AREA NOT DESIGNATED FOR APPLICATION.

(B) PIPE MARKING.

IDENTIFICATION SHALL BE ONE OF THE FOLLOWING:

- THE WARNING “CAUTION: RECLAIMED WATER - DO NOT DRINK” EMBOSSED OR STENCILED ON THE PIPE AT 5-FOOT INTERVALS.
- PURPLE PLASTIC MARKING TAPE THE WIDTH OF THE PIPE WITH THE WARNING “CAUTION: RECLAIMED WATER - DO NOT DRINK”, AND TAPED TO THE PIPE EVERY 10-FEET.
- INSTALL PURPLE-COLORED PIPE.

(C) OUTLETS.

ALL SPRINKLER HEADS, QUICK COUPLER VALVES, AND OTHER OUTLETS SHALL HAVE PURPLE-COLORED TOPS OR RUBBER COVERS. PERMANENT HOSE OUTLETS ARE NOT ALLOWED.

(D) VALVE BOXES.

ALL VALVE BOXES USED IN THE IRRIGATION SYSTEM SHALL HAVE PURPLE-COLORED VALVE BOX LIDS.

(E) IRRIGATION CONTROLLERS.

IRRIGATION CONTROLLERS SHALL BE LABELED INSIDE AND OUT WITH “CAUTION: RECLAIMED WATER - DO NOT DRINK”. A LAMINATED REDUCED DRAWING OF THE IRRIGATION SYSTEM SHALL BE KEPT IN THE CONTROLLER CABINET.

(F) BACKFLOW PREVENTION.

AN APPROVED REDUCED-PRESSURE PRINCIPLE BACKFLOW PREVENTION DEVICE OR AN AIR GAP SHALL BE PROVIDED AT ALL POTABLE WATER SERVICE CONNECTIONS TO RECLAIMED DOMESTIC WASTEWATER USE AREAS.

(G) WARNING SIGNS.

NOTIFICATION BY CLEARLY VISIBLE SIGNS SHALL BE PROVIDED TO INFORM THE PUBLIC THAT RECLAIMED DOMESTIC WASTEWATER IS BEING USED FOR IRRIGATION AND IS NOT SAFE FOR DRINKING. THE NOTIFICATION SHALL INCLUDE POSTING OF SIGNS OF SUFFICIENT SIZE TO BE CLEARLY READ IN ALL APPLICATION AREAS AND AROUND IMPOUNDMENTS WITH THE FOLLOWING WORDING:  
ATTENTION: RECLAIMED DOMESTIC WASTEWATER - DO NOT DRINK

SIGNS SHOULD BE IN THE PREDOMINANT LANGUAGE(S) SPOKEN IN THE AREA AT THE SITE.

THESE REQUIREMENTS ARE BASED ON COLORADO DEPARTMENT OF PUBLIC HEALTH AND ENVIRONMENT REGULATION 84, RECLAIMED DOMESTIC WASTEWATER CONTROL REGULATION AND AMERICAN WATER WORKS ASSOCIATION MANUAL M24, DUAL WATER SYSTEMS.

**H. ENFORCEMENT AND PENALTY.**

ANY VIOLATION OF THIS SECTION SHALL BE CONSIDERED A WASTE OF WATER AS DEFINED IN SEC. 138-190 AND THE ENFORCEMENT PROVISIONS OF SEC. 138-190 SHALL APPLY.

UPON THE ISSUANCE OF ANY VIOLATION THE SYSTEM SHALL BE ADJUSTED WITHIN THREE DAYS OF NOTIFICATION FOR COMMERCIAL PROPERTIES AND WITHIN 7 DAYS OF NOTIFICATION FOR RESIDENTIAL PROPERTIES WHENEVER IRRIGATION WATER FALLS OR RUNS ONTO HARD SURFACES SUCH AS SIDEWALKS, STREETS OR DRIVEWAYS. BREAKDOWNS OR FAILURES OF THE IRRIGATION SYSTEM SHALL BE REPAIRED WITHIN THREE DAYS OF NOTIFICATION FOR COMMERCIAL PROPERTIES AND WITHIN 7 DAYS OF NOTIFICATION FOR RESIDENTIAL PROPERTIES TO AVOID UNNECESSARY WASTING OF WATER. ANY OBSERVED OR REPORTED WASTING OF WATER MAY RESULT IN PENALTIES AS DESCRIBED BY SEC.138-190 OF THE CITY OF AURORA CODE.

Section 2. That all ordinances or parts of ordinances of the city Code of the City of Aurora, Colorado, in conflict herewith are expressly repealed.

Section 3. That, pursuant to Section 5-5 of the Charter of the City of Aurora, Colorado, the second publication of this ordinance shall be by reference, utilizing the ordinance title.